

HONDA COMMON SERVICE MANUAL

**This manual is provided at no charge, and may be distributed
freely.**

Pages were scanned from photocopies, as Honda no longer print originals.
The alphabeticised index is not available.

***COMMON SERV
MANUAL***

OWNERS MANUAL

PART NO. 61CM000C

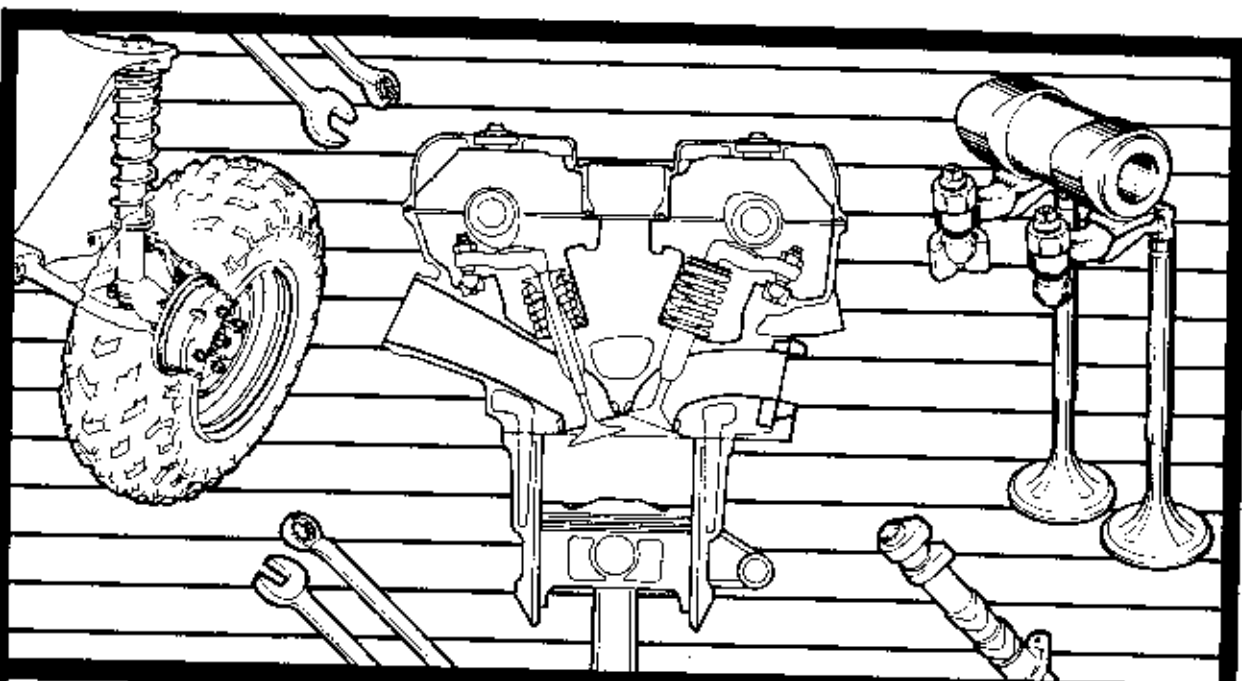

HONDA

Common Service Manual

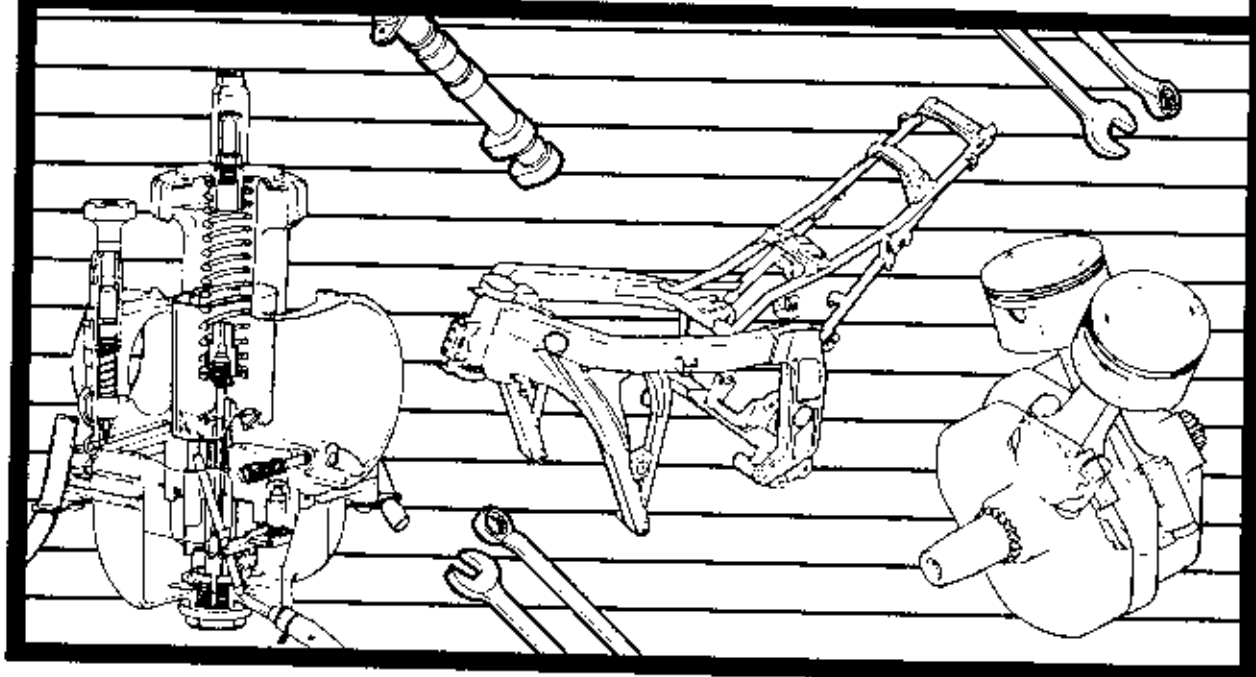

© HONDA MOTOR CO., LTD. 1988
PRINTED IN JAPAN

61CM000
B1508811

IMPORTANT SAFETY NOTICE

⚠ WARNING Indicates a strong possibility of severe personal injury or death if instructions are not followed.

CAUTION: Indicates a possibility of equipment damage if instructions are not followed.

NOTE: Gives helpful information.

Detailed descriptions of standard workshop procedures, safety principles and service operations are not included. It is important to note that this manual contains *some* warnings and cautions against some specific service methods which could cause **PERSONAL INJURY** to service personnel or could damage a vehicle or render it unsafe. Please understand that those warnings could not cover all conceivable ways in which service, whether or not recommended by Honda, might be done or of the possibly hazardous consequences of each conceivable way, nor could Honda investigate all such ways. Anyone using service procedures or tools, whether or not recommended by Honda, *must satisfy himself thoroughly* that neither personal safety nor vehicle safety will be jeopardized by the service methods or tools selected.

HOW TO USE THIS MANUAL

This manual explains the theory of operation of the various systems common to HONDA motorcycles and motor scooters and ATVs. It also provides basic information on troubleshooting, inspection and repair of components and systems found on these machines.

Refer to the Model Specific Service Manual for the model you are servicing for adjustments, maintenance and repair information for components on that model.

Section 1 provides general information on the whole motorcycle as well as Warnings and Cautions to remember when performing maintenance and repairs.

Sections 2 through 15 cover all aspects of the engine and drive train.

Sections 16 through 20 include all of the component groups that make up the chassis.

Section 21 through 25 apply to the various electrical components and systems found on Honda motorcycles.

An extensive alphabetized Index provides rapid access to information on specific components or systems.

All information, illustrations, directions and specifications included in this publication are based on the latest product information available at the time of approval for printing. Honda Motor Co., LTD. reserves the right to make changes at any time without notice and without incurring any obligation whatever. No part of this publication may be reproduced without written permission.

HONDA MOTOR CO., LTD.
Service Publications Office













Date of Issue: Sep., 1988
© HONDA MOTOR CO., LTD.

CONTENTS

	GENERAL INFORMATION	1	
	MAINTENANCE	2	
ENGINE AND DRIVE TRAIN	ENGINE TESTING	3	
	LUBRICATION	4	
	COOLING SYSTEM	5	
	EXHAUST SYSTEM	6	
	EMISSION CONTROL SYSTEMS	7	
	FUEL SYSTEM	8	
	CYLINDER HEAD/VALVES	9	
	CYLINDER/PISTON	10	
	CLUTCH	11	
	V-MATIC BELT DRIVE SYSTEM	12	
	TRANSMISSION/GEARSHIFT LINKAGE	13	
	CRANKCASE/CRANKSHAFT	14	
	FINAL DRIVE/OUTPUT SHAFT	15	
	CHASSIS	WHEELS/TIRES	16
		BRAKES	17
FRONT SUSPENSION/STEERING		18	
REAR SUSPENSION		19	
FRAME/BODY PANELS		20	
ELECTRICAL	ELECTRICAL FUNDAMENTALS	21	
	BATTERIES/CHARGING/LIGHTING SYSTEM	22	
	IGNITION SYSTEMS	23	
	ELECTRIC STARTER/STARTER CLUTCH	24	
	LIGHTS/METERS/SWITCHES	25	

Symbol Marks

These symbols used throughout this manual show specific service procedures. If supplementary information is required pertaining to these symbols, it would be explained specifically in the text without the use of the symbols.

	Use recommended engine oil, unless otherwise specified.
	Use molybdenum solution (mixture of the engine oil and molybdenum grease with the ratio 1 : 1).
	Use multi-purpose grease (Lithium based multi-purpose grease NLGI #2 or equivalent)
	Use molybdenum disulfide grease (containing more than 3% molybdenum disulfide, NLGI #2 or equivalent) Example: Molykote® BR-2 plus manufactured by Dow Corning, U.S.A. Multi-purpose M-2 manufactured by Mitsubishi Oil Japan
	Use molybdenum disulfide paste (containing more than 40% molybdenum disulfide, NLGI #2 or equivalent) Example: Molykote® G-n Paste manufactured by Dow Corning, U.S.A. Honda Moly 45 (U.S.A. only) Rocol ASP manufactured by Rocol Limited, U.K. Rocol Paste manufactured by Sumico Lubricant, Japan
	Use silicone grease
	Apply locking agent. Use the agent of the middle strength, unless otherwise specified.
	Apply sealant
	Replace the part(s) with new one(s) before assembly.
	Use brake fluid, DOT 3 or DOT 4. Use the recommended brake fluid, unless otherwise specified.
	Use Automatic Transmission Fluid (ATF).
	Use special tool
	Use optional tool. These tools are obtained as you order parts.

Abbreviations

Following abbreviations may be used in this manual. They stand for:

Assy	Assembly
R	Right (Right side viewed from rear side)
L	Left (Left side viewed from rear side)
IN	Intake side/Inside
EX	Exhaust side/Exterior side
STD	Standard
OP	Optional
OS	Oversized
L (100L)	Number of links (100 links)
C2	Countershaft 2nd gear (Number indicates the stage of gear)
M5	Mainshaft 5th gear (Number indicates the stage of gear)
rpm	Rotating speed per minute
BTDC	Before Top Dead Center
ATDC	After Top Dead Center
BBDC	Before Bottom Dead Center
ABDC	After Bottom Dead Center
AC	Alternating current
DC	Direct current
CDI	Capacitive discharge ignition
4P	Number of coupler pins

Following letters or marks stamped on the parts indicate the installation direction.

IN	Install with "IN" toward inside/exhaust side.
TOP	Install with "TOP" toward up. (Do not install with the letter upside down.)
UP	Install with the "UP" toward up. (Do not install with the letter upside down.)
UP Δ	Install with the triangular mark toward up. (Some parts might be stamped with an arrow.)
F →	Install with the arrow toward front. (Some parts might be stamped with a triangular mark.)
R (RH)	Install on the right side, viewed from rear side. If an arrow or triangular mark is stamped, install with the mark toward right.
L (LH)	Install on the left side, viewed from rear side. If an arrow or triangular mark is stamped, install with the mark toward left.
F (FR)	Indicates the front side of the vehicle.
R (RR)	Indicates the rear side of the vehicle.
OUT (OUTSIDE)	Install with the letter toward out.
LOWER	Indicates lower level.
UPPER (FULL)	Indicates upper level.
←	Indicates the rotating direction, if stamped on the rotating part.

If a punch mark (•) is stamped on a part, it indicates the installation direction or alignment point. Pay attention to the mark when assembling.

1. GENERAL INFORMATION

GENERAL SAFETY	1-1	FASTENERS	1-6
SERVICE RULES	1-3	BALL BEARING REPLACEMENT	1-14

GENERAL SAFETY

Carbon Monoxide

If the engine must be running to do some work, make sure the area is well ventilated. Never run the engine in an enclosed area.

▲WARNING

- The exhaust contains poisonous carbon monoxide gas that can cause loss of consciousness and may lead to death.

Run the engine in an open area or with an exhaust evacuation system in an enclosed area.

Gasoline

Work in a well ventilated area. Keep cigarettes, flames or sparks away from the work area or where gasoline is stored.

▲WARNING

- Gasoline is extremely flammable and is explosive under certain conditions. **KEEP OUT OF REACH OF CHILDREN.**

Battery Hydrogen Gas & Electrolyte

▲WARNING

- The battery gives off explosive gases; keep sparks, flames and cigarettes away. Provide adequate ventilation when charging.
- The battery contains sulfuric acid (electrolyte). Contact with skin or eyes may cause severe burns. Wear protective clothing and a face shield.
 - If electrolyte gets on your skin, flush with water.
 - If electrolyte gets in your eyes, flush with water for at least 15 minutes and call a physician.
- Electrolyte is poisonous.
 - If swallowed, drink large quantities of water or milk and follow with milk of magnesia or vegetable oil and call a physician. **KEEP OUT OF REACH OF CHILDREN.**

Coolant

Under some conditions, the ethylene glycol in engine coolant is combustible and its flame is not visible. If the ethylene glycol does ignite, you will not see any flame, but you can be burned.

▲WARNING

- Avoid spilling engine coolant on the exhaust system or engine parts. They may be hot enough to cause the coolant to ignite and burn without a visible flame.
- Coolant (ethylene glycol) can cause some skin irritation and is poisonous if swallowed. **KEEP OUT OF REACH OF CHILDREN.**
- Do not remove the radiator cap when the engine is hot. The coolant is under pressure and could scald you.
- Keep hands and clothing away from the cooling fan, as it starts automatically.

If it contacts your skin, wash the affected areas immediately with soap and water. If it contacts your eyes, flush them thoroughly with fresh water and get immediate medical attention. If it is swallowed, the victim must be forced to vomit then rinse mouth and throat with fresh water before obtaining medical attention. Because of these dangers, always store coolant in a safe place, away from the reach of children.

Brake Fluid

CAUTION

- Spilling fluid on painted, plastic or rubber parts will damage them. Place a clean shop towel over these parts whenever the system is serviced. **KEEP OUT OF REACH OF CHILDREN.**

Brake Dust

Never use an air hose or dry brush to clean brake assemblies. Use an OSHA-approved vacuum cleaner or alternate method approved by OSHA, designed to minimize the hazard caused by airborne asbestos fibers.

▲WARNING

- Inhaled asbestos fibers have been found to cause respiratory disease and cancer.

GENERAL INFORMATION

Nitrogen Pressure

For shock absorbers with a gas-filled reservoir:

⚠ WARNING

- Use only nitrogen to pressurize the shock absorber. The use of an unstable gas can cause a fire or explosion resulting in serious injury.
- The shock absorber contains nitrogen under high pressure. Allowing fire or heat near the shock absorber could lead to an explosion that could result in serious injury.
- Failure to release the pressure from a shock absorber before disposing of it may lead to a possible explosion and serious injury if it is heated or pierced.

To prevent the possibility of an explosion, release the nitrogen by pressing the valve core. Then remove the valve stem from the shock absorber reservoir. Dispose of the oil in a manner acceptable to the Environment Protection Agency (EPA).

Before disposal of the shock absorber, release the nitrogen by pressing the valve core. Then remove the valve stem from the shock absorber.

Hot Components

⚠ WARNING

- Engine and exhaust system parts become very hot and remain hot for some time after the engine is run. Wear insulated gloves or wait until the engine and exhaust system have cooled before handling these parts.

Used Engine/Transmission Oil

⚠ WARNING

- Used engine oil (or transmission oil in two-strokes) may cause skin cancer if repeatedly left in contact with the skin for prolonged periods. Although this is unlikely unless you handle used oil on a daily basis, it is still advisable to thoroughly wash your hands with soap and water as soon as possible after handling used oil. **KEEP OUT OF REACH OF CHILDREN.**

SERVICE RULES

Use only metric tools when servicing this motorcycle or scooter. Metric bolts, nuts and screws are not interchangeable with English fasteners. The use of incorrect tools and fasteners may damage the motorcycle or scooter.

Special tools are designed to remove or replace a specific part or assemblies without damage. The use of other procedures, without using the specified special tools, may damage the parts.

Clean the outside of a part or assembly before removing it from the motorcycle or opening its cover for service. Dirt which has accumulated on the outside could fall into the engine, chassis or brake system and cause damage later.

Clean the parts after disassembly but before measuring them for wear. Parts should be washed in high-flash point solvent and dried with compressed air. Beware of parts containing O-rings or oil seals since these are adversely affected by most cleaning solvents.

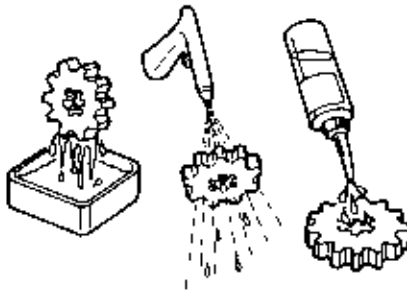

Control cables must not be bent or distorted. This will lead to stiff operation and premature cable failure.

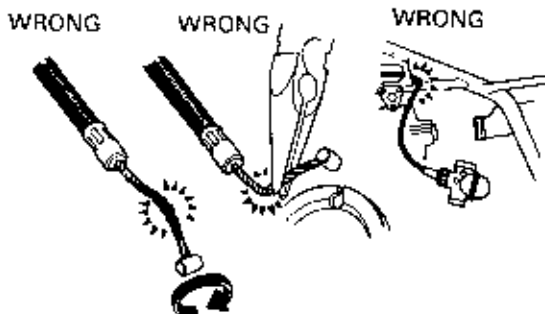

Rubber parts can deteriorate with age and are highly-susceptible to damage from solvents and oils. Check these parts before reassembly and replace as necessary.

Loosening a part with multiple fasteners should be done from the outside-to-inside in a crisscross pattern, loosening the small fasteners first. Loosening the big fasteners first will place an excessive force on the smaller fasteners.

Complex assemblies, such as transmission parts, should be stored in the proper assembly order and held securely with wire. This will simplify reassembly at a later date.

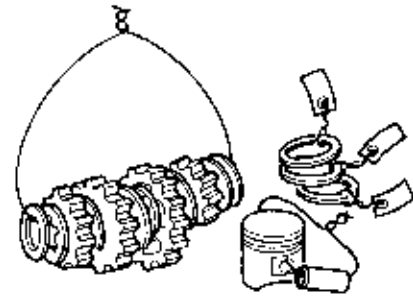

Reassembly position of critical parts should be noted before the parts are disassembled. This will allow those dimensions (depth, distance, or position) to be correctly duplicated upon reassembly.

Non-reuseable parts are always replaced whenever something is disassembled. These include the gaskets, metal sealing washers, O-rings, oil seals, snap rings, and cotter pins.



CAUTION

- Coolant or brake fluid will damage the appearance of painted parts. In addition, these fluids can damage the structural integrity of plastic or rubber parts.

GENERAL INFORMATION

Ball bearings are removed using tools which apply force against one or both inner and outer bearing races. If the force is applied against only one race (either inner or outer), the bearing will be damaged during removal and must be replaced. If the force is applied against both races equally, the bearing will not be damaged during removal.

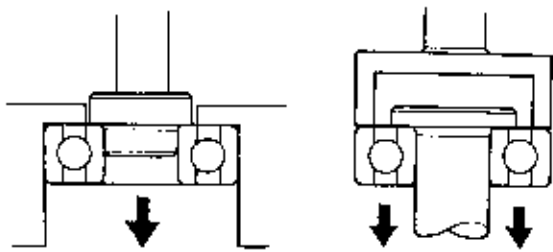

Both examples ruin the bearing

Ball bearings are cleaned in high flash-point solvent then dried with compressed air. Air dry the bearing while holding both races to prevent it from spinning. If the bearing is allowed to spin, the high speed generated by the air jet can overspeed the bearing and cause permanent damage.

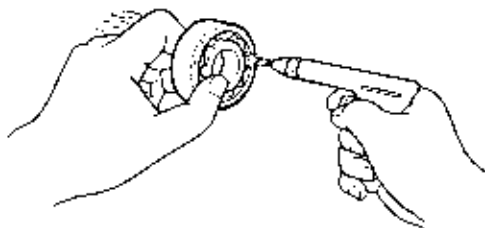

Ball bearings are checked (after cleaning) by slowly rotating the inner race while holding the outer race stationary. If any radial play or roughness is felt, it must be replaced. The bearing should have no axial play; if it has noticeable axial play, it must be replaced.

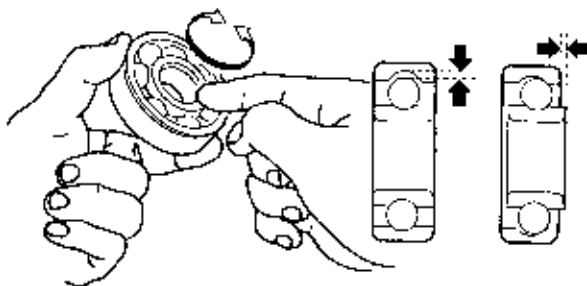

Ball bearings are always installed with the manufacturer's name and size code facing out. (Facing out meaning—the name and sizing code should be visible from the side the bearing is installed from.) This is true for open, single-sealed and double-sealed bearings. Apply the proper grease to open and single sealed bearings before reassembly.

SINGLE-SEALED
TYPE



DOUBLE-SEALED
TYPE



OPEN
TYPE

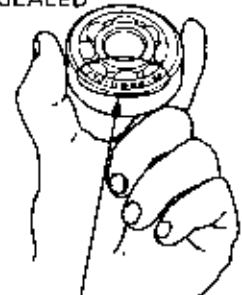

MANUFACTURER'S
NAME, BEARING No.

Snap rings are always installed with the chamfered (rolled) edge facing away from the thrust of the mating part. This way, pressure against the snap ring presses against the areas in the snap ring groove with the most parallel contact area against one another. Installed incorrectly, pressure against the rolled or chamfered edge could compress the snap ring with the possibility of dislodging it. Never reuse snap rings since they are often used to control end play and become worn with normal use. Wear is especially critical on snap rings which retain spinning parts such as gears. After installing a snap ring, always rotate it in its groove to be sure it is fully-seated.

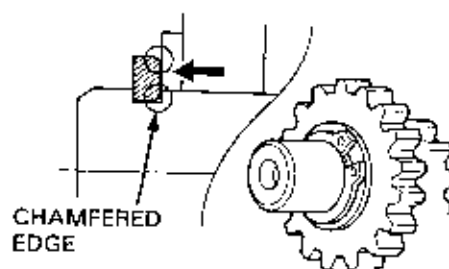

CHAMFERED
EDGE

Grease or oil sliding or turning parts with the recommended lubricant before reassembly.

Replacement parts and fluids must be genuine Honda or recommended by Honda. The use of non-Honda parts and non recommended fluids can have an adverse affect on performance and durability.

Reassembly operation should be tested, whenever possible, before the part is installed onto the motorcycle.

Bolt or screw lengths can vary for an assembly, cover, or case. These different lengths must be installed into the correct locations. If you become confused, place the bolts into their holes and compare the exposed lengths; each should be exposed by the same amount.

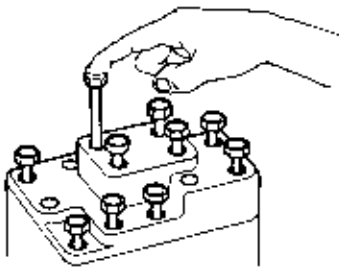

Torquing multiple sized fasteners should be done as follows: tighten all to hand-tight, then torque big fasteners before little fasteners. Torque pattern should be crisscross from inner-to-outer. To minimize distortion, critical fasteners should be torqued in two or three increments. Unless specified otherwise, bolts and fasteners are installed clean and dry; do not use oil on the threads.

Oil seals are always installed with grease packed into the seal cavity and the manufacturer's name facing the outside (dry side). When installing seals, always check that the shaft over which the seal fits is smooth and free of burrs which could damage the seal.

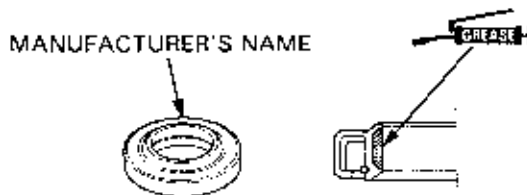

Old gasket material or sealant must be removed before reassembly. If the gasket surface is damaged slightly, it may be possible to smooth that area with an oil stone.

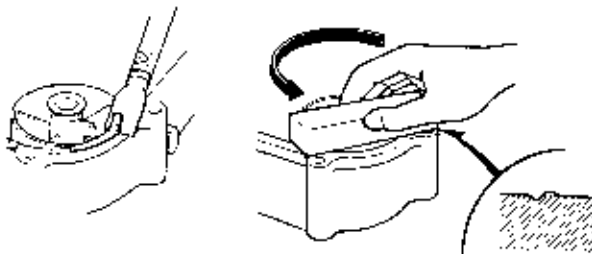

Rubber hoses (fuel, vacuum, or coolant) should be installed so the end is bottomed onto its fitting. This allows adequate area for the hose clip to grip the hose beneath the flared end of the fitting.

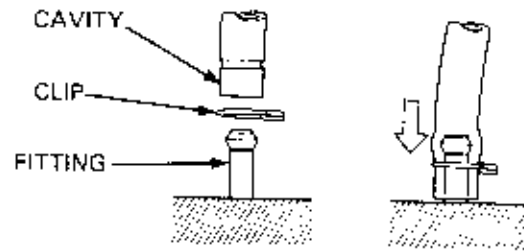

Rubber or Plastic Dust/Dirt Boots should be replaced securely in the exact positions they were designed for.

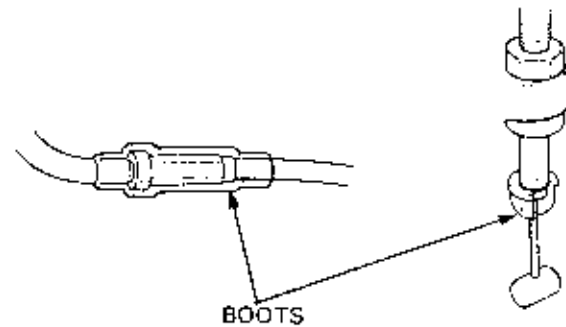

GENERAL INFORMATION

FASTENERS

A motorcycle is composed of a number of connected parts. A variety of fasteners are used to connect these parts. Unlike permanent connection methods like welding, riveting and glueing, threaded fasteners are essential as a means of non-permanent connection which can be disconnected whenever necessary.

Roughly estimated, the thread diameter is the O.D. of the male thread or the I.D. across the full width of the "valleys" of the female thread.

The pitch is the thread-to-thread distance that a male/female bolt moves in a turn.

TYPES OF THREADS

Metric threads, as specified by the International Standards Organization (ISO), are used on HONDA motorcycles.

The typical ISO threads found on Honda products are the following threads and pitches.

Diameter (mm)	Pitch (mm)	Diameter (mm)	Pitch (mm)
3	0.5	12	1.25
4	0.7	14	1.5
5	0.8	16	1.5
6	1.0	18	1.5
8	1.25	20	1.5
10	1.25		

The few parts which do not have conventional (ISO) metric threads are listed below.

The threads are NOT INTERCHANGEABLE with conventional (ISO) metric threads.

Description	* Symbols (typical examples)	Example of application
Parallel threads for tubes	PF 1/8	Oil pressure switch
Tapered threads for tubes	PT 1/8	Thermostatic units
Thread type used on bicycles	BC 3.2	Spokes and nipples
Spark plug threads	M 12S	Spark plugs
Automobile tire Valve stem	TV8	Tire valve stem

* The figures given above represent screw sizes. An example is given for each type of screw or thread type.

THREAD SIZES

Thread sizes are represented by male thread diameters. Widths across flats represent applicable tool sizes. Note that these widths are not related to thread sizes.

On Honda motorcycles, scooters and ATVs, the size of the bolt, nut or screw is considered to be the thread diameter.

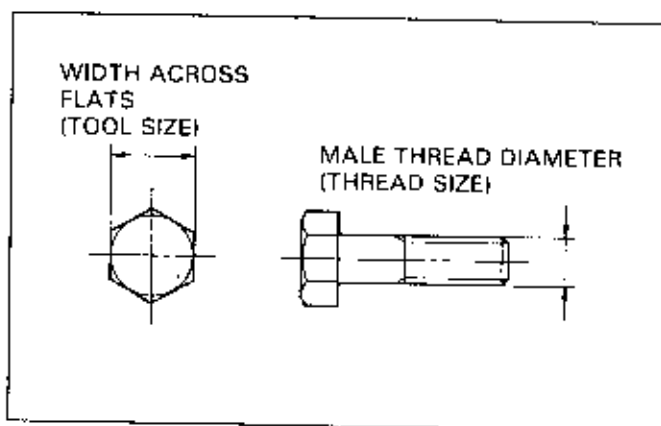
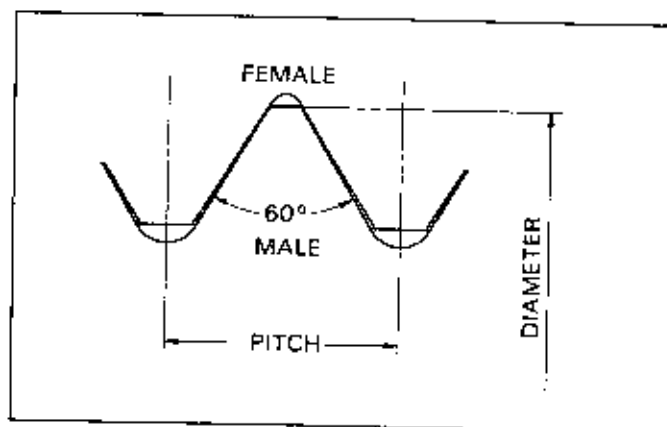

WIDTH ACROSS FLATS

The width across flats is the portion where tools such as a wrench or a socket are applied. Applicable tool sizes are represented by these widths. The denomination of a "10 mm wrench," for example, represents a wrench to be used on hex-heads with widths across flats of 10 mm.

On the right is a table to show representative widths across flats and thread sizes often used for Honda motorcycles. Not all widths across the flats are shown.

Some other common widths across the flats are 22, 24, 27, 30, 32 mm, etc. Spark plugs have particular width across flats; they should be removed with special spark plug wrenches (16, 18 and 20.6 mm).

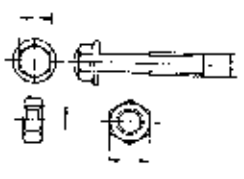
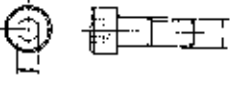
Hexagon portion	Width across flats	Thread (diameter) x (pitch)
	8	5 x 0.8
	8	6 x 1.0
	10	6 x 1.0
	12	8 x 1.25
	14	10 x 1.25
	17	12 x 1.25
	19	14 x 1.5
	5	6 x 1.0
	6	8 x 1.25
	8	10 x 1.25
	10	12 x 1.25

HEX-HEAD BOLT STRENGTH MARKINGS

Strength marks, indicating material type, are visible on the head of some hex-headed bolts. Bolts are classified into standard bolts and high-tension bolts by material types. During assembly, take care not to install any high-tension bolts in the wrong place. Note that while standard bolts are tightened to a standard torque unless otherwise specified, high-tension bolts always have their own specified torque values. 6 mm SH bolts without strength marks (small-headed flange bolts with a width across flats of 8 mm and a thread size of 6 mm) are all considered standard bolts.

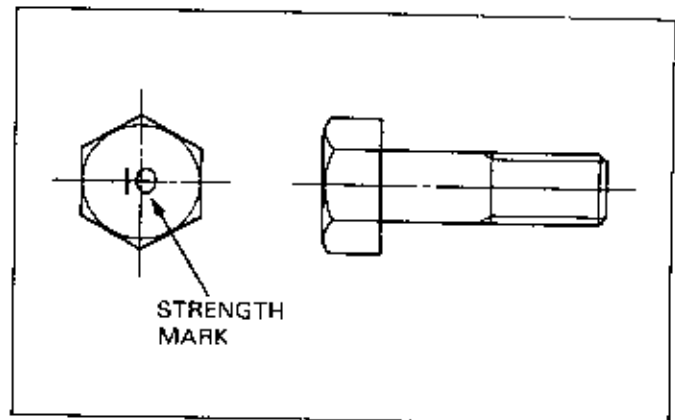

Mark	No mark	⊖ or ⊕	10	12
Strength Class.	5.8	8.8	10.9	12.9
Tension strength Class.	50-70 kg/mm ²	80-100 kg/mm ²	100-120 kg/mm ²	120-140 kg/mm ²
	Standard Bolts		High tension	

DR-type (or dished-headed) bolts, without strength markings (flange bolts with hex-heads and weight reduction holes in them), are classified by outer flange diameters. Be careful about the installation points and the torques of high-tension bolts having the same hexagon dimensions as standard bolts, but having larger flanges.

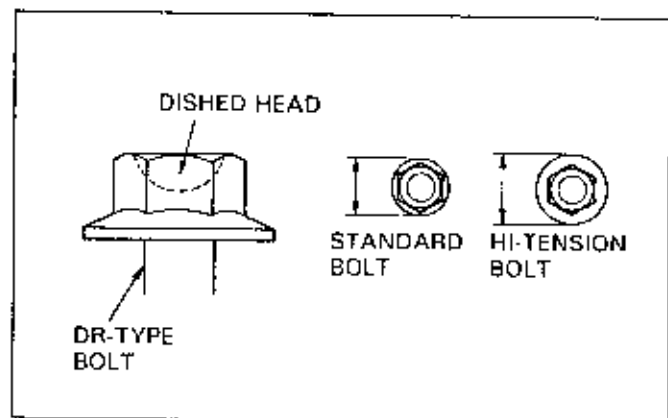

GENERAL INFORMATION

UBS bolts are in the high-tension category. They can be recognized by undercuts under their bolt necks. UBS bolts are marked either with or without strength marks. Furthermore, these bolts are so structured so they will not easily loosen, by the provision of a slight slope of 5 to 60° on the bottom of the flange.

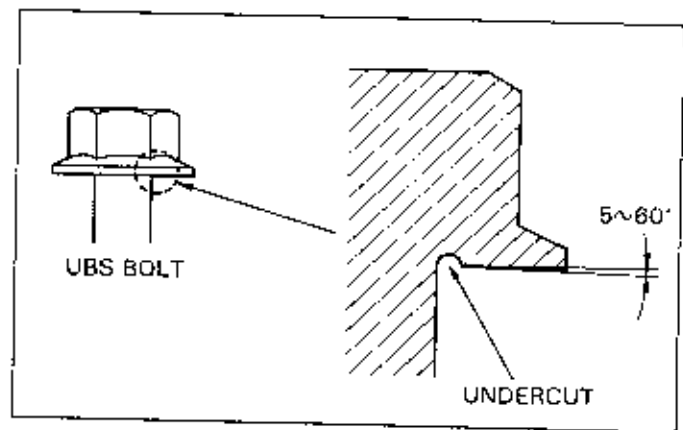

TORQUE VALUES (Tightening Force)

When two or more parts are connected by a fastener, their connection should not be affected by external forces; i.e. there should be no gap between the parts which are fastened together. The first priority of threaded fastener connected parts is the state of being tightened with a sufficient force. When any tightening force is sufficient for the intended function, it is called "proper tightening force".

The tightening force of one bolt is equal to bolt axial tensile strength. Bolt tightening force is, therefore, often called "bolt axial force".

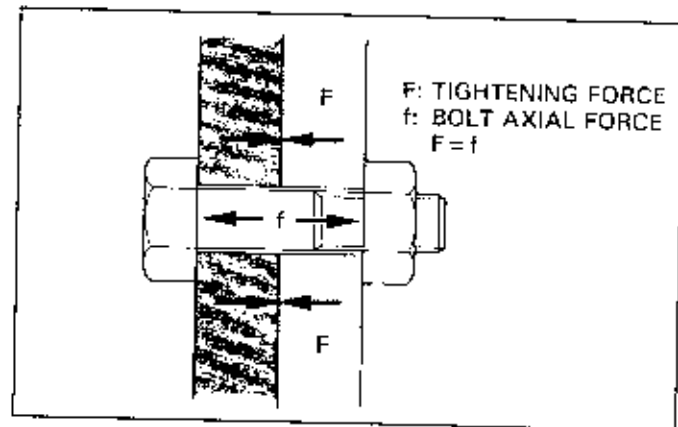

A decrease in tightening force (initial tightening force) due to the passage of time, external forces or vibration applied during use is called "fastener loosening". Even when the initial tightening force was correct, loosening may cause it to decrease in later use, finally damaging some parts. As a countermeasure against fastener loosening, retightening is carried out after a certain period of time. Periodically tightening wheel spokes is an example of this operation.

Proper tightening forces are specified according to fastener strength, strength of fastened parts and intensity of external forces. Tightening must be carried out in strict accordance with this specification, especially at important points. Tightening a connecting rod bearing cap with a stronger force than is proper, for example, will deform the tightened part (bearing cap) slightly and cause the oil clearance for the bearing to become smaller than specified, which may lead to the bearing seizing. An insufficient tightening force, on the other hand, may allow the nuts or bearing caps to loosen and fall off during engine operation, leading to serious engine trouble.

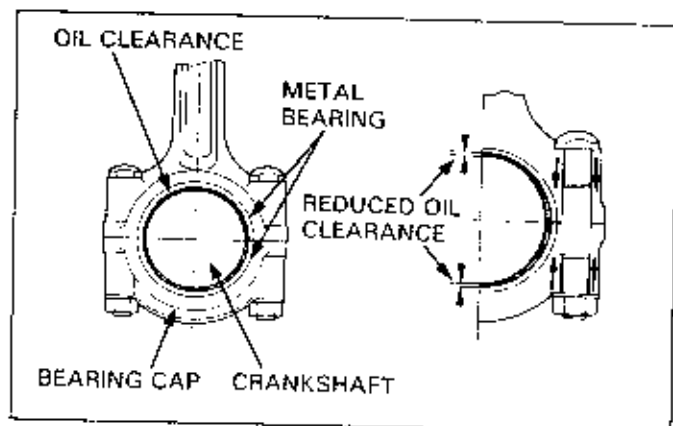

As mentioned earlier, the most important point in fastener tightening is the tightening force. The problem is that this tightening force (axial tension) is difficult to measure. Using a predetermined tightening torque is, therefore, the most common method of controlling fastener tension.

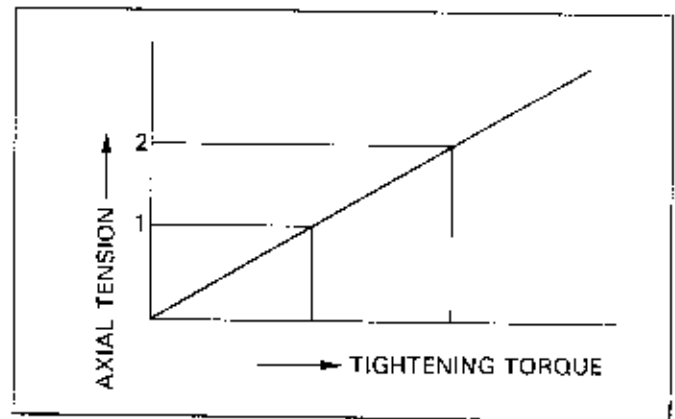

It must be noted that, in this control method using torque values, the axial tension is proportional to the torque under certain conditions. Under other conditions, this important axial tension varies even when the fastener is tightened to the same torque.

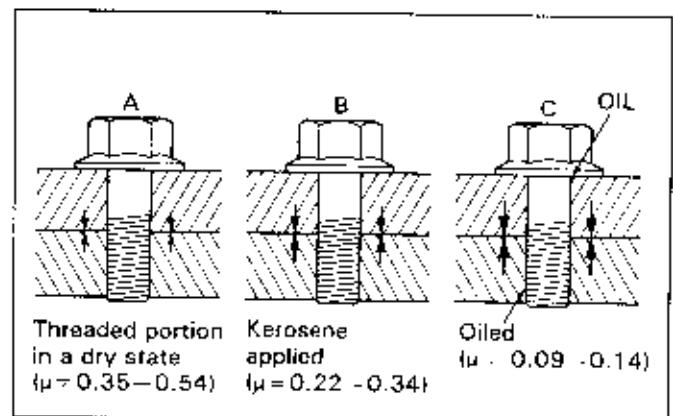

The table on the right gives some examples of friction coefficient when oil has adhered to the threaded portion. Under the same conditions from the viewpoint of the tightening torque and the material of the parts that are fastened together, $\langle \mu \rangle$ varies largely. Out of the tightening torque applied on an unlubricated fastener, 88 to 92 percent is consumed by the friction of flanges and thread surfaces and only 8 to 12 percent is effectively transformed into axial tension. This percentage of transformation into an axial tension increases as the above-mentioned friction decreases; i.e. as the value $\langle \mu \rangle$ decreases, the axial tension increases. Axial tension varies when the same tightening torque value is obtained. Furthermore, in a dry (unlubricated) state, the value $\langle \mu \rangle$ varies in a wider range and has a tendency to increase as the tightening/loosening procedure is repeated.

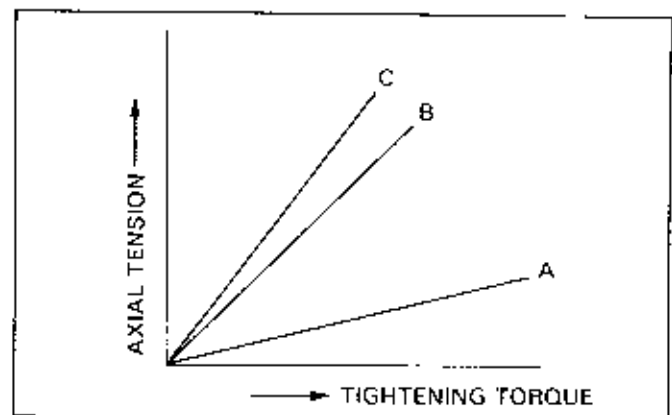

It is important to oil the threads of specific fasteners when instructed to do so in the Model Specific manual. Oiling the threads of these fasteners ensures stable fastening tension in critical areas. No other bolts besides those specifically pointed out in the Model Specific service manual text require oil on their threads.

Lubrication of the threaded portion or of the bottom of the flange reduces friction and the anti-loosening effect. However, this lubrication also increases fastener axial tension and results in a sufficient tightening strength, so that the fastener is less likely to loosen.

GENERAL INFORMATION

Torque values are determined according to fastener size and strength, and the strength of the parts that are fastened together. In many of our previous service manuals, torque values are specified within a certain range. Due to slight variation in torque wrench precision and fastener friction coefficient, the target torque value should be the middle of the range of the torque value specified. The Model Specific manuals provide only the simplified, middle-range torque values. Kg-m is used as a tightening torque unit.

Example: A torque of 1 kg-m refers to the moment of force obtained when a 1-meter long wrench is loaded with 1 kilogram. At the same moment, a heavier load is needed as the effective wrench length is shorter.

1 kg-m = 10 N·m

1 kg-m = 7 ft-lb

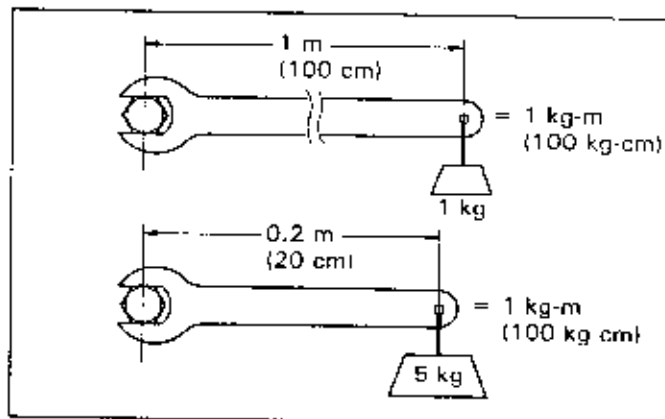

FASTENER LOOSENING

In most of the cases, fastener loosening is due to external forces repeatedly applied to, or working against, the fastener (such as vibration), thus reducing screw axial tension.

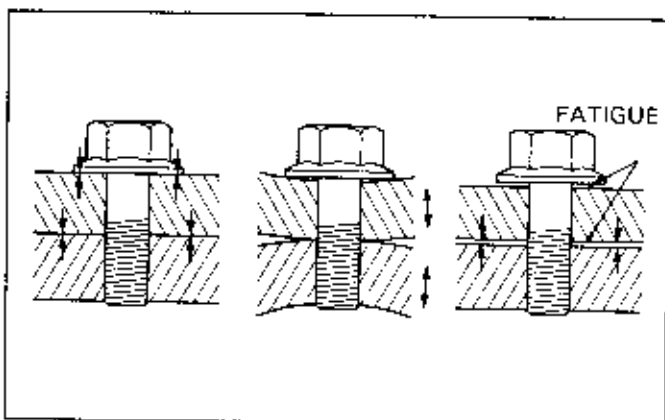

Certain areas of the motorcycle or scooter are subject to repeated and severe external forces. Special bolts with a high percentage of elastic deformation capability are used in these areas.

Installing common bolts in these areas with special requirements may lead to loosening or shearing of the fastener. Therefore it is important to identify both these specially designed bolts and the positions where these are required.

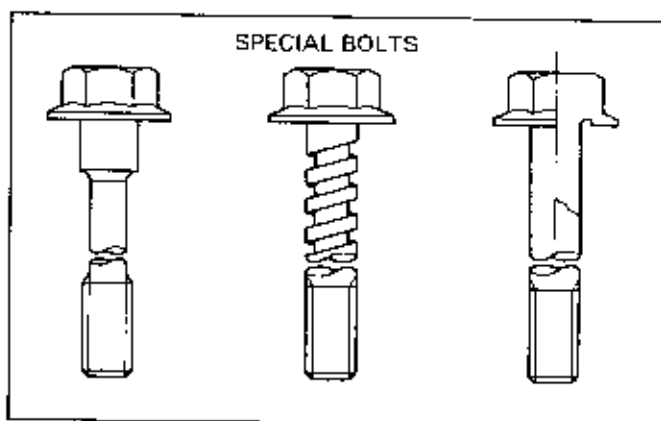

Always clean fasteners thoroughly if there is any dirt present anywhere on the fastener.



Installing fasteners with dirt or other foreign matter on their threads or on the bolt or nut bearing surfaces will result in improper axial tension, despite the use of the proper torque specification.

As the dirt or foreign matter breaks down due to vibration and the attached parts working against each other, the fastener will soon work its way loose.

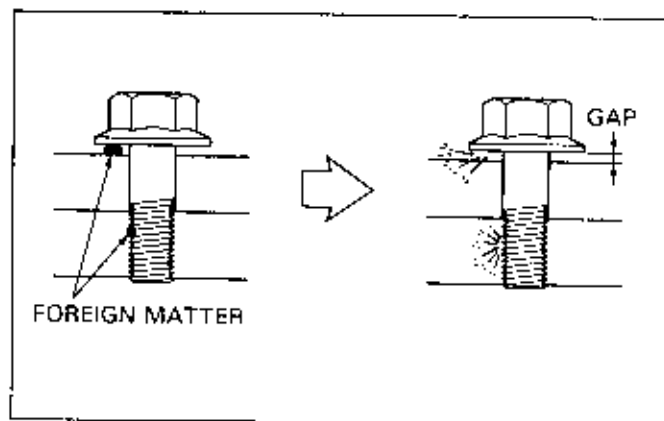

There are several methods of preventing the various types of fasteners from loosening. Some representative examples are presented on the next page, together with the necessary instructions for proper use.

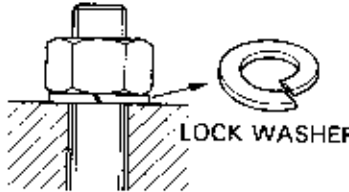
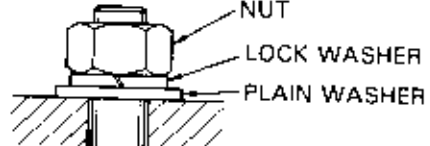
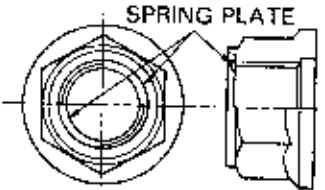
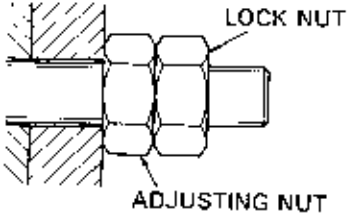
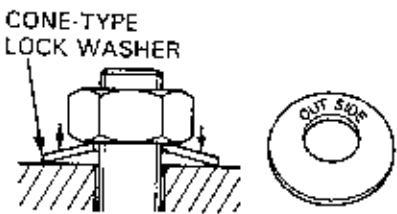

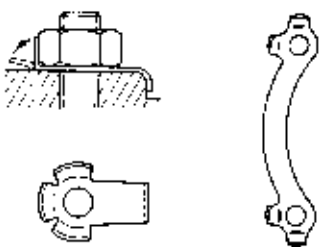
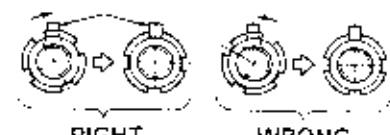
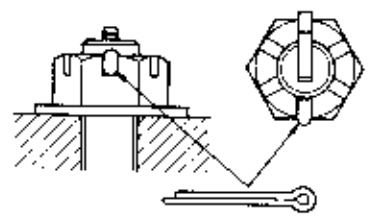
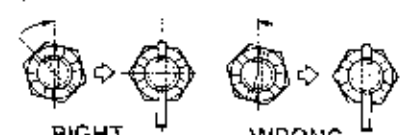

Locking

TYPES OF FASTENERS	APPLICATIONS	CAUTION
<p>1. Lock washer (Conventional split-ring type)</p>  <p>LOCK WASHER</p> <p>When the washer is compressed under the bearing surface pressure, the elasticity of the spring and the edges of the ring ends prevent loosening.</p>	<ul style="list-style-type: none"> • Various points on frame (Bolts-incorporating washers are also available.) 	<ul style="list-style-type: none"> • Do not use lock washers which have lost their elasticity or are deformed or eccentric. • Excessive torque will open or deform the washer and render it useless. • Use an appropriate size for thread dia. or hex. point. • When using with a plain washer, always put the lock washer between the nut and plain washer.  <p>NUT LOCK WASHER PLAIN WASHER</p>
<p>2. Self-locking nut</p>  <p>SPRING PLATE</p> <p>This is a nut with a spring plate on top. This spring plate presses against the thread, making it difficult for the nut to loosen. After removal, this type of nut can be used again.</p>	<ul style="list-style-type: none"> • Important points on the frame <ul style="list-style-type: none"> – PRO-Link pivot point nuts – Axle nuts 	<ul style="list-style-type: none"> • Avoid using spring plate nuts with deformed or damaged spring plates. • The bolt head must be held during nut installation and removal due to the resistance of the nut spring plate against the bolt. • If the bolt length is too short, the spring plate portion of the lock nut will not engage with the thread fully.
<p>3. Double nut</p>  <p>LOCK NUT ADJUSTING NUT</p> <p>The lock nut, applied to the adjusting nut from outside, presses against the latter thus preventing loosening.</p>	<ul style="list-style-type: none"> • Chain adjusters • Cable adjusters (Also used for removing or installing the stud bolts) 	<ul style="list-style-type: none"> • Hold the adjusting nut securely and tighten the lock nut. • Any attempt to loosen both nuts (adjusting and lock nuts) simultaneously will damage the bolt threads.
<p>4. Cone spring lock washer</p>  <p>CONE-TYPE LOCK WASHER</p> <p>The bearing surface presses on the cone spring washer and the spring reaction presses against the nut to prevent it from loosening.</p>	<ul style="list-style-type: none"> • Important points inside the engine <ul style="list-style-type: none"> – Clutch lock nut – Primary gear lock nut • Drive sprocket center bolt 	<ul style="list-style-type: none"> • Installing in the opposite direction prevents effective locking. Always install cone washers with their "OUTSIDE" mark facing out. No marked, set cone spring washers as shown in the table at left. • Do not use if damaged or deformed. • When using a lock nut chamfered on one side, install the nut with chamfered side facing the lock washer as shown below.  <p>LOCK NUT CHAMFERED EDGE</p>

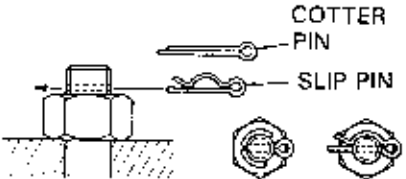
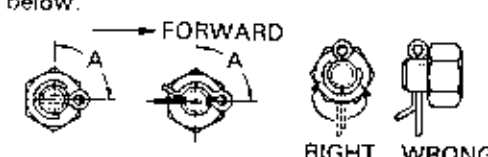
GENERAL INFORMATION

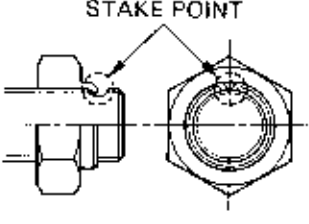
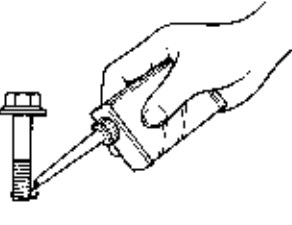
TYPES OF FASTENERS	APPLICATIONS	CAUTION
<p>5. Tongued lock plate</p>  <p>Bend the tongue (claw) to the flat face of nut or into the groove of the nut to lock the nut or bolt head.</p>	<ul style="list-style-type: none"> • Important points inside engine <ul style="list-style-type: none"> – Clutch lock nut • Important safety points on the frame <ul style="list-style-type: none"> – Steering head bearing top nut – Driven sprocket nuts 	<ul style="list-style-type: none"> • Ensure that a tongue (claw) has locked the nut properly. • Since repeated bending/straightening damages the tongue, replace the lock plate with a new one whenever the lock plate is removed. • Align the tongue to the nut in such a manner that the nut aligns perfectly when proper nut torque is reached, or so that the nut must be tightened further to align the tongue. • Do not align the nut in a position where the locking tongue aligns, but the nut torque is less than specified.  <p style="text-align: center;">RIGHT WRONG</p>
<p>6. Castle-headed nut</p>  <p>Inserting a cotter pin through a nut and bolt prevents loosening.</p>	<ul style="list-style-type: none"> • Important safety points on the frame <ul style="list-style-type: none"> – Axle nut – Brake torque rod 	<ul style="list-style-type: none"> • Since repeated bending/straightening damages cotter pins, always use new cotter pins during assembly. • Tighten the nut to the specified torque. Then align the next possible pin hole while tightening the nut just beyond the specified torque. • Do not align the holes in a position where the nut torque is less than the specified torque.  <p style="text-align: center;">RIGHT WRONG</p> <ul style="list-style-type: none"> • Bend the cotter pin as shown below.  <p style="text-align: center;">RIGHT WRONG</p>
<p>7. Slip pin/cotter pin</p>  <p>Inserting a slip pin or cotter pin through a bolt prevents the nut from loosening.</p>	<ul style="list-style-type: none"> • Frame important safety points <ul style="list-style-type: none"> – Brake rod 	<ul style="list-style-type: none"> • Since repeated bending /straightening damages cotter pins, always use new cotter pins during assembly. Although slip pins can be used again, replace slip pins with new ones if they are deformed or fatigued. • When using a cotter pin or slip pin on suspension and wheel components, install the pin with the head facing forward. If installed in the opposite direction, these pins may be bent and eventually broken and knocked out due to hitting stationary objects or from thrown stones on off-road bikes. Be sure to bend cotter pins properly as shown below.  <p style="text-align: center;">RIGHT WRONG</p> <ul style="list-style-type: none"> • Set the pin head in any position within the range A shown above.

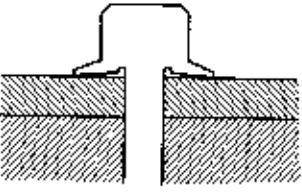
TYPES OF FASTENERS	APPLICATIONS	CAUTION
<p>8. Stake-type lock nut</p>  <p>Stake (or indent) the collar of the nut to make it match the groove in the shaft.</p>	<ul style="list-style-type: none"> • Important points inside the engine <ul style="list-style-type: none"> – Clutch center lock nut • Wheel bearing retainer • Shift drum stopper plate 	<ul style="list-style-type: none"> • During disassembly, eliminate the staking point to loosen the nut. • Replace the nut, if the old staked area of the nut aligns with the groove of the shaft after tightening the nut to specified torque. • After tightening the nut to the specified torque, stake the nut collar by striking it with a drift punch in such a way that the staking point matches the shaft groove. Ensure that the staking point has entered into the groove at least 2/3 of the groove depth.
<p>9. Thread locking agent</p>  <p>Apply a thread locking agent to the thread to prevent loosening.</p>	<ul style="list-style-type: none"> • Rotating points inside the engine, points which if loosened, may contact rotating parts. <ul style="list-style-type: none"> – Stator coil bolt – Bearing retainer bolts – Shift drum stopper plate bolt • Frame <ul style="list-style-type: none"> – Fork socket bolts – Brake disc bolts 	<ul style="list-style-type: none"> • Application of a locking agent increases loosening torque. Take care not to damage the bolt during removal. • Before applying a locking agent clean off all oil and/or residual adhesive remaining on the threads and dry them completely. • Application of an excessive amount of adhesive may, during loosening, damage the thread or cause the bolt to be broken. Applying a small amount of adhesive to the end of the bolt threads distributes the adhesive throughout when the bolt is threaded in. <p style="text-align: center;">APPLY LOCKING AGENT</p> 
<p>10. UBS bolt</p>  <p>The threads are pressed by the reaction on the inclined bolt flange.</p>	<ul style="list-style-type: none"> • Used on the critical areas of the engine/frame where a nut cannot be used to tighten. <p>Engine;</p> <ul style="list-style-type: none"> – cylinder – cylinder head <p>Frame;</p> <ul style="list-style-type: none"> – foot peg – bracket 	<ul style="list-style-type: none"> • The tightening surface where the bolt flange seats should be level and smooth.

BALL BEARING REPLACEMENT

Removing Ball Bearings

Ball bearings are removed using tools which apply force against one or both (inner and outer) races. If the force is applied against only one race (either inner or outer), the bearing will be damaged during removal and must be replaced. If the force is applied against both races (equally), the bearing can be reused.

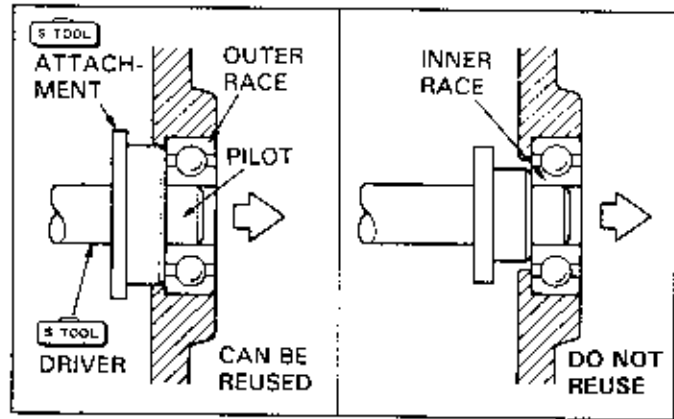

If the bearing is in a blind hole in the crankcase and cannot be removed by hammering on the opposite side, remove it with a bearing remover. For recommended bearing removers, refer to the Tool Compatibility Charts on page 1-15.

CAUTION

- Operate the bearing remover with the shaft threads properly engaged. A poor fit may lead to damage to the threads.
- Replace the remover if it is worn or damaged.

Do not reuse bearings that have been removed.

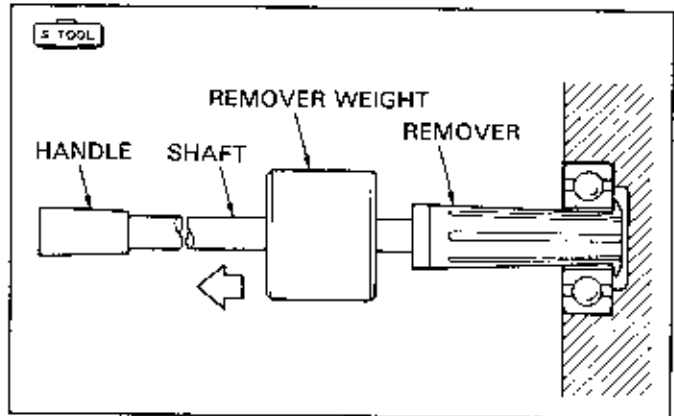

If the use of a bearing remover is not possible, remove the bearing by thermally expanding the case; slowly and uniformly heating the case with a heat gun (industrial dryer).

WARNING

- To avoid burns, wear insulated gloves when handling the heated case.

CAUTION

- Using a torch to heat the case may cause warping.

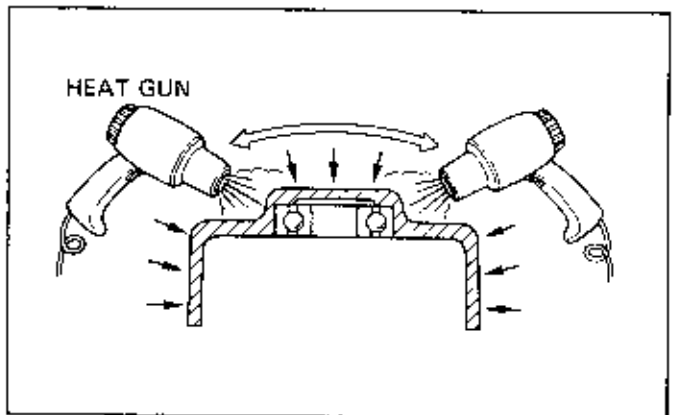

Remove the bearing from the shaft using a bearing puller. Avoid using a bearing that has been removed by pulling on the outer race with a bearing puller.

STOOL

Universal Bearing Puller

07631-0010000 or its equivalent should be used.

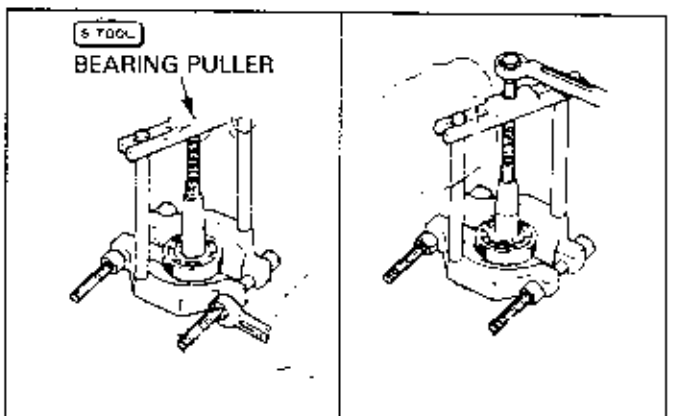

Remove the wheel bearing using a bearing remover shaft and remover head.

Do not reuse the removed bearing.

For recommended bearing remover shafts and remover heads, refer to the Tool Compatibility Charts on the following pages.

Installing Ball Bearings

Clean the bearing recess before the bearing is installed to ensure that it is free from dust or debris and that the bearing seats fully in its recess.

Caution should be taken regarding the direction in which the bearing is installed. Ball bearings are always installed with the manufacturer's name and size code facing out.

This is true for open, single sealed and double sealed bearings.

Apply the proper grease to the bearing before reassembly. The outer race should be installed with a driver, attachment and pilot.

The bearing must be installed in a parallel manner.

CAUTION

- Dust in the bearing recess or failure to install the bearing parallel to the case may result in bearing failure.

If a new bearing fails to fit tightly in the bearing recess, replace the case.

CAUTION

- The pilot must not be used if there is an oil guide plate that the pilot contacts when driving the bearing in. Before removing the bearing, make sure whether or not a pilot can be used.

When the bearing is installed onto a shaft, the inner race should be set by using an inner driver handle and inner driver.

Clean the bearing recesses thoroughly before installing the new bearing.

The bearing must be installed in a parallel manner.

CAUTION

- Dust in the bearing recess or improper fit may result in bearing failure.

If a new bearing fails to fit tightly onto the shaft, replace the shaft.

CAUTION

- An improper fit between the bearing and shaft may cause bearing damage when in use.

For adaptability between drivers, attachments and pilots, refer to the Tool Compatibility Charts on the following pages.

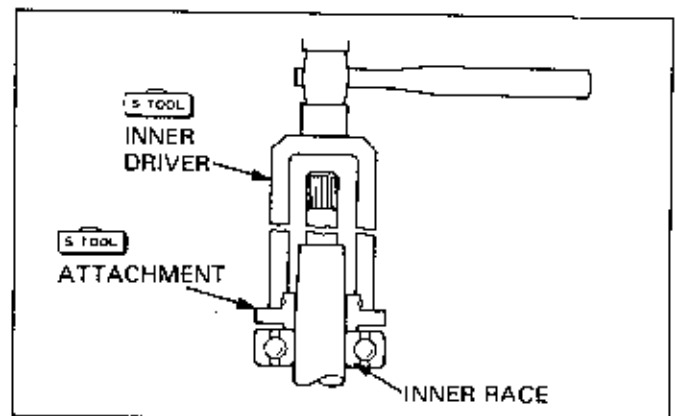
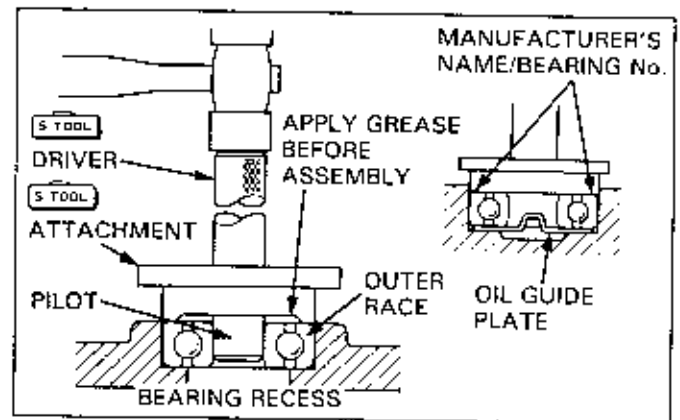
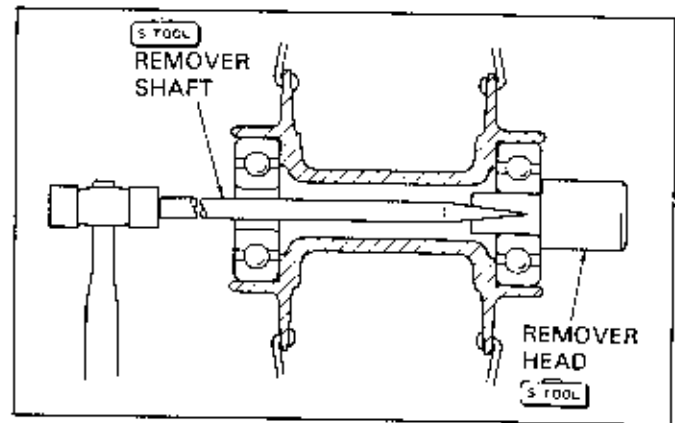

GENERAL INFORMATION

TOOL COMPATIBILITY CHART FOR STANDARD BEARINGS

Bearing Size

Select the bearing tool according to the size stamped on the bearing race.

A "U" or "Z" indicates a bearing with a metal shield or rubber seal respectively. These letters have no connection with bearing size and can be ignored.

- U: Single-sealed type
- Z: Single-sealed type
- UU: Double metal sealed type
- ZZ: Double rubber sealed type

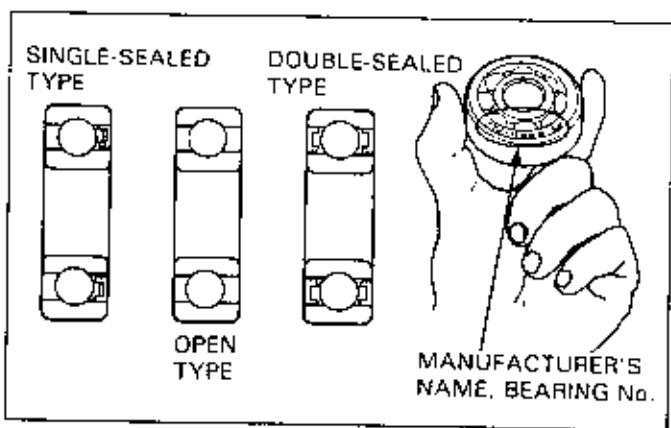

Bearing Remover Compatibility for Wheel Bearing

Use the remover heads listed below in combination with shaft (07746-0050100).

There is a kit comprising of 10-20 mm remover heads and shafts.

5-DOOL

Wheel Bearing Remover Kit: 07746-0050001

BEARING NUMBER	ID (mm)	BEARING REMOVER HEAD TOOL NUMBER
6000 6200 6300	10	07746-0050200
6001 6201 6301	12	07746-0050300
6002 6202 6302	15	07746-0050400
6003 6203 6303	17	07746-0050500
6004 6204 6304	20	07746-0050600

Bearing Remover Compatibility Table

BEARING NUMBER	ID	OD	TOOL NUMBER				
			BEARING REMOVER	SHAFT	HANDLE	WEIGHT	REMOVER SET
6000 6200 6300	10	26 30 35	07936-GE00200	07936-GE00100	Included with shaft	07741-0010201	07936-GE00000
6001 6201 6301	12	26 32 37	07936-1660110	07936-1660120	Included with shaft	07741-0010201	07936-1660001
6002 6202 6302	15	32 35 42	07936-KC10200	07936-KC10100	Included with shaft	07741-0010201	07936-KC10000, 07936-KC10500 (No including weight)
6003 6203 6303	17	35 40 47	07936-3710300	Included with remover	07936-3710100	07741-0010201	—
6004 6204 6304	20	42 47 52	07936-3710600	Included with remover	07936-3710100	07741-0010201	07936-3710001
6005 6205 6305	25	47 52 62	07936-4250100	Included with remover	07936-3710100	07741-0010201	—
6006 6206 6306	30	55 62 72	07936-8890200	Included with remover	07936-3710100	07741-0010201	07936-8890101
6007 6207 6307	35	62 72 80	07936-3710400	Included with remover	07936-3710100	07741-0010201	—

2. MAINTENANCE

FUEL LINE	2-2	DRIVE CHAIN	2-21
FUEL STRAINER SCREEN	2-2	DRIVE CHAIN SLIDER, CHAIN GUIDE, GUIDE SLIDER AND ROLLERS	2-24
THROTTLE OPERATION	2-3	DRIVE BELT	2-24
OIL PUMP AND OIL LINE (2-stroke separate oil supply motorcycles)	2-4	BELT CASE AIR CLEANER	2-25
CARBURETOR CHOKE	2-5	FINAL DRIVE OIL LEVEL	2-25
AIR CLEANER	2-6	BATTERY	2-26
AIR CLEANER CASE DRAIN TUBE (off-road motorcycles and ATVs)	2-7	BRAKE FLUID	2-27
CRANKCASE BREATHER	2-7	BRAKE SHOE WEAR	2-28
SPARK PLUG	2-8	BRAKE PAD WEAR	2-28
VALVE CLEARANCE	2-9	BRAKE SYSTEM	2-29
ENGINE OIL	2-11	BRAKE LIGHT SWITCHES	2-30
ENGINE OIL FILTER	2-13	HEADLIGHT AIM	2-31
ENGINE OIL FILTER SCREEN	2-14	CLUTCH SYSTEM	2-31
DECARBONIZING (2-stroke engine)	2-15	SIDE STAND	2-33
CARBURETOR SYNCHRONIZATION	2-16	SUSPENSION	2-34
CARBURETOR IDLE SPEED	2-17	SPARK ARRESTER (USA only)	2-35
RADIATOR COOLANT	2-17	NUTS, BOLTS, FASTENERS	2-36
COOLING SYSTEM	2-18	WHEELS/TIRES	2-36
SECONDARY AIR SUPPLY SYSTEM	2-19	STEERING HEAD BEARINGS	2-38
EVAPORATIVE EMISSION CONTROL SYSTEM	2-19	WHEEL ALIGNMENT (FOUR TRAX)	2-39
TRANSMISSION OIL (2-stroke engine)	2-20		

NOTE

- This section covers the normal inspections and adjustments that are necessary to maintain the vehicle in good condition. Perform this maintenance at each scheduled maintenance period. Refer to the Model Specific manual for the proper maintenance schedule and applicable items.

FUEL LINE

Check the fuel line for:

- Gasoline leakage
- Loose or improperly positioned line clip
- Deteriorated or damaged line

Replace any defective parts.

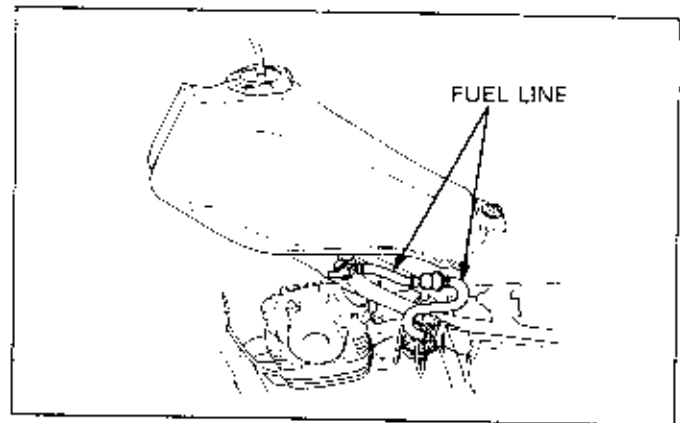

FUEL STRAINER SCREEN

Turn the fuel valve to "OFF" position.

Remove the strainer cap below the fuel valve, and drain the gasoline into a suitable container.

⚠ WARNING

- Gasoline is extremely flammable and is explosive under certain conditions.

Work in a well ventilated area. Keep cigarettes, flames or sparks away from the work area or any area where gasoline is stored.

Remove the O-ring and strainer screen.

Clean the cup and strainer screen with non flammable or high flash point solvent.

Replace the O-ring with a new one.

Reinstall the strainer screen, O-ring and cup, then tighten the cup to the specified torque.

CAUTION

- Overtightening the cup may break or deform the O-ring, causing a fuel leak.

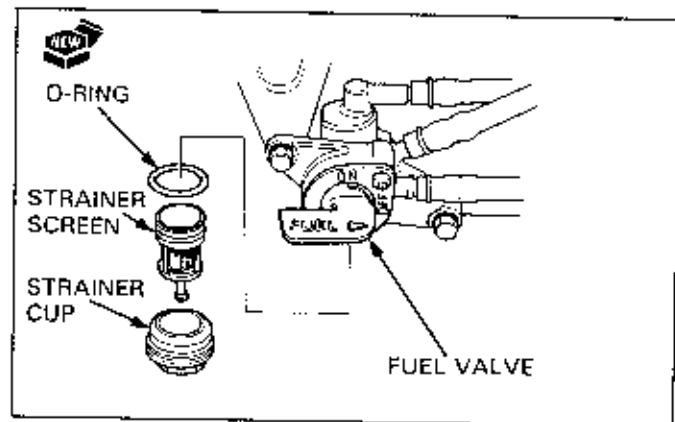

THROTTLE OPERATION

Check for any deterioration or damage to the throttle cable. Check that the throttle automatically closes completely in all steering positions.

If the throttle grip does not return properly, lubricate the throttle cable and overhaul and lubricate the throttle grip housing. If the throttle grip still does not return properly, the cable may need replacement.

With the engine idling, turn the handlebar all the way to the right and left to ensure that the idle speed does not change. If idle speed increases, check the throttle grip free play and the throttle cable connection.

▲WARNING

- Reusing a damaged or abnormally bent or kinked throttle cable can prevent proper throttle slide operation and may lead to a loss of throttle control while riding.

Throttle free play should be checked and adjusted as follows:

Throttle grip free play is correct if there is a prescribed amount of play on the outer circumference of the throttle grip flange.

Throttle lever free play is correct if there is a prescribed amount of play at the tip of the throttle lever.

Minor free play adjustments can be made with the adjuster on the throttle grip side.

Loosen the lock nut and turn the adjuster to obtain the desired amount of free play.

Tighten the lock nut after the adjustment has been made.

If the adjuster has a boot, reposition it properly after adjustment is made.

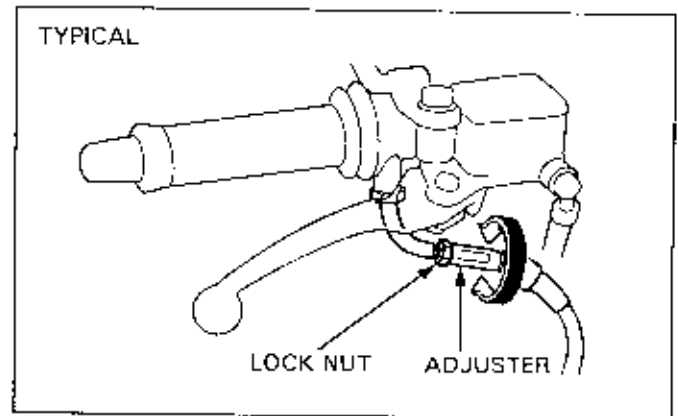
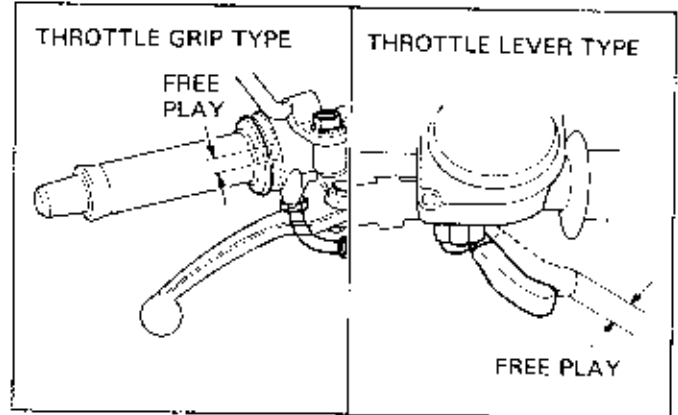
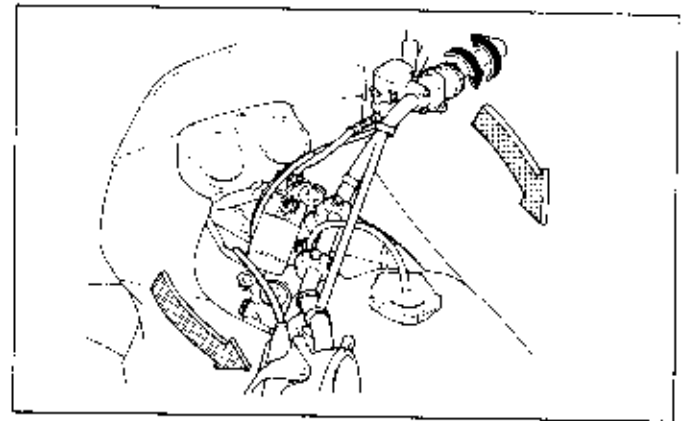

Major adjustments are made on the carburetor end of the cable, with one of the adjuster types shown here.

With a forced opening/closing-type throttle, the adjustment of free play can be made by loosening the lock nut on the pull side of the cable and turning the adjuster.

Tighten the lock nut after the adjustment has been made.

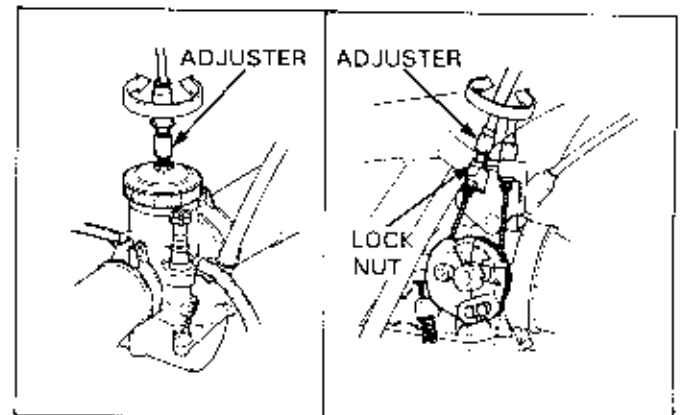

MAINTENANCE

If the throttle cable has an adjuster anywhere within its length besides the ends, major adjustment is made there.

Adjust the free play by loosening the lock nut and turning the adjuster.

Tighten the lock nut after the adjustment has been made. If the adjuster has a boot, reposition it properly after adjustment is made.

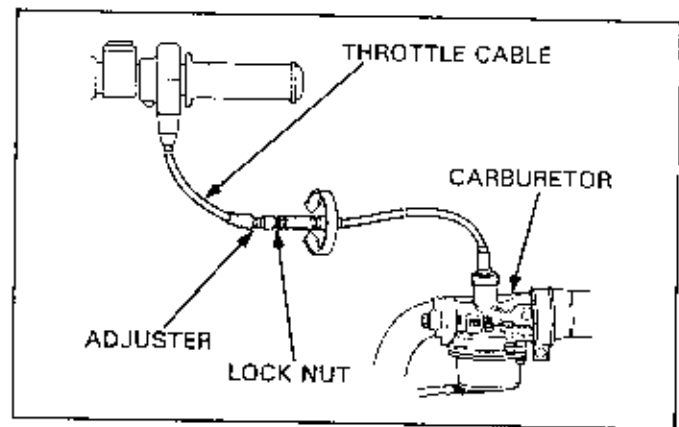

OIL PUMP AND OIL LINE (2-stroke separate oil supply motorcycles)

The oil supply on some 2-strokes is controlled by a throttle cable that is coupled with an oil pump.

Oil flow is regulated, in a direct relation to throttle movement and position, by a combined oil control/throttle cable that simultaneously moves the throttle slide in the carburetor and a control arm on the oil pump.

When the inner cable of the oil control cable stretches, the amount of the oil flow changes and is not suitable for the size of throttle opening. Therefore, it is necessary to inspect and readjust it periodically.

There is a matching mark on the oil pump that must be aligned with the matching mark on the control arm, pump body, etc. Refer to the Model Specific manual before making any adjustments.

Oil line

Check the oil line for leaks, deterioration or damage: Replace parts if necessary.

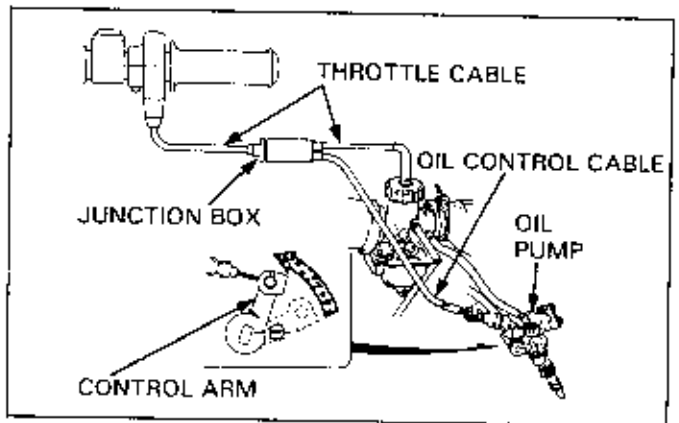

Oil strainer

Loosen the tube clip located on the bottom of the oil tank. Drain oil into a suitable container.

Remove the oil strainer joint from the bottom of the tank.

Remove the strainer screen.

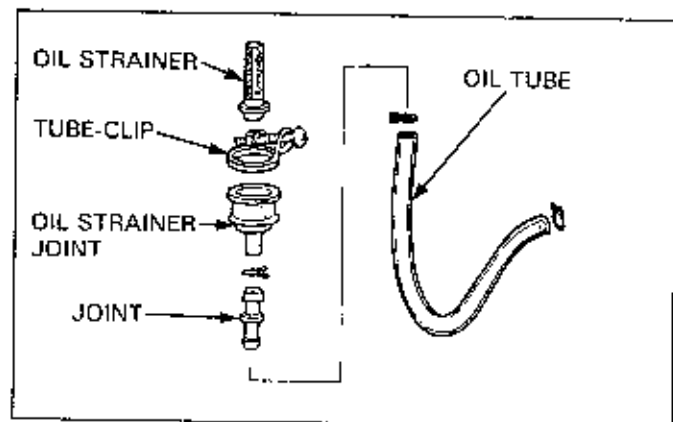

Clean strainer screen by blowing it out with compressed air. To replace screen, reverse the removal procedure. After pouring 2-stroke engine oil back into the tank, be sure to remove the air in both oil tube and oil pump (See page 4-11).

NOTE

- Check each part for oil leakage after completing the oil strainer cleaning and oil tube and pump air bleed procedures.

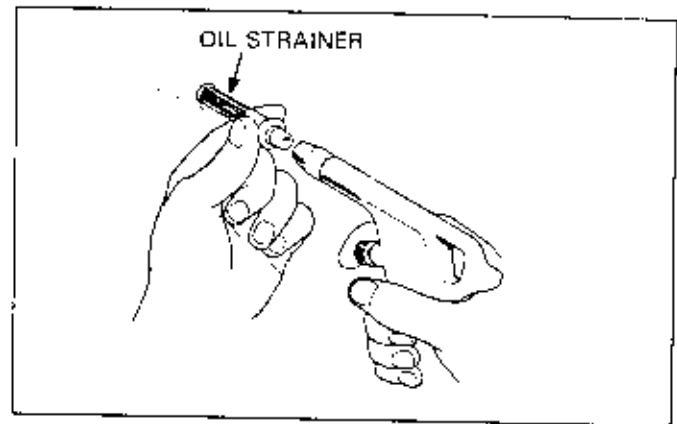

CARBURETOR CHOKE

MANUAL CHOKE

On the manual choke system, check to see if the choke lever (or knob) can be opened and closed completely.

Inspect the choke cable to see if it is bent, crimped or damaged in any way.

⚠ WARNING

- Reusing a damaged or abnormally bent or kinked throttle cable can prevent proper throttle slide operation and may lead to a loss of throttle control while riding.

Check to be sure that cable movement is correct on machines with manually operated chokes.

Check by pushing with your finger to see if there is a maximum of 1–2 mm of free play in the inner choke cable when the choke lever is in its completely off position.

If the amount of free play is not sufficient, loosen the cable clamp screw and adjust the play of the inner cable by moving the position of the outer cable. Tighten the cable clamp securely when the adjustment is complete.

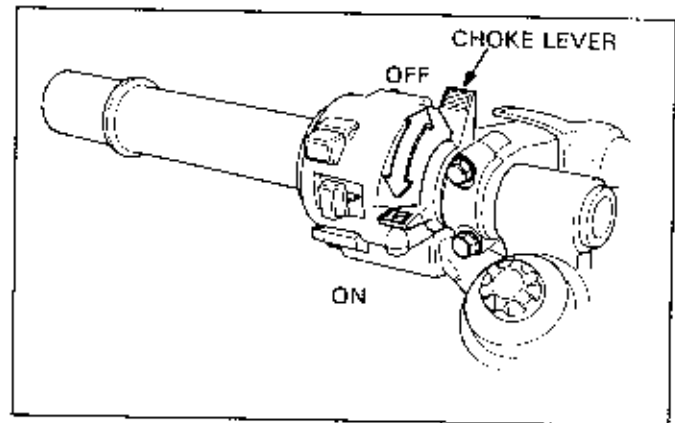

BYSTARTER CHOKE

The choke action on motorcycles equipped with auto by-starter-type choke system can be checked by the way engine starts and runs.

NOTE

- Difficulty in starting before it is warmed up (easy once it is warmed up): starter valve is not completely opened (off).
- Idle speed is erratic even after warm-up (imperfect combustion): starter valve is not completely closed (on).

When the above-mentioned symptoms occur, inspect and overhaul the choke system according to the procedures specified in the Model Specific manual. If you find nothing wrong with it, proceed with the overhaul of the other items on the breakdown diagnosis list.

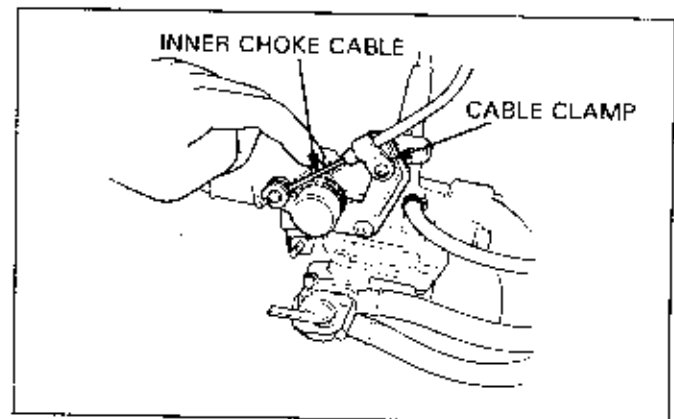

AIR CLEANER

When the element becomes dirty, the air/fuel mixture will become too rich.

Periodic cleaning or replacement is necessary. Vehicles used in dusty areas require more frequent inspections.

When replacing the air cleaner element, be careful of the following points.

NOTE

- If the element joint has a rubber seal, the joint will become more airtight if a small amount of grease is applied to the seal.
- Check to see that both the air cleaner and the holder are properly secured and do not contain any dust or dirt.

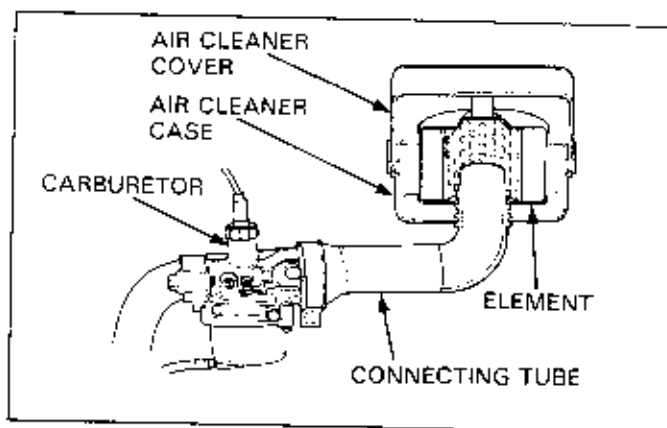

Oiled Urethane Foam Element

Remove the air cleaner from the holder and wash away any accumulated dust or dirt, by gently squeezing it in non flammable or high flash point solvent.

WARNING

- Using gasoline or low flash point solvents for cleaning parts may result in a fire or explosion.

CAUTION

- Cleaning the element with gasoline or any acid, alkaline, or organic, volatile type oil may cause improper ignition, deterioration of the element, or a loosening of the element adhesive.

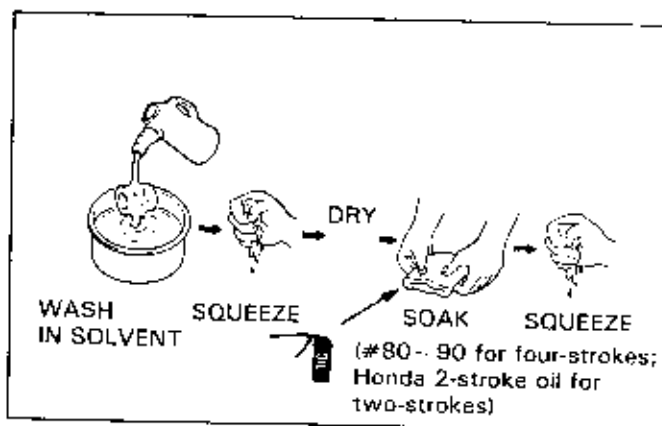

Be sure to allow the element to dry thoroughly before applying oil. Otherwise, the oil will be diluted by the solvent and the filtering ability of the filter will be much less effective.

Spread clean #80-90 gear oil (4-strokes; Honda 2-stroke oil for 2-strokes) on the element, rubbing in thoroughly over the surface with both hands, and then squeeze out any excess oil.

CAUTION

- Using air filter oil when riding in extremely dusty conditions prevents premature engine wear due to dust/dirt drawn into the engine. Apply air filter oil to the entire surface of the element and rub it with both hands to saturate the element with oil. Squeeze out excess oil.

Paper Element

If the surface of the element is dirty, remove the dust first by tapping the element gently. Then, blow away any remaining dust on the surface of the filter with compressed air from the inside (or carburetor side) toward the outside.

Viscous Paper Element

This particular type of paper element cannot be cleaned as the element contains a dust adhesive. These must be changed periodically.

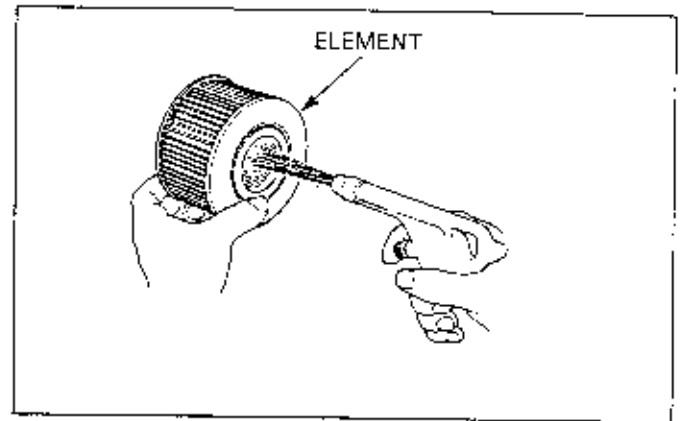

**AIR CLEANER CASE DRAIN TUBE
(off-road motorcycles and ATVs)**

Loosen the drain tube clip and remove the drain tube to empty any accumulation of fluids or dirt from the air cleaner case into a proper container.

Check the drain tube for damage and replace if necessary. Reinstall the drain tube and set the clip in place.

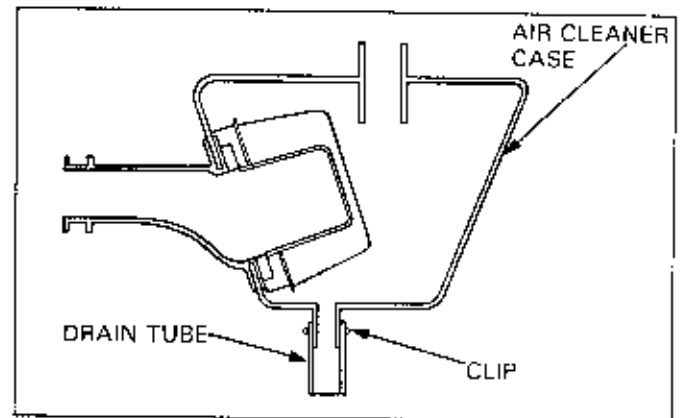

CRANKCASE BREATHER

Some motorcycle engines are equipped with a closed crankcase system to prevent discharging crankcase emissions into the atmosphere. Blow-by gas is returned to the combustion chamber through the air cleaner and carburetor.

A breather separator is necessary within the system to prevent moisture from contaminating the engine. Vapor is allowed to pass through the air cleaner and into the engine to be burned off. Moisture is collected in a sealed drain tube. Periodic maintenance is to remove the drain plug and drain deposits into a suitable container, then reinstall the drain plug.

A portion of the drain tube is transparent so it is easy to confirm the amount of accumulation.

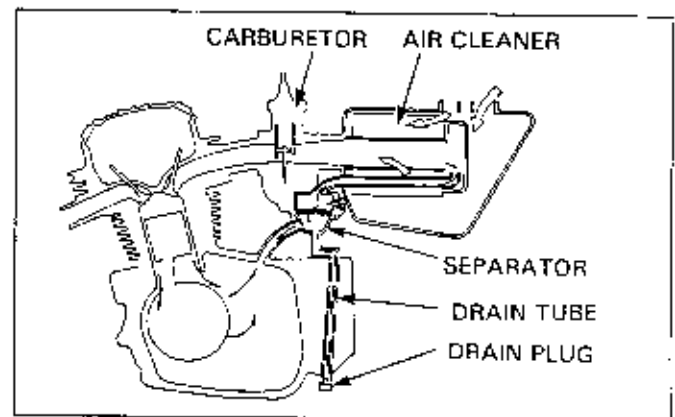

MAINTENANCE

SPARK PLUG

NOTE

- Clean around the spark plug seat with compressed air before removing, and be sure that no debris is allowed to enter the combustion chamber.

Remove the spark plug cap and then remove the spark plug and inspect or replace as described in the Model Specific manual maintenance schedule.

Inspection

Check the following and replace if necessary.

- insulator for damage
- electrodes for wear
- burning condition, coloration;
 - dark to light brown shows good condition.
 - excessive lightness shows faulty ignition timing or lean mixture.

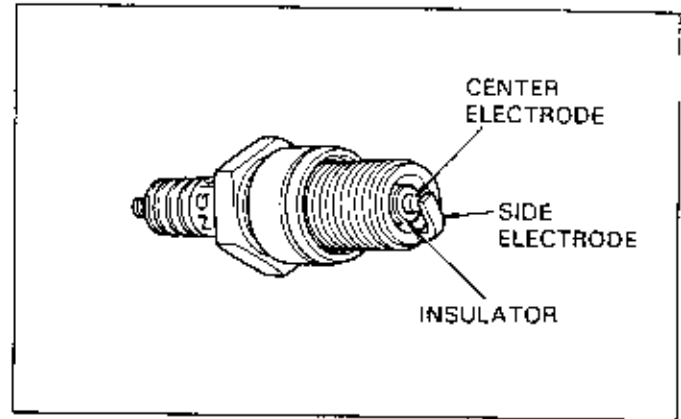

REUSING A SPARK PLUG

Clean the spark plug electrodes with a wire brush or special plug cleaner.

Check the gap between the center and side electrodes with a wire-type feeler gauge. If the gap is not as specified, bend the side electrode to adjust.

Replace the spark plug in the cylinder head and hand tighten. Torque to specification.

CAUTION

- Make sure there is no dirt or debris on the seat of the spark plug hole before inserting the spark plug.
- To prevent damage to the cylinder head, hand-tighten the spark plug before using a wrench to tighten to the specified torque.

REPLACING A SPARK PLUG

In the case of new spark plugs, set the gap with a wire-type feeler gauge. Install and hand tighten, then tighten about 1/4 of a turn after the sealing washer contacts the seat of the plug hole. Reused plugs should be tightened to the specified torque.

Do not overtighten the spark plug.

CAUTION

- Overtightening the spark plug may damage the cylinder head. Be sure to use the proper spark plug torque.

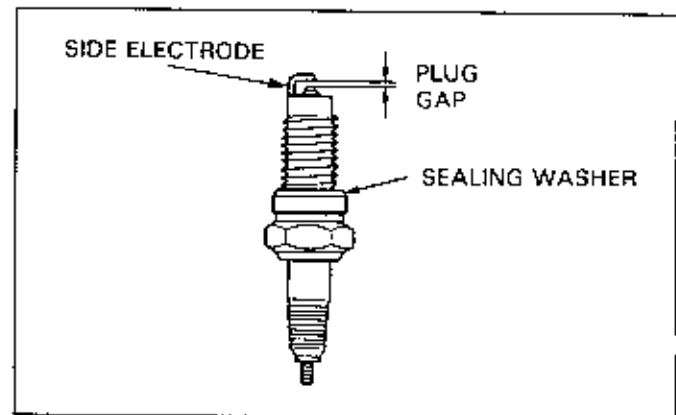

VALVE CLEARANCE

Adjustment is unnecessary on motorcycles equipped with hydraulic lash adjusters (hydraulic tappet). However, appropriate clearance is needed between both the intake and exhaust valves and the valve opening/closing mechanisms in all other 4-cycle engines. This clearance allows a change in the size of the valve by thermal expansion as the heat of the combustion chamber is transmitted to the valve.

If there is too much clearance, it may result in engine noise (tappet noise). If there is too little clearance, the valve is pushed during the heated period, causing a drop in compression, resulting in bad idling and, eventually, burned valves.

NOTE

- Inspect and adjust the valve clearance when the engine is cool (under 35°C/95°F).

Inspection and adjustment of valve clearance should be performed with the piston at top dead center of the compression stroke. This position can be obtained by confirming that there is slack in the rocker arm when the stamped "T" mark on the flywheel rotor and the index mark on the crankcase cover are aligned. If there is no slack in the rocker arm, even when the T-mark and index mark are aligned, it is because the piston is moving through the exhaust stroke to top dead center. Turn the crankshaft one full rotation and match up the T-mark again. The piston will then be at the top of the compression stroke (top dead center). On in-line 4-cylinder engines with the firing order 1-2-4-3, the inspection of valve clearance can be conducted by rotating the crankshaft twice. After the above procedure has been properly carried out, the inspection and adjustment of all cylinders is complete.

(In-line 4 cylinder engines are numbered 1-2-3-4 starting from the left cylinder.)

Cylinder at top of compression stroke	Cylinder number			
	#1	#2	#3	#4
#1	IN,EX	EX	IN	—
#4	—	IN	EX	IN,EX

On V-twin and V-4 engines, inspection and adjustment are performed by placing each cylinder in the compression, top dead center position.

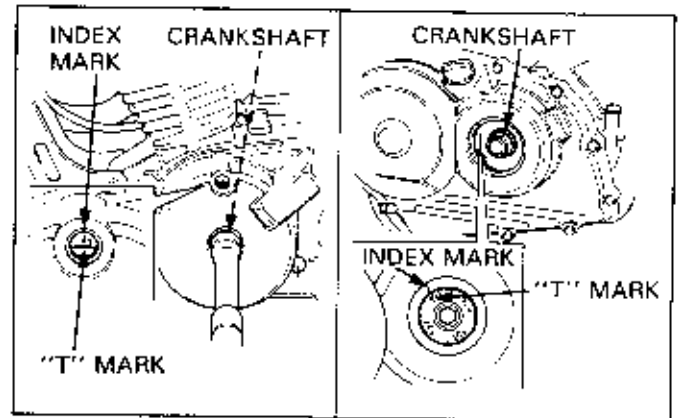
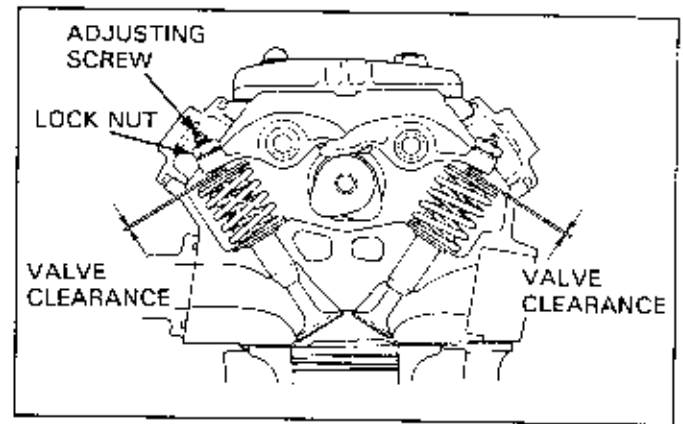

MAINTENANCE

The valve clearance adjustment is correct when the specified feeler gauge fits snugly, but the next size larger feeler gauge will not fit in.

NOTE

- On motorcycles that have a decompression mechanism which lifts the valve when starting the engine, the adjustment for decompression must be carried out first in order to provide an accurate valve clearance inspection.

Valve clearance inspection on engines with common, screw-type adjusters is measured by inserting a feeler gauge directly between the end of valve stem and the adjusting screw.

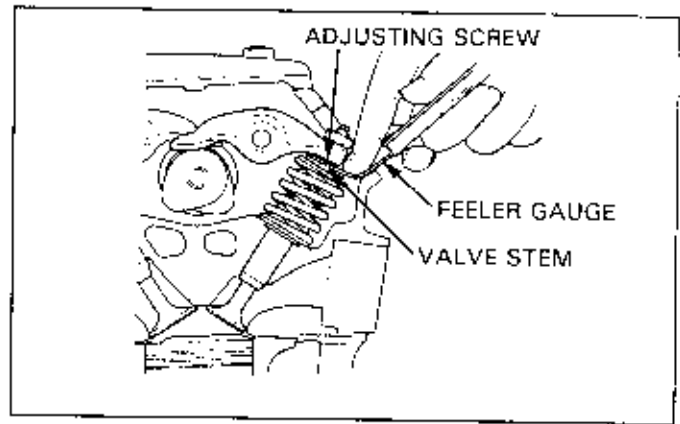

In the case of one-sided ball-joint type engines, the clearance is measured by inserting the feeler gauge between the rocker arm and the cam.

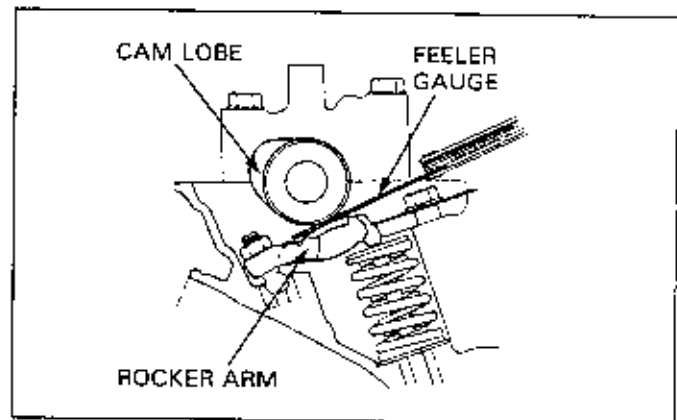

In the case of valve lifters in direct push-type engines, the clearance between the cam lobe and lifter or shim is measured with a feeler gauge.

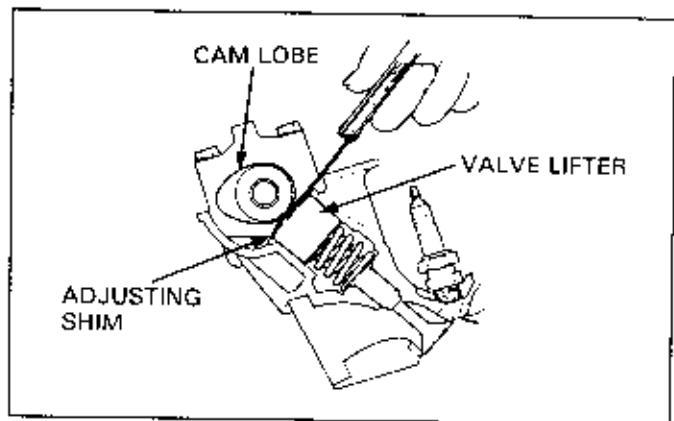

If adjustment is needed, loosen the lock nut and the adjusting screw and insert the proper dimension feeler gauge. Proper intake and exhaust valve clearance dimensions are given in the Model Specific manual.

Turn the adjusting screw and adjust the clearance until the inserted feeler gauge can only be pulled out with a little difficulty.

Leaving the feeler gauge inserted, and being careful not to turn the adjusting screw, tighten the lock nut to the designated torque.

CAUTION

- An improperly tightened lock nut may loosen and cause engine damage.

Be sure to use any special tools specified for valve adjustment.

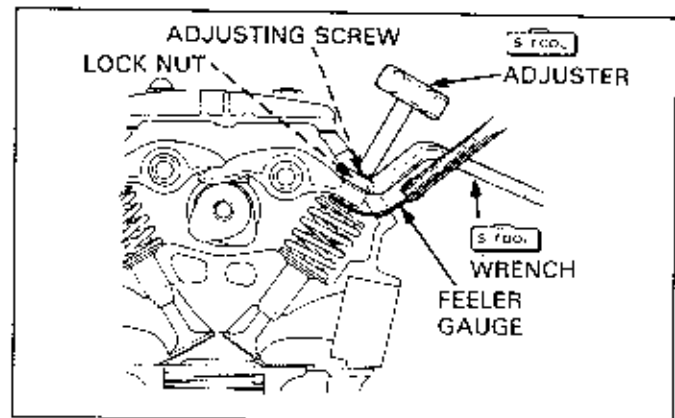

When the lock nut is tightened, the clearance may change. So be sure to recheck the clearance after tightening the locknut.

Adjustment is properly carried out only when the feeler gauge can be pulled out with a little difficulty. If tension on feeler gauge is too great or too little, readjust.

In the case of valve lifters in direct-push-type engines, change the shim and adjust the valve clearance. Refer to the Model Specific manual for the appropriate adjustment method.

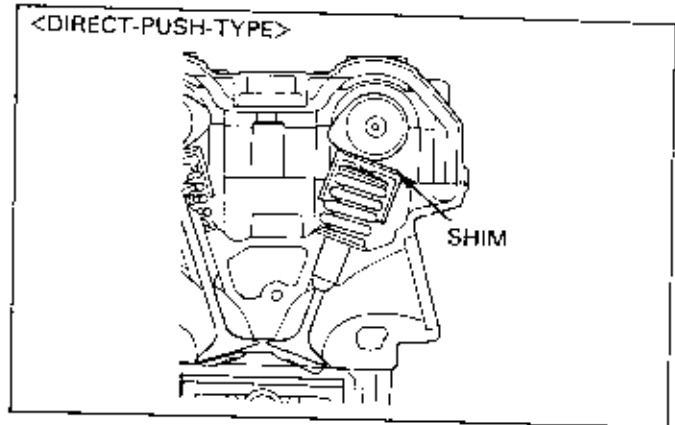

ENGINE OIL

NOTE

- Do not screw in the oil cap/level gauge when checking oil level.
- The oil level cannot be correctly measured if the motorcycle is not supported perfectly upright on a level surface.
- As the oil is gradually consumed, it is necessary to periodically check the oil level and replenish the oil volume to its proper level.
- If the oil level is too high, overall engine performance and the actuation of the clutch may be effected. Too little oil may cause engine overheating as well as premature wear to various parts.
- If a different brand or grade of oil or low quality oil is mixed when adding oil, the lubricating function deteriorates.
- Check the oil level only after starting the engine and allowing the oil to circulate through the engine thoroughly. It is especially important to run the engine before checking the oil level on a dry sump engine, due to the comparatively large volume of oil.

4-stroke, Wet Sump Engines:

Start the engine and let it idle for a few minutes.

Stop the engine, remove the oil level gauge and wipe the oil from the gauge with a clean cloth.

Two or three minutes after stopping the engine; with the motorcycle in an upright position, insert the level gauge into the engine without screwing it in.

The engine contains a sufficient amount of oil if the level is between the upper and lower lines on the gauge.

If the oil level is near or below the lower line, add the recommended engine oil up to the upper line.

Refer to the Model Specific manual for the recommended oil.

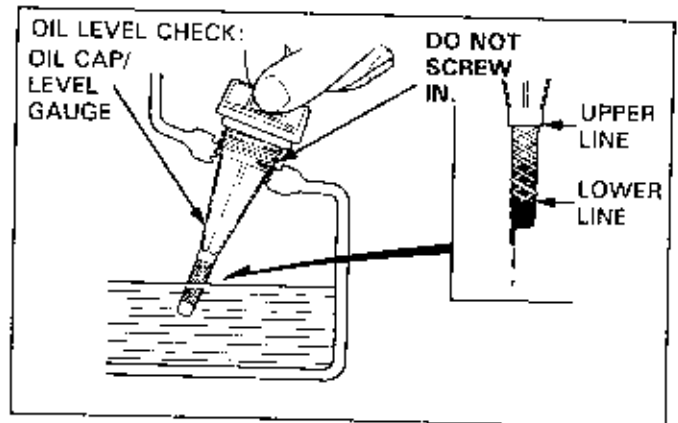

MAINTENANCE

4-stroke, Dry Sump Engines:

Start the engine and allow the engine oil to warm up thoroughly.

NOTE

- Do not snap the throttle or the oil level reading will be inaccurate.

Allow the engine to idle for about 3 minutes and stop the engine. Remove the oil level gauge immediately and wipe it clean. With the motorcycle in an upright position on a level surface, check the oil level by inserting the gauge into the oil tank without screwing it in.

The engine contains a sufficient amount of oil if the oil level is between the upper and lower lines on the gauge.

If the oil level is near or below the lower line, add the recommended engine oil up to the upper line.

See the Model Specific manual for the recommended oil.

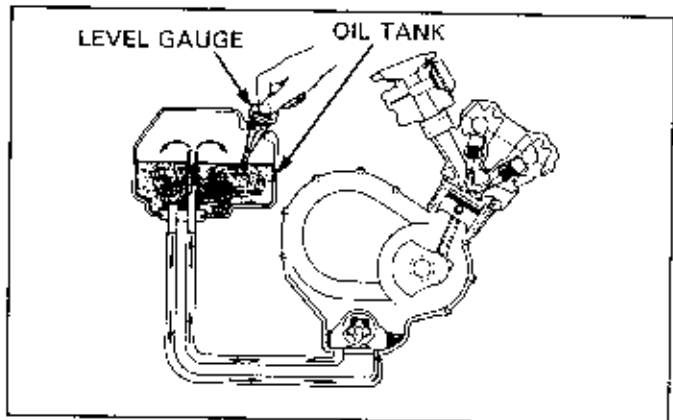

Leak Inspection:

Inspect to see that there is no oil leaking from any part of the engine, oil pipes, oil hoses, etc.

If any oil leaks are detected, perform the proper maintenance to correct the problem.

Oil Change:

In 4-stroke engines, sludge can build up, due in part to the gas which blows past the piston rings and the gasoline composition contaminates the oil, causing a weakening of oil's performance. To alleviate this contamination problem, change the oil periodically.

Because many newly machined surfaces are moving against one another for the first time in new motorcycle engines, a noticeable amount of powdered metal circulates with the oil during this early stage of use.

Therefore, it is extremely important to change the engine oil and to replace the oil filter or clean the oil strainer screen at the first maintenance interval (after 1,000 km/600 miles) in order to prolong engine life.

See the Model Specific manual for oil change intervals.

NOTE

- Draining the engine oil while it is still warm is the most rapid and efficient method.

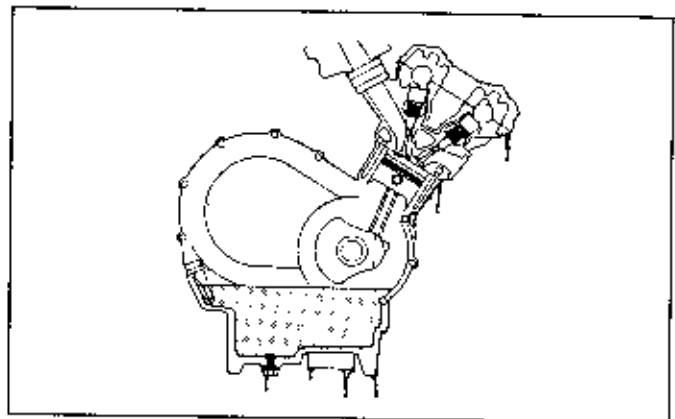

Remove either the oil level gauge or filler cap to allow rapid draining.

Remove the oil drain bolt at the bottom of the crankcase and drain the oil.

WARNING

- Used engine oil may cause skin cancer if repeatedly left in contact with the skin for prolonged periods. Although this is unlikely unless you handle used oil on a daily basis, it is still advisable to thoroughly wash your hands with soap as soon as possible after handling used oil.

After the oil is completely drained, clean and install the drain bolt and sealing washer and tighten to the designated torque.

NOTE

- Replace the sealing washer if it is damaged.

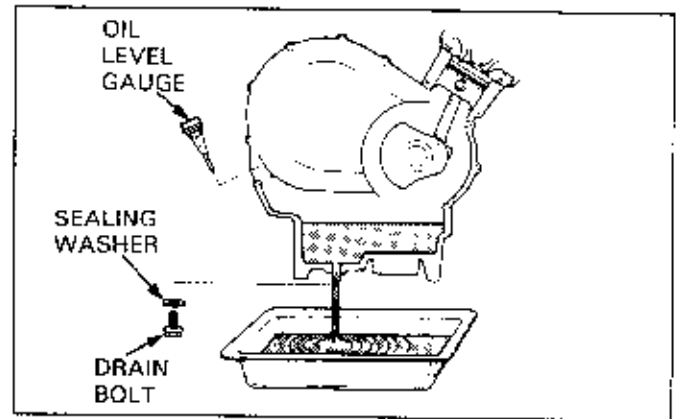

Pour the recommended engine oil into the engine through the oil level gauge/filler hole. The oil filler hole and cap are separated from the oil level gauge on some engines.

Pour in the oil, periodically checking with the level gauge until the upper line on the gauge is reached.

Install and tighten the level gauge and/or filler cap after replenishing.

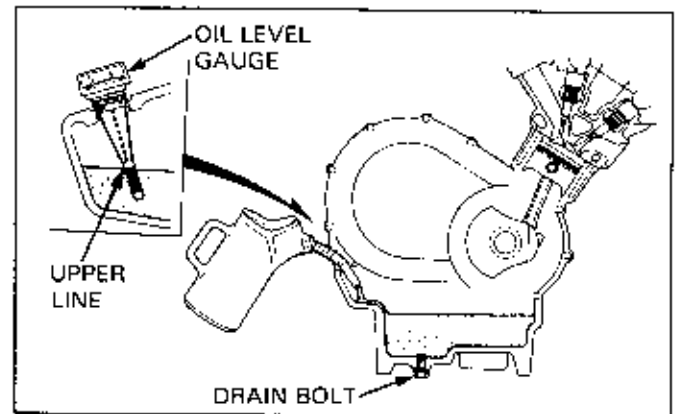

ENGINE OIL FILTER

Small dust particles and metal dust which do not filter through the net-type oil strainer screen are trapped by the paper oil filter. When the filter is clogged, the oil flow is reduced and contaminants may reach various parts of engine by way of the relief passage, causing premature wear and possible damage.

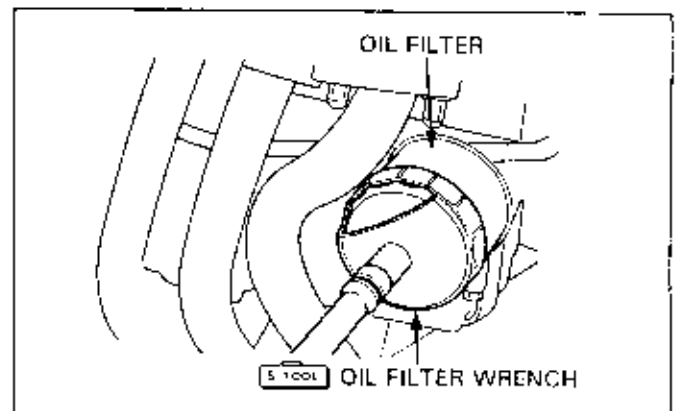

MAINTENANCE

Cartridge-Type Paper Filter

Cartridge-type oil filters are removed using a filter wrench.

⚠ WARNING

- Engine and exhaust system parts become very hot and remain hot for some time after the engine is run. Wear insulated gloves or wait until the engine and exhaust system have cooled before handling these parts.

Clean the filter area of the engine with a clean cloth.

Spread engine oil thinly over the O-ring of the new filter and attach filter to the engine.

Tighten the oil filter with the proper filter wrench.

🔧 TOOL

Oil Filter Wrench

(For small-type cartridge)

07HAA-PJ70100

(For large-type cartridge)

07912-6110001

Torque (Small-type cartridge): 10 N·m (1.0 kg·m, 7 ft·lb)

(Large-type cartridge): 18 N·m (1.8 kg·m, 13 ft·lb)

Confirm that there is no oil leakage by starting the engine after the engine oil has been set at its proper level.

Run the engine for about a minute, then stop it and inspect carefully for leaks.

Element-Type Paper Filter

Remove the oil filter cover and replace the filter element. Reinstall the cover with a new O-ring.

NOTE

- Install the element with the rubber seal side facing out, making sure that the spring is installed between the element and crankcase.
- Replace the O-ring on the filter cover with a new one.

Replenish the engine oil with the proper type and viscosity, and to the proper level. Always run the engine and check for oil leaks after an oil or oil and filter change.

ENGINE OIL FILTER SCREEN

Check to see if there is any dirt or debris on the oil filter screen which might hinder the flow of oil. Remove and clean the screen in solvent if any deposits are found on the screen. Refer to the Model Specific manual for oil filter screen removal, cleaning and installation procedures for specific models.

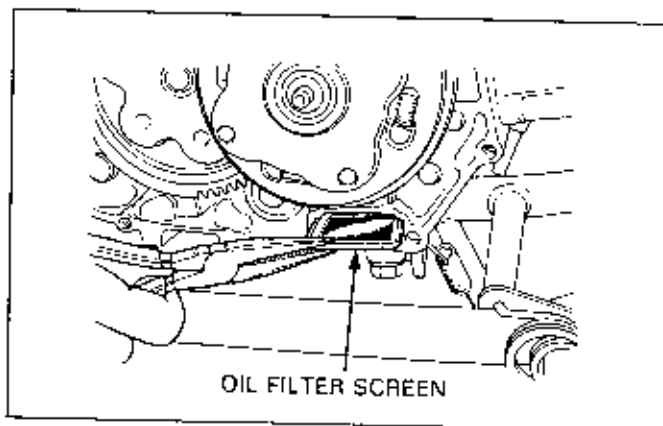
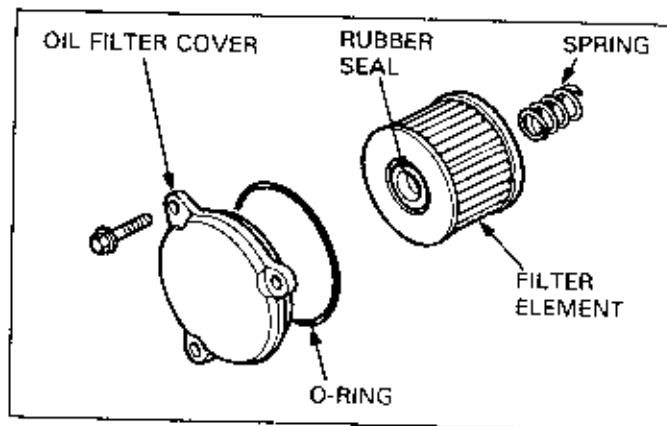
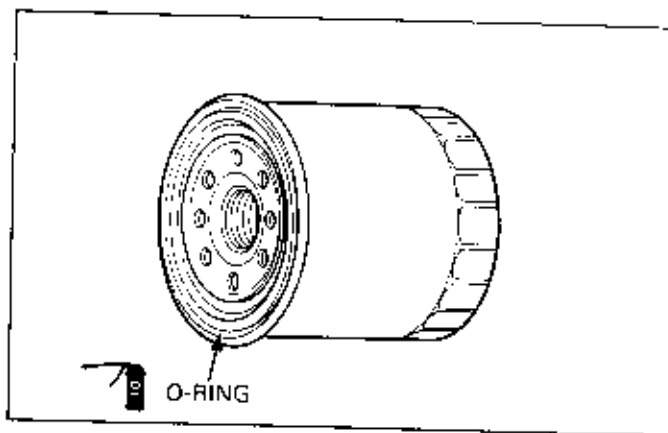

DECARBONIZING (2-stroke engine)

Carbon accumulation occurs more rapidly in 2-stroke engines than 4-stroke engines because 2-stroke engines burn engine oil. If the build up of carbon is not removed periodically, the carbon accumulation increases to an excessive amount, causing hot spots on the cylinder head and piston crown. This may cause knocking due to preignition and may cause poor engine performance. Accumulated carbon in the exhaust port hinders the flow of the exhaust, causing a drop in power output. Therefore, removal of accumulated carbon should be performed according to the maintenance schedule in the Model Specific manual.

CAUTION

- When removing carbon, be careful not to damage the combustion chamber, piston and cylinder.

Take off the cylinder head and remove the carbon from the piston crown when the piston is in the top dead center position.

Remove carbon from the combustion chamber area of the cylinder head.

Take off the cylinder and remove accumulated carbon from the walls of the exhaust port.

Remove any remaining carbon within the cylinder.

In liquid-cooled engines, be sure to remove carbon particles that may have fallen into the coolant jackets around the cylinder by blowing them out with compressed air.

Refer to the Model Specific manual for the proper procedures for cylinder and cylinder head removal and installation.

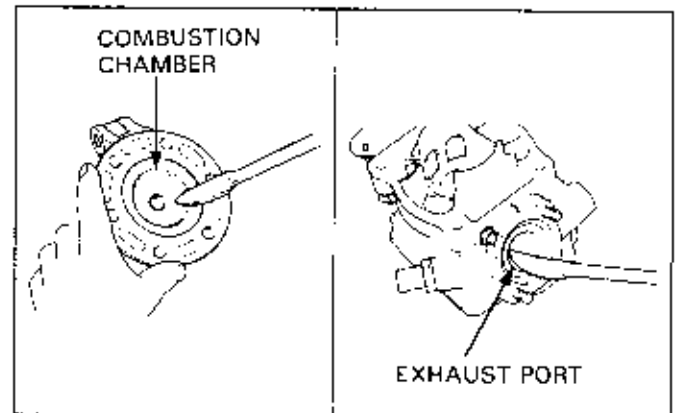
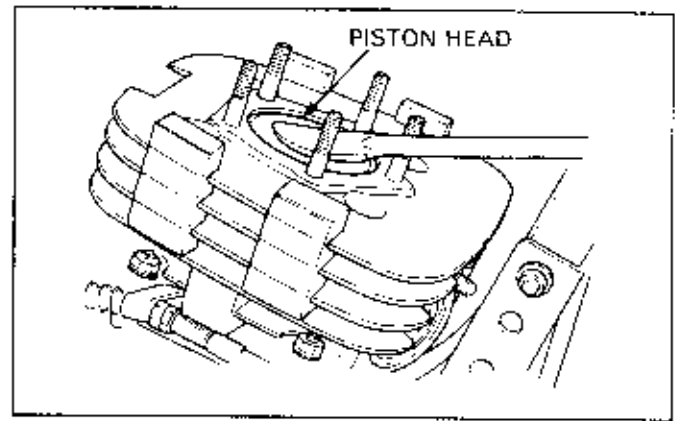

CARBURETOR SYNCHRONIZATION

NOTE

- Carburetor synchronization adjustment is required to adjust the throttle valve opening, and to synchronize the vacuum in each carburetor's intake port, whenever 2 or more carburetors are reassembled.
- Synchronize the carburetors with the engine at normal operating temperature, the transmission in neutral and the motorcycle on its center stand.
- Carburetor numbers match the cylinder number.

Remove the plugs from each cylinder head port and install the vacuum gauge adapters.

If the motorcycle is equipped with the fuel auto valve, disconnect the vacuum tube from the intake manifold of the carburetor, draw vacuum and pinch the tube with a clip as shown.

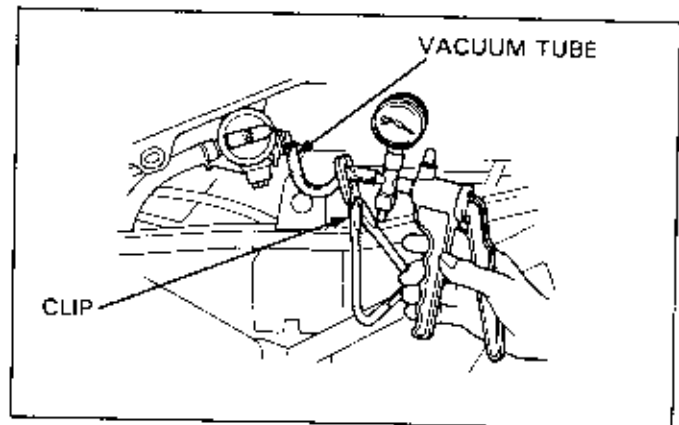
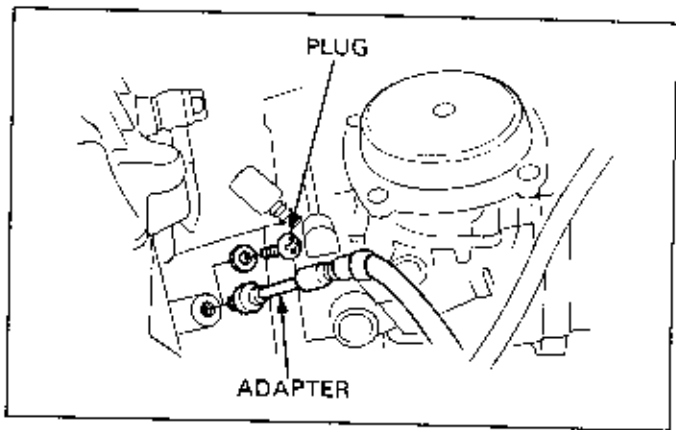

Connect the vacuum gauge.

S TOOL

Vacuum Gauge

07404-0030000
(for both two and four carburetor engines)
07404-0020000
(for dual carburetor engines)

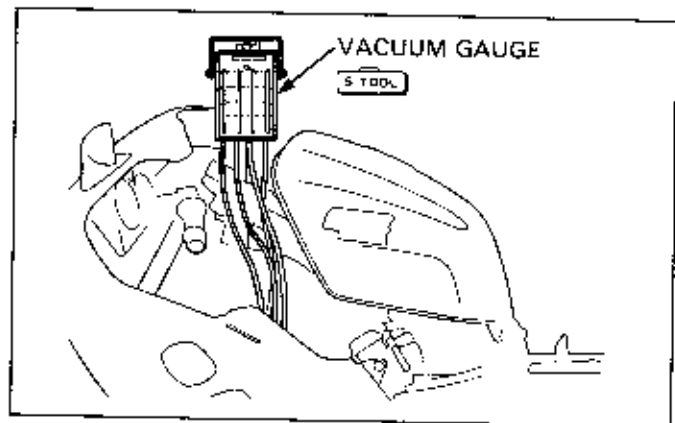

1. Adjust the idle rpm to the specified idle speed. (Refer to the Model Specific manual for the specification.)
2. Turn the synchronization adjusting screw so that the difference between the vacuum in the base carburetor's intake port and the vacuum in the other carburetor's intake port is below the specification. (Refer to the Model Specific manual for base carburetor, location of each synchronization adjusting screw and difference in vacuum between the carburetors.)
3. Be sure that the synchronization is stable by snapping the throttle grip several times.
4. Repeat steps 1 through 3 for each carburetor.
5. Snap the throttle grip several times and recheck the idle speed and differences in vacuum between each carburetor.

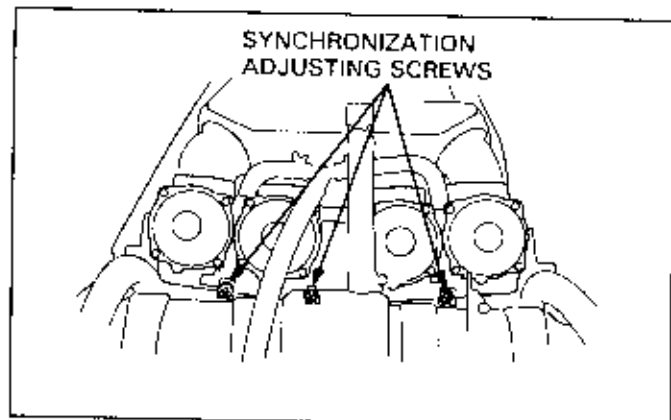

CARBURETOR IDLE SPEED

Check for any unusual noise while the engine is idling. If noise is detected, investigate with a stethoscope to locate the source. Carry out the appropriate maintenance inspection, depending on results of noise investigation.

Check to see that the engine speed increases smoothly from idle. Check the idle speed and adjust if necessary by turning the throttle stop screw.

NOTE

- Check and adjust after first warming up the engine. There are differences in idle speed between hot and cold engines.
- Place the vehicle on the center stand or support upright on level ground when checking and adjusting the idle speed. If the vehicle is tilted, there will be fluctuations in fuel flow from the carburetor which prevents an accurate determination of the idle speed.

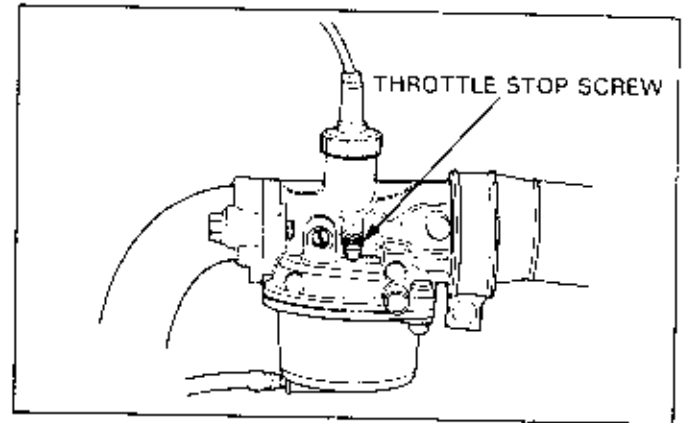

RADIATOR COOLANT

WARNING

- Wait until the engine is cool before removing the radiator cap. Removing the cap while the engine is hot and the coolant is under pressure may cause serious scalding.
- Radiator coolant is poisonous. Take care to avoid getting coolant in your eyes, on your skin, or on your clothes.
- If coolant gets in your eyes, flush repeatedly with water and contact a doctor immediately.
- If coolant is accidentally swallowed, induce vomiting and contact a doctor immediately.
- KEEP OUT OF REACH OF CHILDREN.

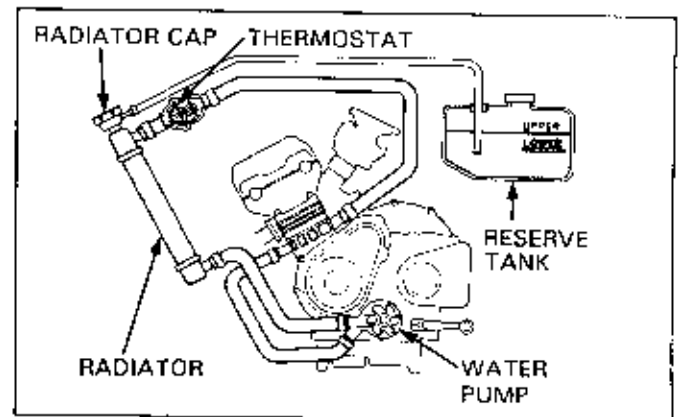

Coolant evaporates naturally, so check it regularly.

Coolant is both an antifreeze and an anti-rust agent.

CAUTION

- Be sure to use the proper mixture of antifreeze and distilled water to protect the engine.
- Use distilled water. Tap water may cause the engine to rust or corrode.

MAINTENANCE

LEVEL CHECK

Always check the coolant level with the motorcycle in a vertical position on a flat, level surface.

Always check the coolant level at the reserve tank (not the radiator) after the engine has been warmed-up.

Check to see if the coolant level in the reserve tank is somewhere between the upper and lower lines.

If the level is somewhere between the upper and lower lines or below the lower line, add a 50/50 mixture of antifreeze and distilled water to the upper line. (See Coolant Mixture Preparation page 5-6)

Check to see if there are any coolant leaks when the liquid level decreases very rapidly.

If the reserve tank becomes completely empty, there is a possibility of the air getting into the cooling system. So, be sure to remove all air from the cooling system as described on page 5-7.

NOTE

- The effectiveness of coolant decreases with the accumulation of rust or if there is a change in the mixing proportion during usage. Therefore, for best performance, change the coolant regularly. (See page 5-6)

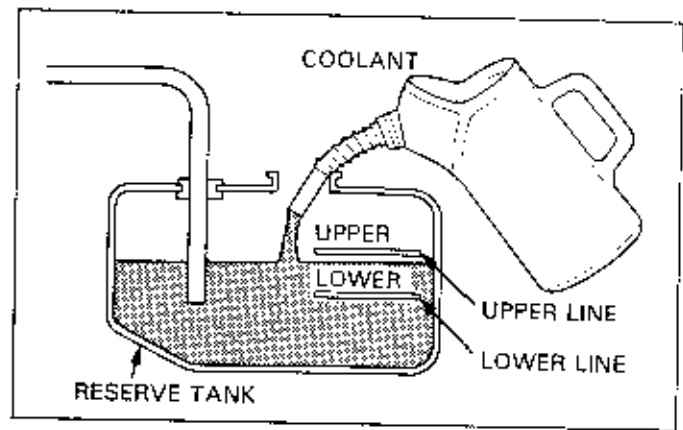

COOLING SYSTEM

⚠ WARNING

- To prevent injury, keep your hands and clothing away from the cooling fan. It may start automatically, without warning.

Check the radiator air passages for clogging or damage, straighten bent fins with a small, flat blade screwdriver and remove insects, mud or other obstructions with compressed air or low water pressure. Replace the radiator if the air flow is restricted over more than 1/3 of the fin surface.

Remove the body panels and fuel tank, and check for any coolant leakage from water pump, water hoses, and hose joints.

Check for any deterioration or damage to the water hoses. A rubber hose deteriorates naturally over time due to heat and wear. If the hose deteriorates too much, it will rupture due to the pressure in the cooling system. Squeeze the hose and look for cracks.

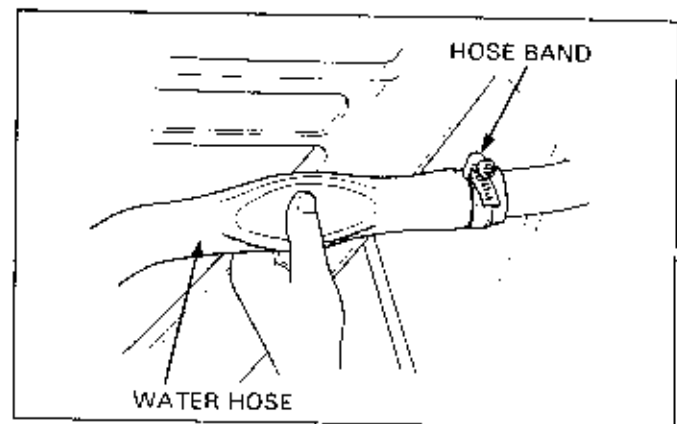
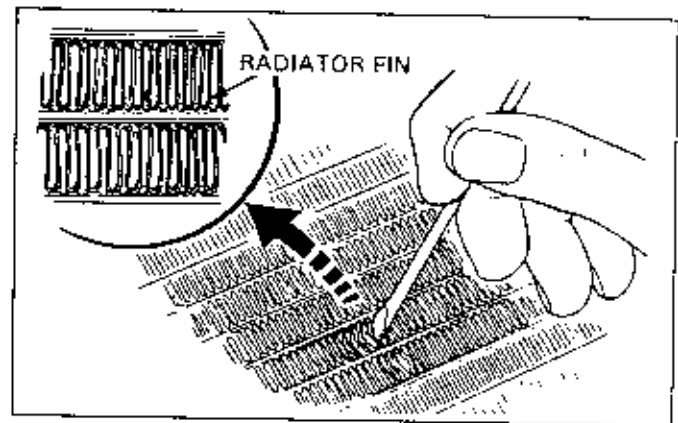

SECONDARY AIR SUPPLY SYSTEM

⚠ WARNING

- To prevent injury, keep your hands and clothing away from the cooling fan. It may start automatically, without warning.

NOTE

- The secondary air supply system introduces filtered air into the exhaust gases in the exhaust port. The secondary air is drawn into the exhaust port whenever there is a negative pressure pulse in the exhaust system. This charged secondary air promotes burning of the unburned exhaust gases and changes a considerable amount of hydrocarbons and carbon monoxide into relatively harmless carbon dioxide and water.

Check the air supply tubes between the valve and exhaust ports for deterioration, damage, or loose connections. Make sure the tubes are not kinked, pinched, or cracked.

NOTE

- If the tubes show any signs of heat damage, inspect the reed valve in the system for damage.

Check the vacuum hose between the intake pipe and valve for deterioration, damage or a loose connection. Make sure the hose is not kinked, pinched, or cracked.

Refer to the vacuum hose routing diagram label for hose connections.

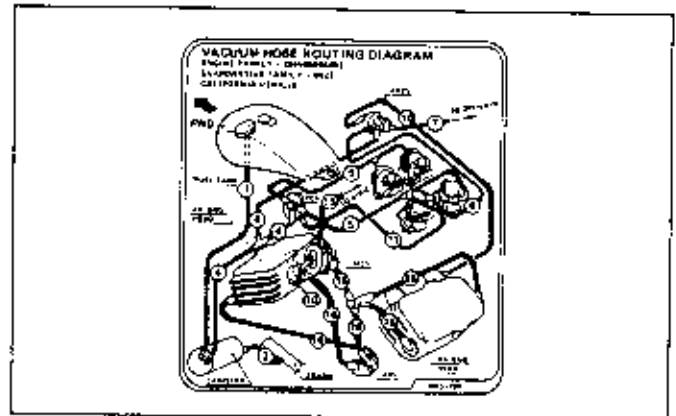

EVAPORATIVE EMISSION CONTROL SYSTEM

⚠ WARNING

- To prevent injury, keep your hands and clothing away from the cooling fan. It may start automatically, without warning.

NOTE

- Fuel vapor from the fuel tank is directed into the charcoal canister while the engine is stopped. When the engine is running, the purge control valve opens and fuel vapor in the charcoal canister is drawn into the engine through the carburetor. The tubes deteriorate naturally due to wear and time. Check the condition of these tubes at the intervals specified in the Model Specific manual.

Check the hoses between the fuel tank, canister, purge control valve (PCV), air vent control valve and carburetors for deterioration, damage or loose connections.

Check the charcoal canister for cracks or other damage. Refer to the vacuum routing diagram label for hose connections.

VEHICLE EMISSION CONTROL INFORMATION UPDATE HONDA MOTOR CO., LTD.

THIS VEHICLE HAS BEEN ADJUSTED TO
IMPROVE EMISSION CONTROL PERFORMANCE
WHEN OPERATED AT HIGH ALTITUDE.



ALTITUDE PERFORMANCE ADJUSTMENT INSTRUCTIONS
ARE AVAILABLE AT YOUR AUTHORIZED HONDA DEALER.

TRANSMISSION OIL (2-stroke engine)

Check for oil leakage over all sections of the transmission.
Check the oil level.

Excessive oil leakage necessitates disassembly.

With the engine stopped, remove the oil check bolt and make sure that the oil level is up to the lower edge of the bolt hole. Refill to the lower edge of the oil level check bolt hole with the recommended oil if the level is low.

NOTE

- Oil level checks should be carried out on level ground with the vehicle on the center stand or while in an upright position.

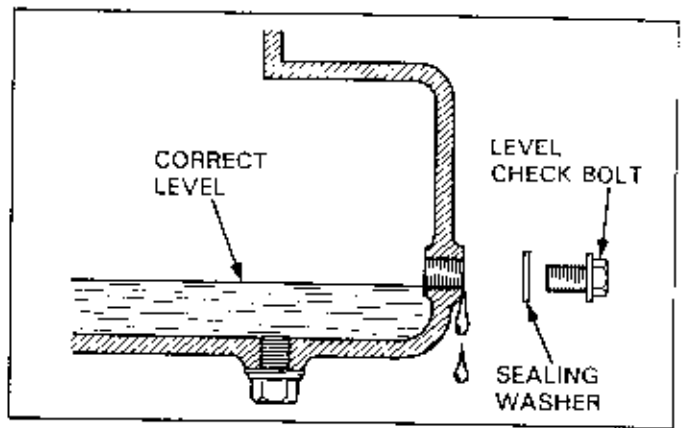

In scooters, check for leakage and oil level of the final reduction gear case in the same way as for the engine.

Remove the level hole cap from the gear case and check whether the oil level comes up to lower edge of the hole. If the level is low, refill to the lower edge of the hole with the recommended oil.

NOTE

- Oil level checks should be carried out on level ground with the vehicle on the center stand or while in an upright position.

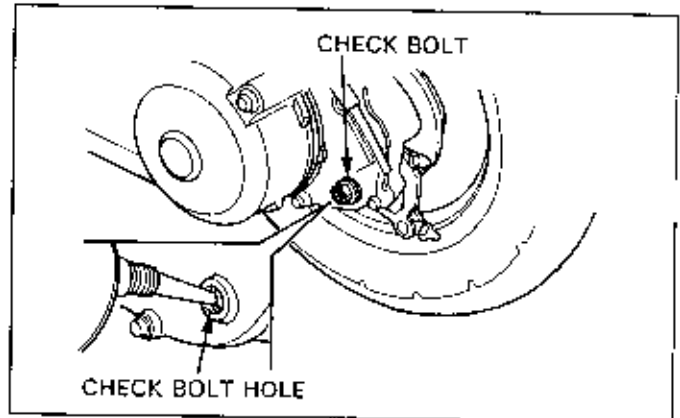

Transmission oil change

Two stroke engine transmission lubrication is achieved by the spray of transmission oil within the sealed crankcase. Compared to 4 stroke engines, there is little oil degradation, and the period for change is longer.

Consult the Model Specific manual for the proper oil change interval.

⚠ WARNING

- Used engine oil may cause skin cancer if repeatedly left in contact with the skin for prolonged periods. Although this is unlikely unless you handle used oil on a daily basis, it is still advisable to wash your hands with soap as soon as possible after handling used oil.

NOTE

- Oil is more easily drained when the engine is warm.

Remove the oil filler cap.

Remove the drain bolt located at the bottom of the crankcase and drain the oil.

When all the oil is drained, clean the drain bolt with its sealing washer and tighten to the designated torque.

NOTE

- Be sure to replace the sealing washer if it is damaged.

Remove the oil check bolt, and refill to the prescribed level with the recommended oil. Replace the check bolt or cap.

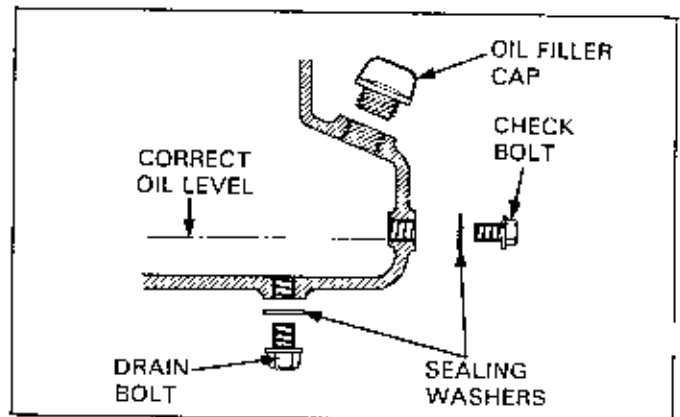

DRIVE CHAIN

ADJUSTMENT

⚠ WARNING

- Inspecting the drive chain while the engine is running can result in serious hand or finger injury.

When there is too little slack, a change in the distance between sprocket centers, due to suspension movement, results in excessive tension on the chain.

In this condition, the chain and transmission or crankcase may be damaged, and the large amount of friction adversely affects the running performance of the vehicle.

Too excessive slack in the chain leads to large oscillations when the vehicle is running.

In this condition, the chain may come off the sprockets or damage parts it contacts.

With the vehicle in neutral, support on the center or side stand. (Some models need to be checked with the rear wheel raised. Refer to the Model Specific service manual for details). Check the slack in the chain at the mid point between the two sprockets.

(On models with a chain tensioner, loosen the tensioner before checking).

Carry out the following procedure for adjustment:

Loosen the rear axle nut until the wheel can be moved.

Loosen the adjuster lock nut, turn the adjuster nut or bolt and adjust the play.

On snail cam types, rotate the adjuster plates.

A scale is included on the adjuster. Be sure that the reading on the scale is the same for both sides.

CAUTION

- If the adjustment value is not the same, the wheel is out of alignment and can cause excessive tire, sprocket and chain wear.

As the rear suspension moves through its travel, the distance between the drive and driven sprocket centers varies. Therefore, it is important to adjust the chain so that it has at least the minimum amount of acceptable slack when the sprockets are farthest apart—or when the center of the drive sprocket, swingarm pivot bolt and the rear axle are in alignment. The Model Specific manual provides a proper dimension for each model based on this minimum slack and maximum distance position, but it is measured in a much more convenient suspension position.

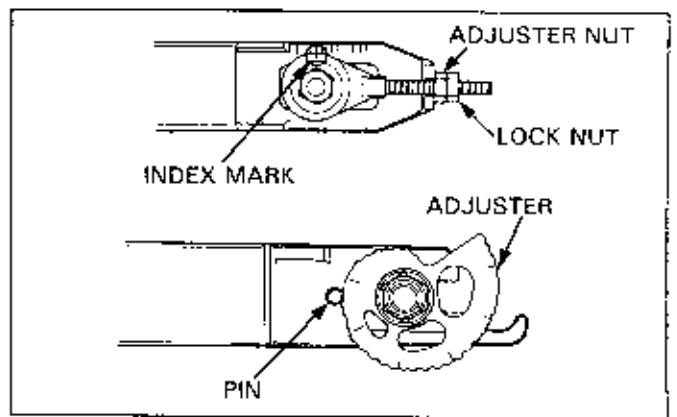
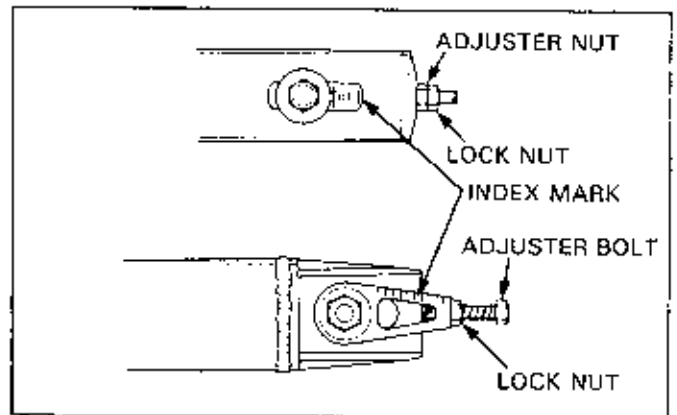
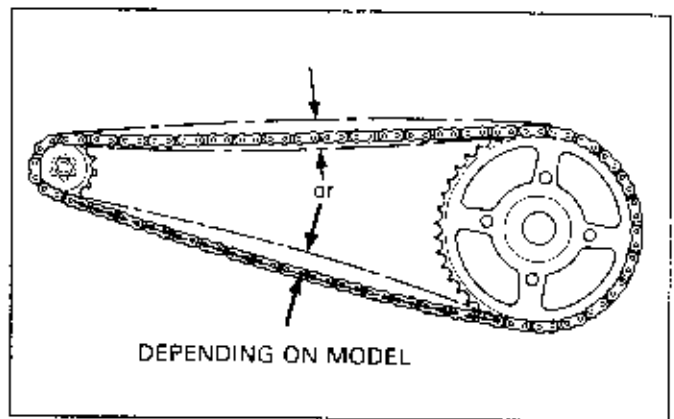

MAINTENANCE

After adjustment, retighten the axle nut to the specified torque.

NOTE

- Pulling the lower chain row firmly up toward the swing-arm when tightening the axle nut helps ensure that the adjusters on both sides are seated against their stops and that the axle is in proper alignment. Always check to be sure both sides are adjusted to the same marks on the adjustment scales.

Re-check the chain play.

Tighten the adjusters and lock nuts.

Adjust the rear brake pedal play. (This step can be omitted in the case of disc brakes).

Adjust the rear brake light switch actuation point (on cable operated rear drum brake models).

If, after adjustment, the adjuster's alignment mark is within the red zone of the chain wear indicator label, replace the drive chain and both sprockets (Only for vehicles with an indicator label affixed).

NOTE

- Always replace both sprockets when replacing the drive chain for optimum wear characteristics.

After replacing and adjusting the drive chain, attach a wear indicator label so that the alignment mark is at the start of the green zone.

On models without a drive chain wear indicators measure the length between the chain's pins as shown in the figure and replace the chain if the prescribed limits are exceeded.

Drive chain length (41 pins, 40 links).

CHAIN SIZE CODE	PITCH		STANDARD mm (in)	SERVICE LIMIT mm (in)
	mm	in		
415-420-428	12.70	0.500	508 (20.0)	511 (20.1)
520-525-50	15.875	0.625	635 (24.0)	638 (25.1)
630	19.05	0.750	762 (30.0)	766 (30.2)

Some endless chains require removal of the swingarm for drive chain replacement.

Others use a special tool to remove and install the master link.

The outer plate of this type of master link is secured by expanding the ends of the pins with the special tool.

Position the masterlink clip so that its open end is opposite the normal rotation of the chain. This prevents the clip being knocked off through contact with the chain guide or passing objects. Check that the clip is fully seated.

CAUTION

- Improper positioning of the masterlink may cause the drive chain to come apart and possibly damage the crankcase, rear wheel or exhaust.

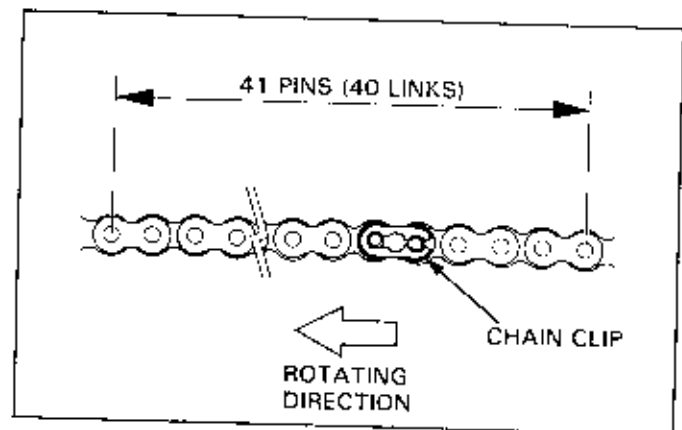
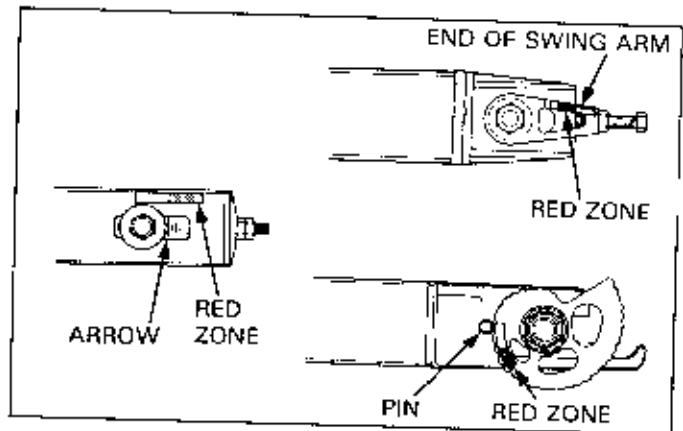
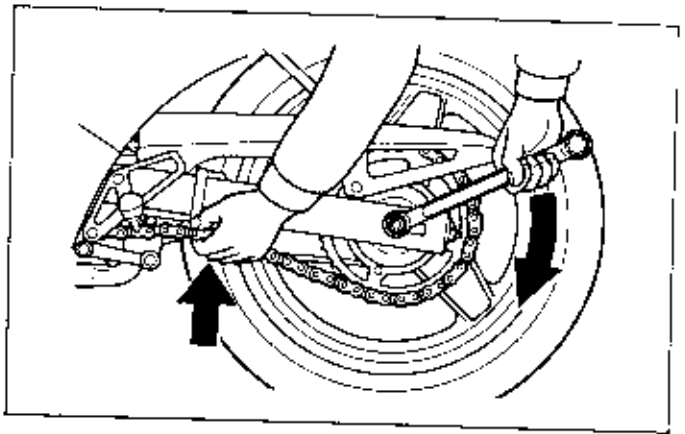

Check that each chain link pivots freely on the pins. Where binding is light, apply a little cleaning oil or paraffina making sure that it penetrates. When the stiffness has been removed, lubricate the chain. On chains with O-ring, quickly wipe off the cleaning fluid or paraffin oil, and thoroughly dry the chain. Replace the chain if stiffness of the chain cannot be alleviated, the movement of the links is not smooth, or there is damage to the link plates or rollers. Master links with O-rings have 4 O-rings fitted between rollers and master link plates. Install the O-rings as shown in the illustration to the right and fit the chain clip to the pins. Be sure there is no gap between the master link plate and the clip.

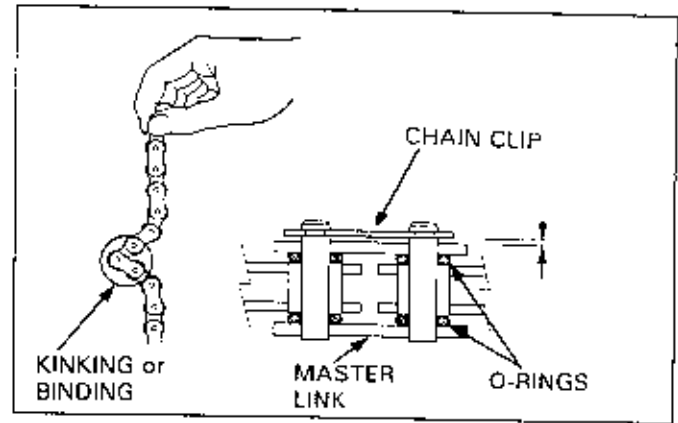

Cleaning and Lubrication

Adherence of mud and dirt, and lack of lubrication severely shortens the life of the chain. Cleaning and lubrication should therefore be carried out periodically.

[Chains with O-rings]

CAUTION

- Chains with O-rings should not be treated to the following cleaning and oiling procedure. This treatment will cause degradation of the O-rings and loss of grease, thus shortening chain life.
- Do not use steam or a high pressure water washing. Use a chain spray containing a cleaning agent or use gasoline to clean the chain.

Clean dirt off the chain with suitable detergent, dry completely and thoroughly, and apply #80-90 gear oil.

Wipe off excess oil to prevent it from flinging off when in operation.

[Chains without O-rings]

Remove dirt from the chain with cleaning oil or paraffin, dry completely and thoroughly, and apply #80-90 gear oil or a suitable spray-on chain lubricant.

Wipe off the excess oil to prevent it from flinging off when in operation.

Check for wear and damage to the drive and driven sprockets.

CAUTION

- Be sure to replace the chain and sprockets as a set. The combination of an elongated chain and new sprocket(s) or the combination of a worn sprocket(s) and a new chain will result in rapid wear of the new component(s).

Check for looseness of the attachment bolts or nuts on the drive and driven sprockets, and if loose, re-tighten.

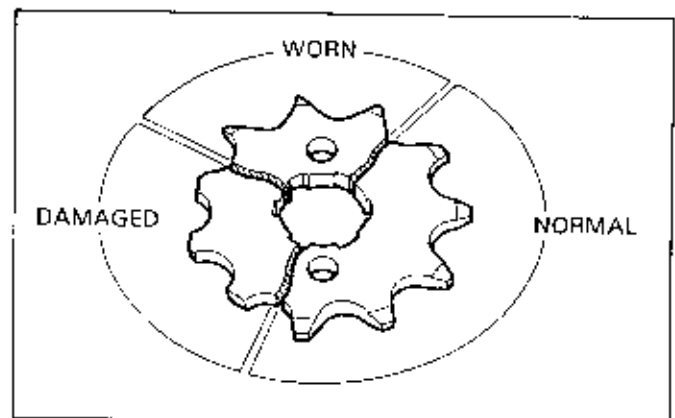
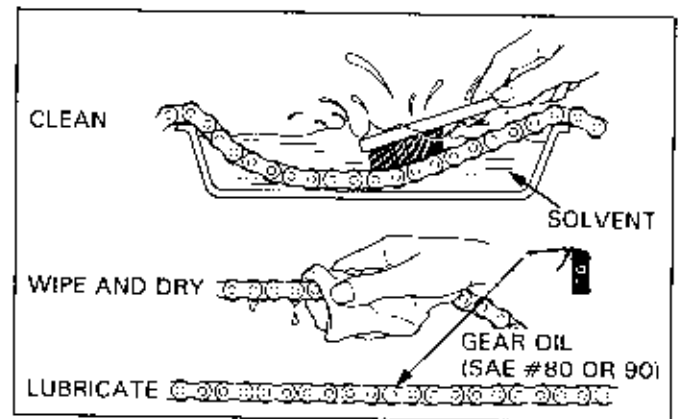
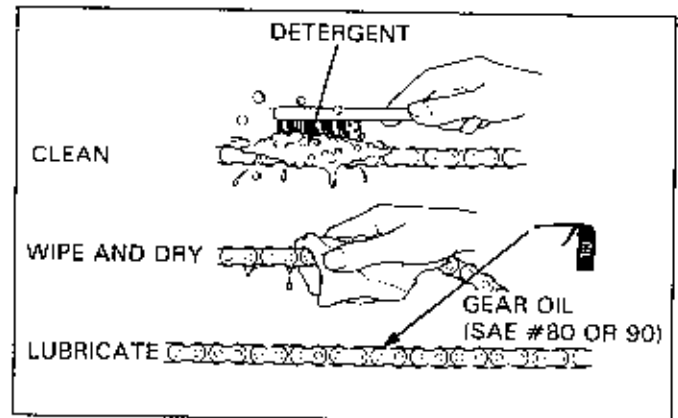

DRIVE CHAIN SLIDER, CHAIN GUIDE, GUIDE SLIDER AND ROLLERS

Together, the drive chain slider, chain guide, guide slider and rollers all do their part to keep the chain running in its proper path, while preventing it from cutting into the swingarm, frame or other components.

Each of these components is made of a type of plastic that offers minimal friction and wear. Still, periodic inspection for wear or damage and replacement is necessary as these parts deteriorate.

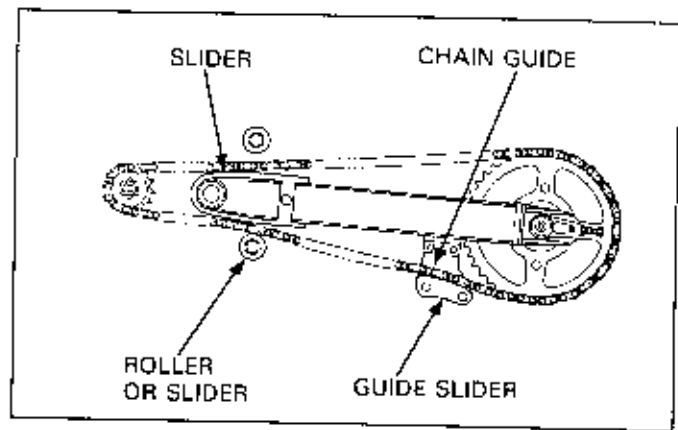

The chain slider, attached to the front of the swingarm near its pivot point, must be replaced when the depth of its wear grooves reaches a depth specified for each particular model. Failure to replace a worn slider will result in chain damage to the swingarm and damage to the chain.

Off-road and dual-purpose motorcycles are fitted with a chain guide that ensures that the chain is guided directly to rear sprocket. The guide itself should be checked for proper alignment as it can be bent through contact with passing objects, rocks or crash damage. Straighten or replace as necessary. A plastic guide slider centers the guide on the sprocket with minimal friction and prevents the chain from wearing the guide. A wear window is often provided to aid in determining a replacement time.

A lower chain roller, or a pair of upper and lower rollers are used to take up excess slack in the drive chain as the rear suspension compresses and extends to its furthest points. These rollers also help prevent the chain from cutting into other components on the motorcycle, like the airbox or exhaust on some motorcycles, when the suspension is near or fully compressed. These must also be periodically inspected for wear, damage and security of mounting.

DRIVE BELT

A drive belt is used on the Honda V-matic belt automatic transmission.

The belt must be checked periodically according to the maintenance schedule shown in the Model Specific manual.

A worn or damaged drive belt may cause a loss in scooter performance.

Remove the drive belt cover (see the Model Specific manual) and check the drive belt for wear, cracks or peeling of the cogs or plias; replace with a new one if necessary.

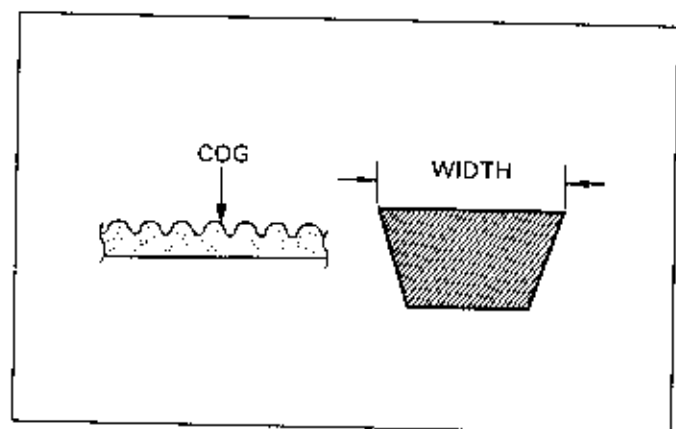

BELT CASE AIR CLEANER

On scooters with a cleaner element in the air inlet to the drive belt case, remove the element and clean.

Wash the element in water and dry it thoroughly before reinstalling.

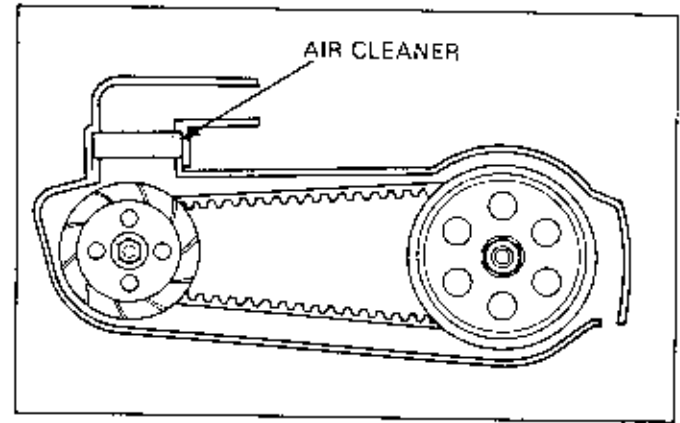

FINAL DRIVE OIL LEVEL

Check for leakage and proper oil level.

Remove the inspection/level hole cap from the gear case and check that the oil level is up to the lower edge of the hole. If the oil level is low, refill to the lower edge of the hole with the recommended oil.

NOTE

- Oil level checks should be carried out on level ground with the vehicle on the center stand.

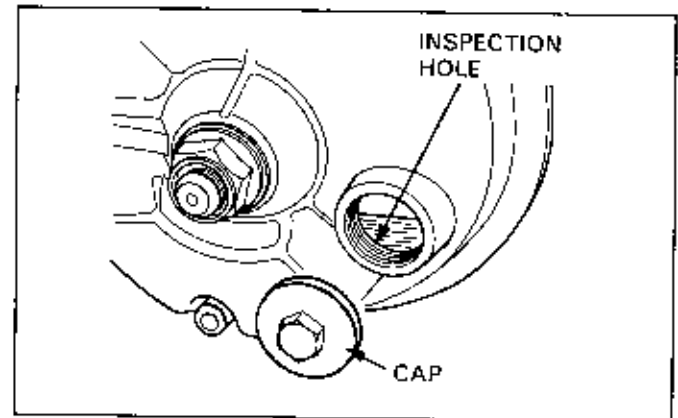

OIL CHANGE

Refer to the Model Specific service manual for information on the oil change interval.

Remove the level hole cap from the final gear case.

Remove the oil drain bolt from the lower portion of the gear case, slowly turn the rear wheel and drain the oil. When the oil is completely drained, clean the drain bolt, replace the sealing washer and tighten to the specified torque.

NOTE

- Replace the sealing washer if it is damaged.

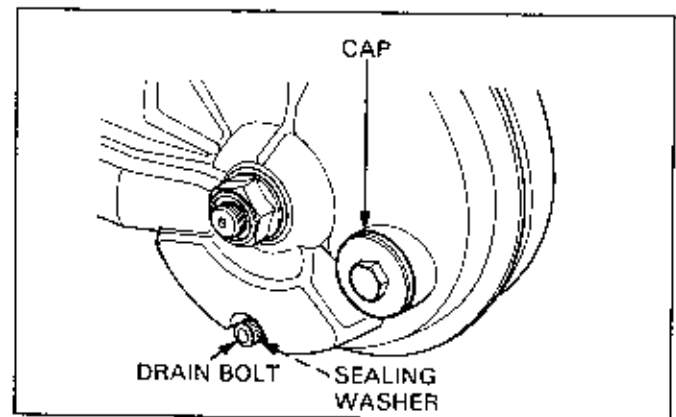

Refill to the prescribed level with the recommended oil.

Coat the level hole cap O-ring with oil and replace the cap.

Tighten the cap to the specified torque.

MAINTENANCE

BATTERY

Fluid level

Battery fluid level checks are unnecessary on MF (Maintenance Free) batteries.

Open type batteries should be checked for fluid level.

⚠ WARNING

- Do not allow battery fluid (sulphuric acid) to come into contact with the skin, eyes or clothes as it will cause burning. If acid is spilled on you, be sure to wash off quickly with large amounts of water. If battery fluid enters the eyes, wash with water and consult a physician.

Check for cracks in the battery case.

If the battery's electrodes show accumulation of a white substance (sulphation) or heavy deposits are observed at the base of the battery, the battery should be replaced.

Check the level of each cell by the UPPER and LOWER level lines inscribed on the side of the battery.

If levels are approaching the LOWER level line, remove the battery, take off the filler caps and refill to the UPPER level with distilled water.

Check the battery capacity with a battery tester (page 22-9). If the battery tester is not available, check the gravity of the battery fluid (see below).

CAUTION

- Always refill batteries with distilled water. Tap water contains minerals that will shorten the life of the battery.
- Filling the battery above the UPPER level mark may cause spillage while riding and subsequent corrosion of vehicle parts.

After refilling, replace each of the filler caps firmly and re-install the battery.

Follow the instructions on the battery's CAUTION label. Make sure that the breather tube is correctly positioned, and not kinked, trapped or bent in such a way as to obstruct the passage of air.

CAUTION

- If the tube is blocked, the battery's internal pressure will not be relieved, the breather may come off, or the battery could crack as a result.

Specific gravity of fluid

Checks are unnecessary in the case of MF (Maintenance Free) batteries.

The specific gravity of the battery fluid should be checked on open type batteries.

Measure the specific gravity of each cell with a hydrometer.

Specific gravity of fluid at 20°C (68°F)

Fully charged condition 1.27–1.29

Low charge condition 1.23 and below

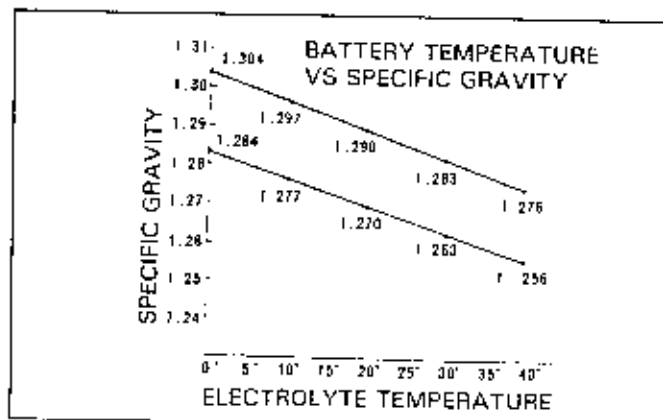
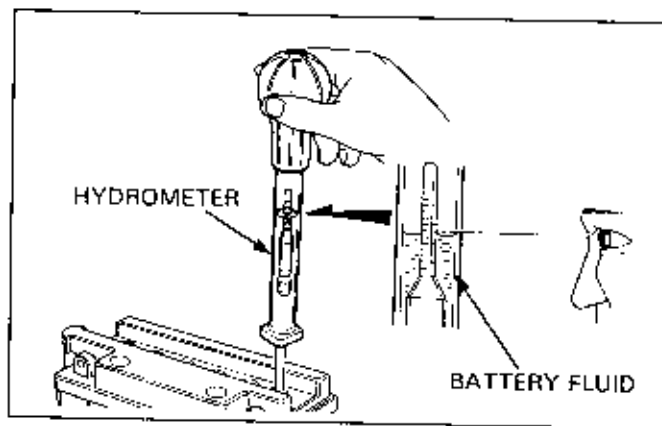
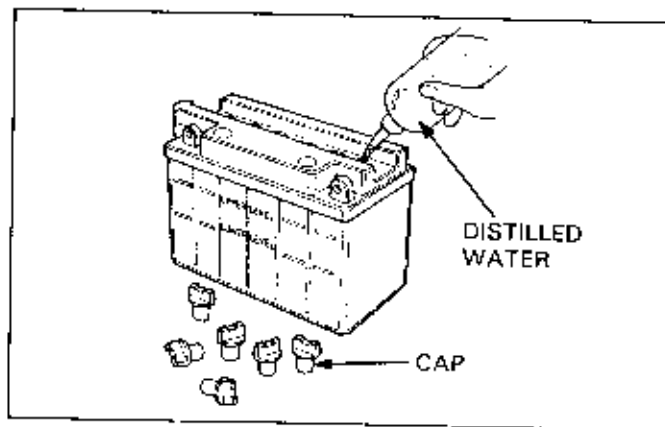
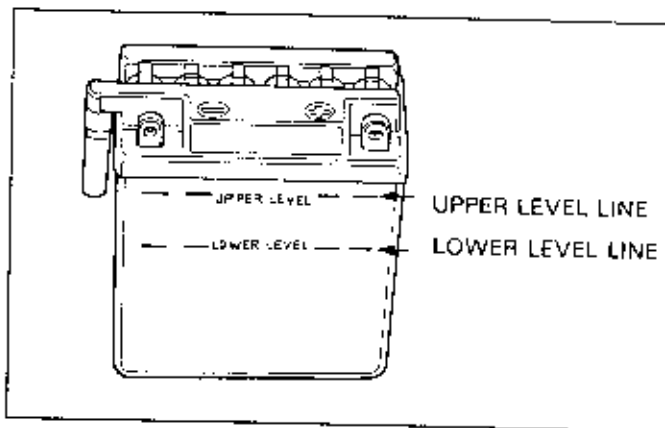

NOTE

- If the difference in specific gravity between cells exceeds 0.01, re-charge the battery. If the difference in specific gravity is excessive, replace the battery.
- There is a change in specific gravity of approximately 0.007 per 10°C change in temperature. Be sure to consider this when taking measurements.
- Reading of the hydrometer's fluid level should be taken in the horizontal position.

Refer to section 22 for details of battery testing and charging.

Condition of terminal connections

Make sure that terminal connections are not loose. If corrosion is evident, remove the battery, wash rust with warm water and use a wire brush to remove completely.

Reconnect the battery and lightly coat the terminals with grease.

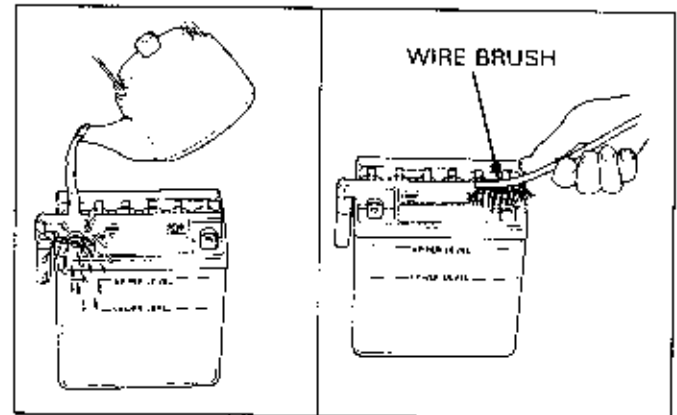

BRAKE FLUID

Firmly apply the brake and check for fluid leakage from the brake system. If there is any leakage of fluid from any part of the system, quickly replace the damaged parts.

Check for degradation and damage of the hoses, pipes and joints. Check for looseness of joints and clamps. Also make sure that hoses and pipes do not come into contact with mechanical parts when the fork is turned, or due to vibration when the vehicle is running.

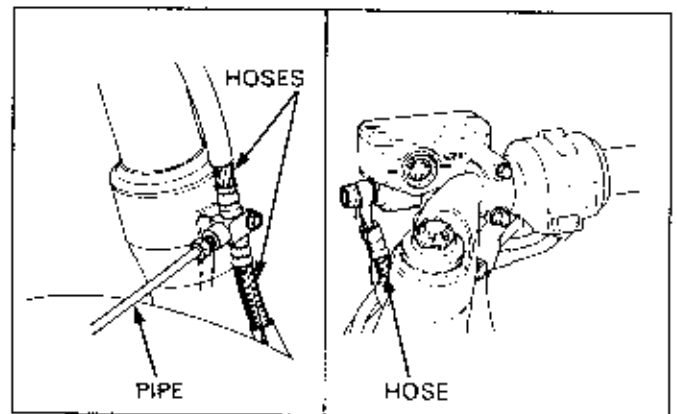

Before removing the reservoir cover, turn the handlebar until the reservoir is level.

Place a rag over painted, plastic or rubber parts whenever the system is serviced.

CAUTION

- Brake fluid will damage painted, plastic or rubber parts.

Refill with the recommended fluid.

WARNING

- Mixing incompatible fluids can impair braking efficiency.
- Foreign materials can clog the system, causing a reduction or complete loss of braking ability.

MAINTENANCE

When the fluid level is low (i.e. near the LOWER level inscribed on the reservoir) remove the reservoir cover and diaphragm, and refill to the UPPER level.

Check the brake pads for wear when refilling with brake fluid. A low fluid level may be due to wear of the brake pads. If the pads are worn, the caliper piston is pushed out, and this accounts for a low reservoir level.

If the brake pads are not worn and the fluid level is low, check for leakage.

⚠ WARNING

- A leak in the brake system can lead to reduced braking efficiency and possible loss of braking ability.
- The recommended brake fluid differs according to models. Certain models take DOT 4, and others take either DOT 3 or DOT 4. Do not use DOT 3 standard brake fluid in a model designated for DOT 4, brake failure may result.

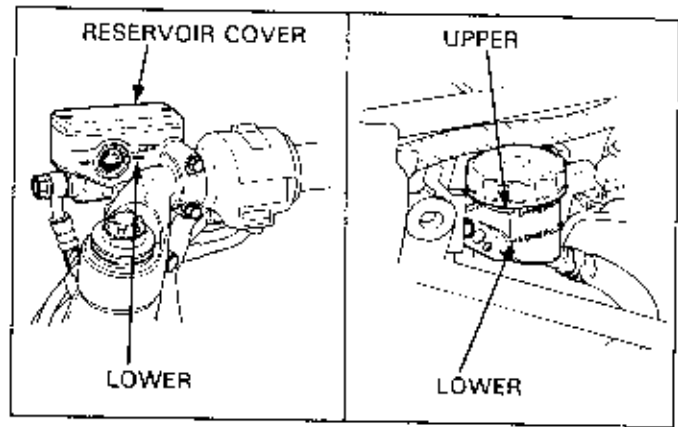

BRAKE SHOE WEAR

If the wear indicator arrow aligns with the "Δ" mark on the brake panel when the brake is applied, remove the wheel and brake panel and check for shoe wear.

NOTE

- If no adjustment remains before the wear indicator limit is reached, this indicates excessive wear and the brake shoes need to be replaced.

Specific brake shoe checks are listed in the Brakes section of the manual.

Inspect the brake drum for wear or damage any time you remove the wheel and brake panel.

If the brake drum shows any signs of cracking or excessive corrosion that cannot be removed with emery cloth, be sure to replace it.

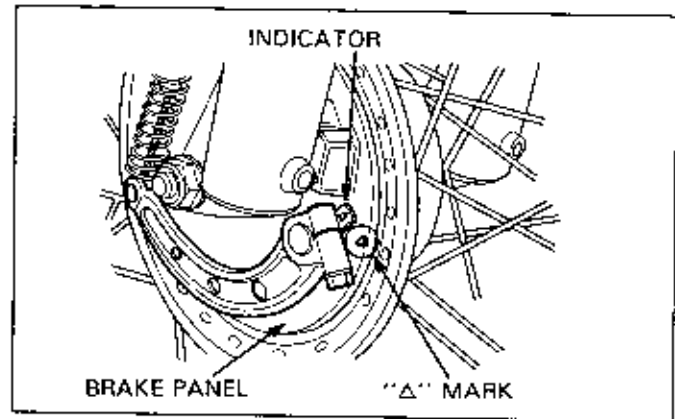

BRAKE PAD WEAR

Replace pads as a set if worn to the brake pad wear limit line (or wear limit groove).

A quick visual inspection can be made at the leading edge of the pads (where the disc enters the caliper).

However, if this proves difficult, a check can be made at the indicator on the caliper marked by the arrow (▲).

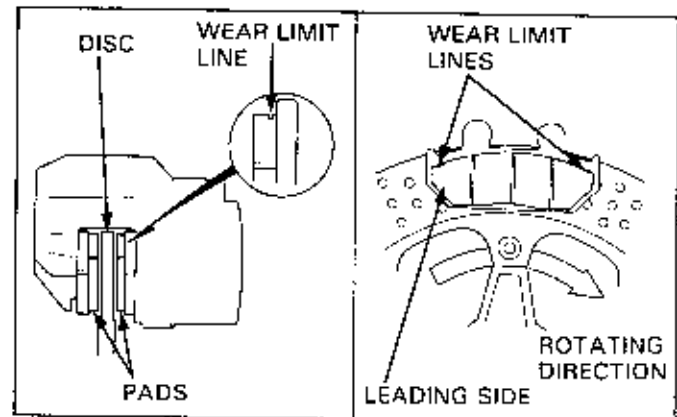

BRAKE SYSTEM

INSPECTION FOR AIR IN SYSTEM

On hydraulic brakes, firmly apply the brake lever or pedal, and check that no air has entered the system. If the lever or pedal feels soft or spongy when operated, bleed the air from the system.

FREE PLAY ADJUSTMENT

On mechanical brakes, measure the free play at the tip of the brake lever or pedal as indicated here and below.

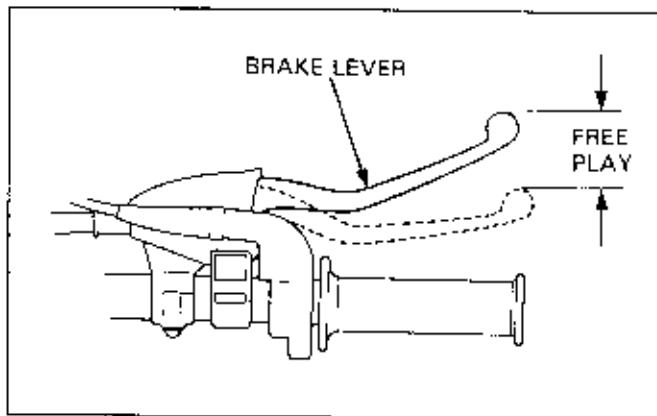

Brake pedals on scooters should be measured for free play as indicated here.

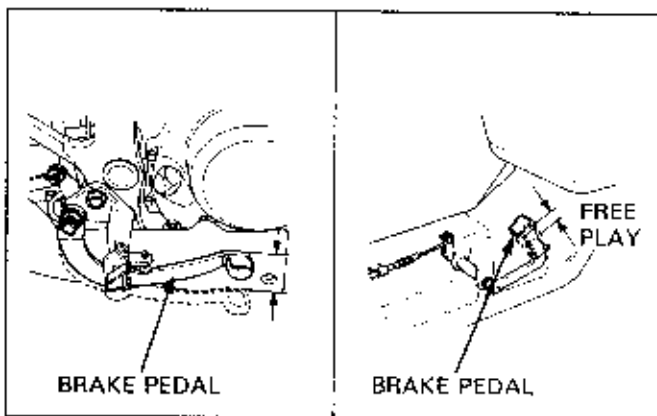

Make adjustments for free play on cable-operated brakes at the end of the cable.

Major adjustments are made on the brake panel end of the cable.

Loosen the lock nut and turn the adjuster nut to correct play at the lever.

NOTE

- If the upper adjuster (on the lever) is screwed in most, but not all the way before adjustment is carried out, subsequent adjustment by use of the upper adjuster can be conducted more easily.
- When the brake cable is fastened to the fork by a clamp, loosen the clamp before making brake adjustments.

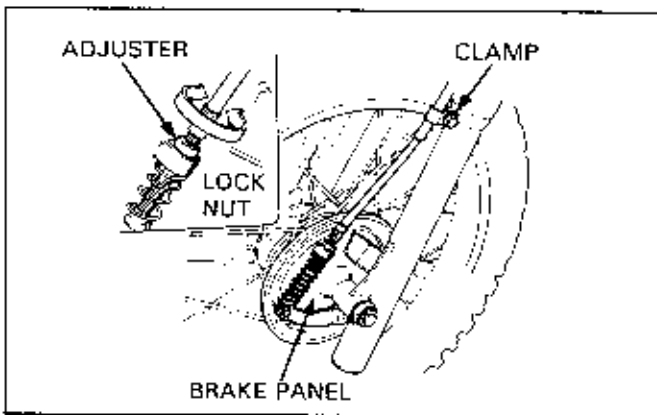

Secure the adjuster nut and tighten the lock nut on completion of adjustment. Be certain to tighten the fork cable clamp as well.

In cases where there is only an adjuster nut, as on many rear brakes, turn the nut to adjust the brake pedal free play.

NOTE

- The adjuster nut's indentation and brake arm pin should seat against one another as shown here in the upper right portion of the illustration to the right. If they do not seat, there may be a change in brake play when the adjuster finally seats in its proper position.

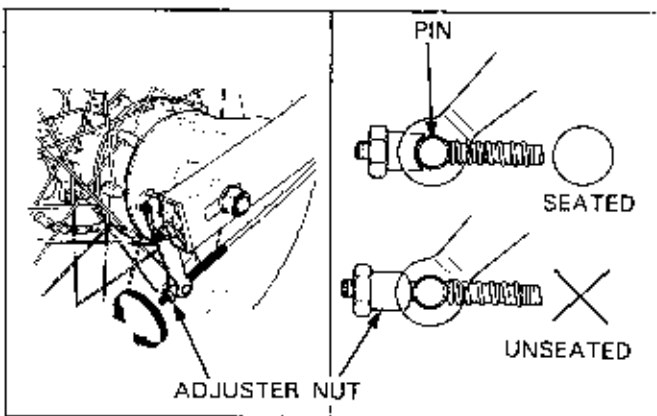

Check for play after adjustment.

MAINTENANCE

Minor adjustment is made at the lever end of the cable. It is necessary to turn back the lever dust boot to gain access to the adjuster.

NOTE

- There may be damage to the adjuster if it is positioned too far out, leaving minimal thread engagement. When there is more than 8 mm of threads showing, screw in the adjuster most, but not all the way and make adjustments on the brake panel end of the cable.

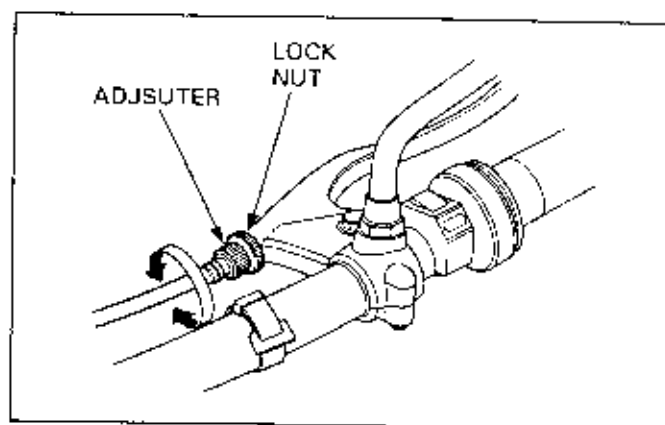

Check for looseness of the following:

- Brake lever and pedal fasteners and adjuster lock nuts
- Brake torque rod fasteners
- Brake rod, cable (mechanically operated drum brake)
- Brake arm (mechanical linkage drum brake)
- Caliper attachment bolt (hydraulic disc brake)

Check that the cotter pins on the brake rod, torque rod etc. are securely in place.

Operate brakes independently while riding in order to determine the effectiveness of each brake.

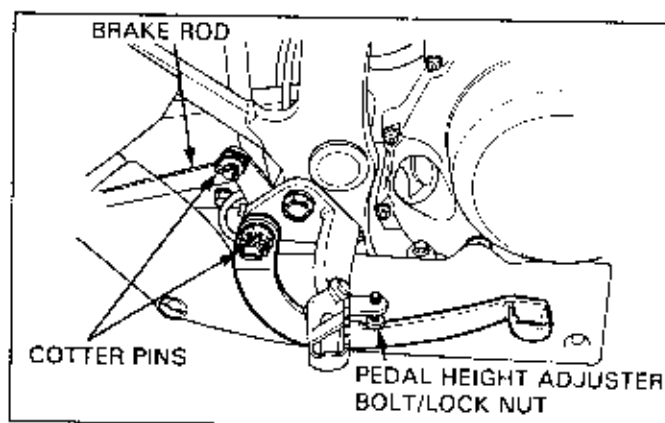

BRAKE LIGHT SWITCHES

Check the brake light switch operation and adjustment by applying the brakes. Visually inspect for any damage and make sure the reflector plate is clean within the light.

Adjust the rear brake light switch so that the brake light comes on just prior to the brake actually being engaged. If the light fails to come on, adjust the switch so that the light comes on at the proper time.

NOTE

- The brake light switch on the front brake lever cannot be adjusted. If the front brake light switch actuation and brake engagement are off, either replace the switch unit or the malfunctioning parts of the system.
- Make all rear brake light switch adjustments after the height adjustment and the brake pedal free play adjustment have been made.

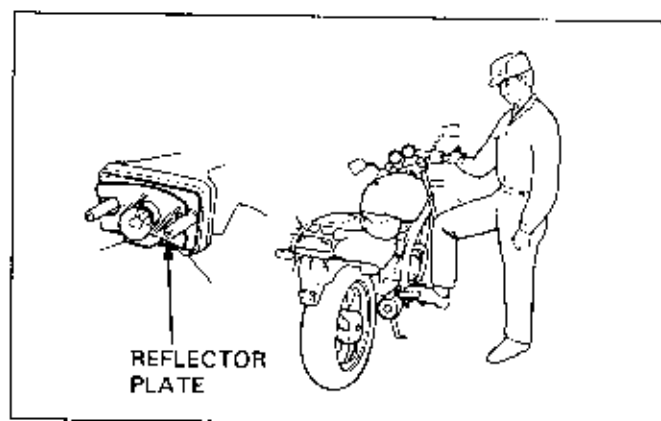

Turn the adjusting nut on the brake light switch and not the switch body and wires to make switch actuation adjustments.

Be sure to hold the switch body firmly while turning the adjusting nut.

CAUTION

- Allowing the switch body to turn during adjustment can break the wires in the switch.

After adjustment, recheck to be sure the brake light comes on at the proper time.

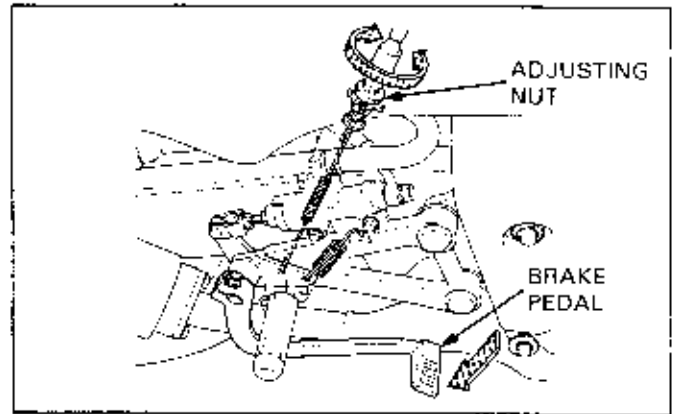

HEADLIGHT AIM

To make a vertical adjustment, loosen the headlight mounting bolts, matching the punch mark on the case and the bracket by moving the headlight up or down. Some motorcycles have an adjusting screw on the bottom of the headlight. In this case, turn the screw to make the vertical adjustment.

For those having an adjusting screw on the side of headlight rim, turn this screw to make the horizontal adjustment.

On some models the headlight is completely encased. The adjustment can be made either with the light beam adjustment knob on the back of the light case or with a remote-type cable and knob. Refer to the Model Specific manual for the proper adjustment method.

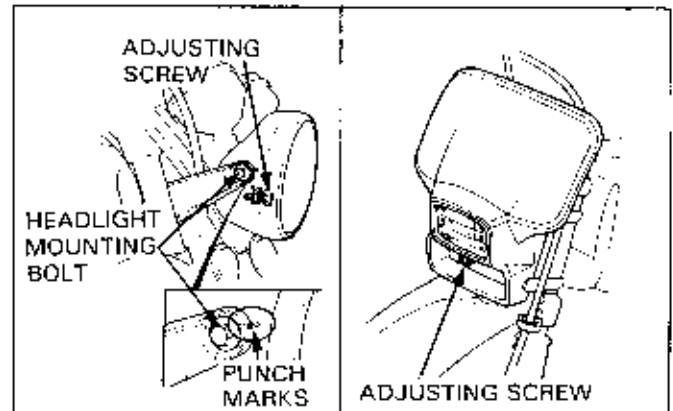

CLUTCH SYSTEM

Check the play at the end of the lever on cable operated clutches. A lot of play results in clutch drag and stiffness in operation of the shift pedal.

Too little play, however, results in clutch slippage.

When the clutch play is not adjusted within the prescribed amount, correct this using the adjuster located at the end of the cable.

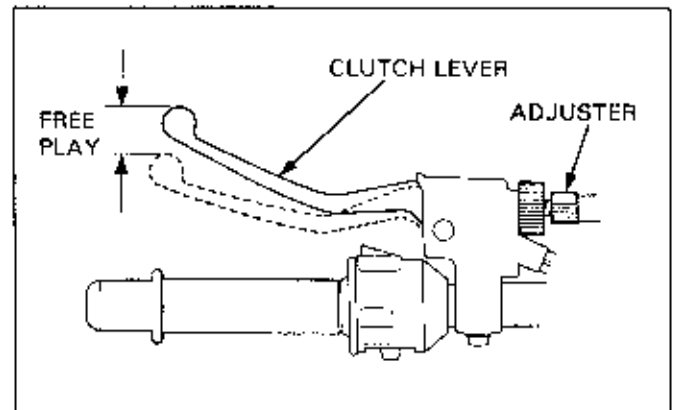

Major adjustment is carried out at the clutch arm. Loosen the lock nut and turn the adjuster nut to adjust play.

NOTE

- Before adjusting cable play at the clutch arm, screw the adjuster at the lever end of the cable in most, but not all the way. This makes subsequent adjustment at the lever end easier.

After adjustment is complete, hold the adjuster nut securely while tightening lock nut.

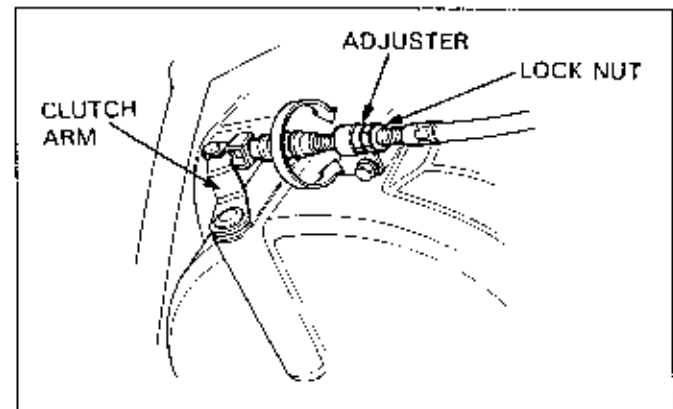

MAINTENANCE

Minor adjustments are made at the lever.

On models equipped with a dust cover, turn back the cover to allow adjustment.

Loosen the lock nut and turn the adjuster to correct the play.

CAUTION

- The adjuster may be damaged if it is positioned too far out, leaving minimal thread engagement.

When more than 8 mm of thread is showing, screw the adjuster in most, but not all the way, and make adjustments on the clutch arm end of the cable.

On models with the adjuster located within the length of the cable (i.e. not at the end), loosen the lock nut and turn the adjuster to alter the play, in the same manner as described above.

On centrifugal clutch

Loosen the lock nut, tighten the adjuster bolt by about 1 turn, then screw it back in until pressure is felt on the bolt.

From this position, loosen the bolt 1/8 to 1/4 of a turn and tighten the lock nut.

NOTE

- When tightening the lock nut, be sure that the adjuster bolt does not turn with it.
- Check the operation of the clutch after adjustment.

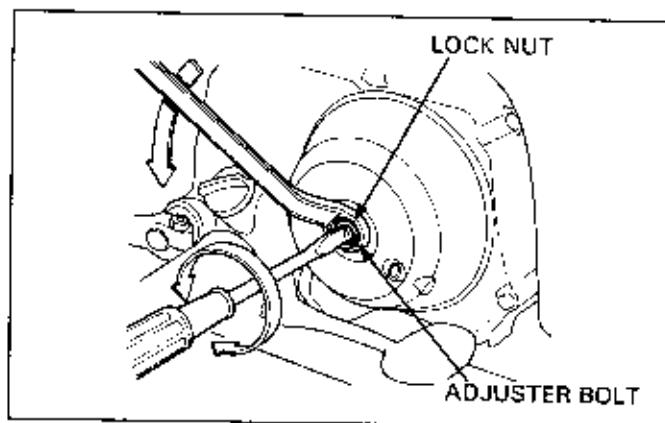
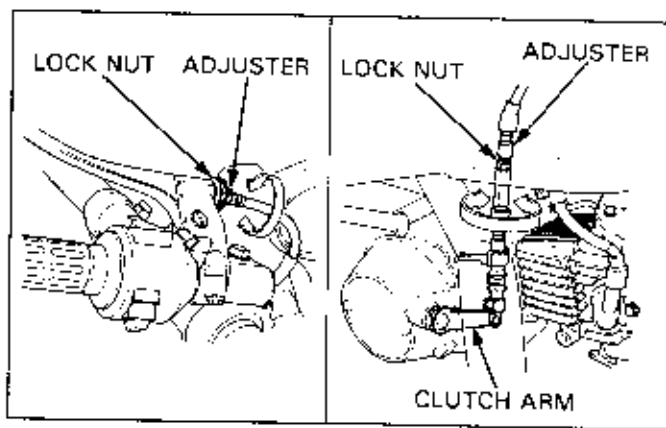

Clutch fluid level

Adjustment for play cannot be made on hydraulic clutches. However, a check should be made of the fluid level.

If the level is near the LOWER limit inscribed on the reservoir, remove the reservoir cover and diaphragm, and refill to the UPPER level with the proper type of fluid.

Before removing the reservoir cover, turn the handlebar until the reservoir is level.

Place a rag over painted, plastic or rubber parts whenever the system is serviced.

CAUTION

- Spilling fluid on painted, plastic or rubber parts will damage them.

Refill with the recommended of fluid.

CAUTION

- Mixing incompatible fluids can impair clutch operating efficiency.
- Foreign materials can clog the system, causing a reduction or complete loss of clutch ability.

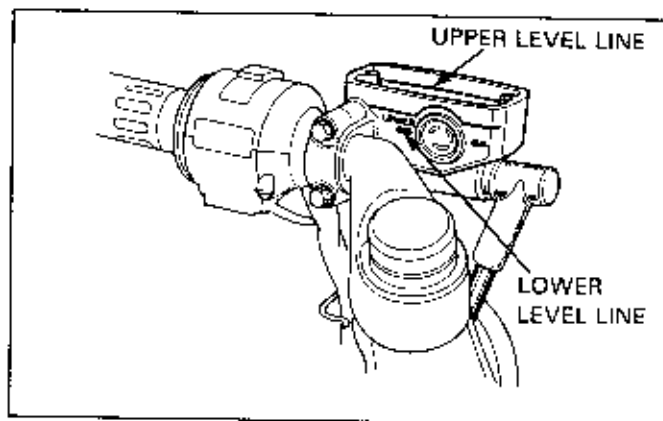

SIDE STAND

Conventional Type

Check the wear of the side stand rubber.

Replace it if it has become worn.

Support the motorcycle in an upright and level position, using a support luse (the center stand if available).

Hook a spring scale to the end of the side stand rubber and check the load before the stand starts moving.

Acceptable load measurements for side stands:

2–3 kg (4.4–6.6 lbs) (Road-type)

3–5 kg (6.6–11.0 lbs) (On/Off Road type)

If the stand moves too easily, tighten the pivot bolt and recheck. If it still does not have the required tension measurement, replace the return spring.

See if the side stand moves smoothly and retracts fully. If not, grease the pivot.

Check the side play on the side stand.

If it is too great tighten the pivot bolt.

Recheck and if it is still too great, replace the parts as necessary.

Dual Motion Type

The side stand should lower easily to its first stop, then lock after moving farther forward to support the motorcycle as the rubber touches the ground.

When the motorcycle is lifted upright, the stand should automatically move to the first position, and retract when kicked up.

If the side stand does not move freely, disassemble it:

Remove the return spring at the retracted position. Remove the pivot bolt and remove the side stand assembly from the frame.

Check the following parts for wear or damage:

- inside of the pivot and pivot collar
- pivot dust seals

Lubricate the pivot area with clean grease and reassemble the side stand.

CAUTION

- Install the dust seal with its mark side facing in.
- Make sure that the dust seal spring is seated on the outside of the seal lips after installing the pivot collar.

Recheck the side stand movement.

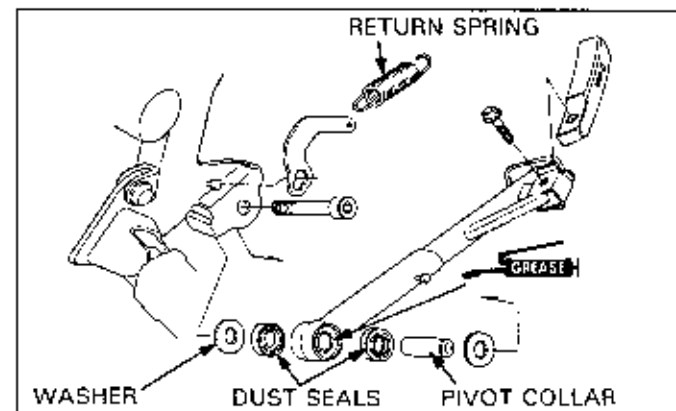
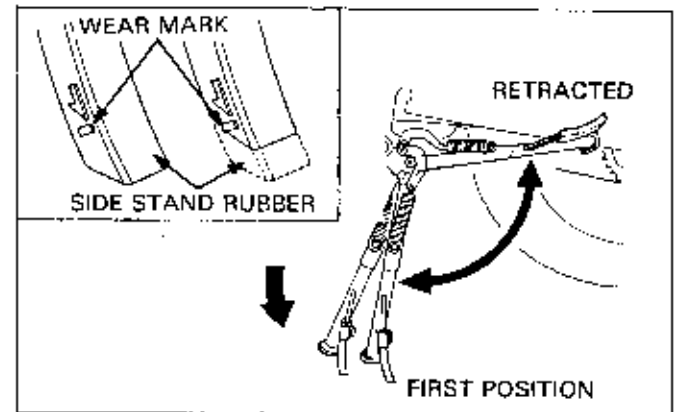
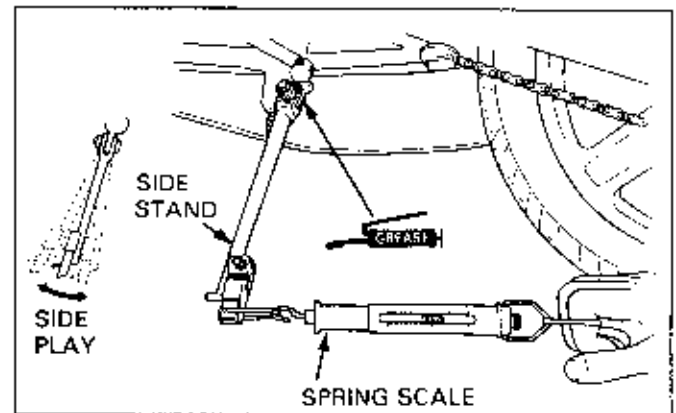
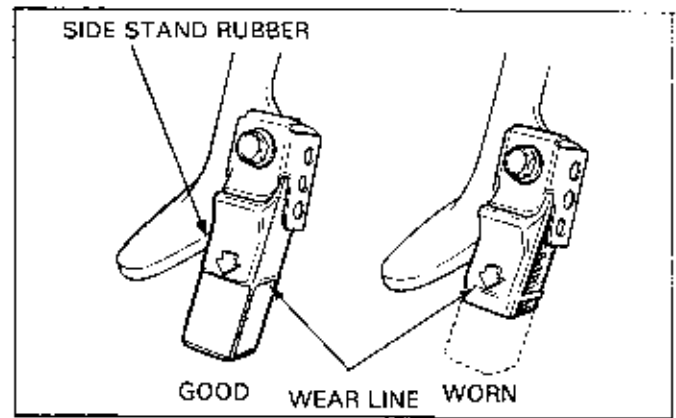

MAINTENANCE

Inspection For Side Stand With Ignition Cut-off Switch

Check the spring for damage or loss of tension.

Check the side stand assembly for freedom of movement.

Lubricate the pivot bolt and the side stand pivot area if necessary.

Tighten the pivot bolt and nut. Refer to the Model Specific manual for specified torque.

Check the side stand ignition cut-off switch:

- Sit astride the motorcycle and raise the side stand.
- Start the engine with the transmission in neutral, then shift the transmission into gear, with the clutch lever squeezed.
- Move the side stand full down.
- The engine should stop as the side stand is lowered.

If there is a problem with the system, check the side stand switch.

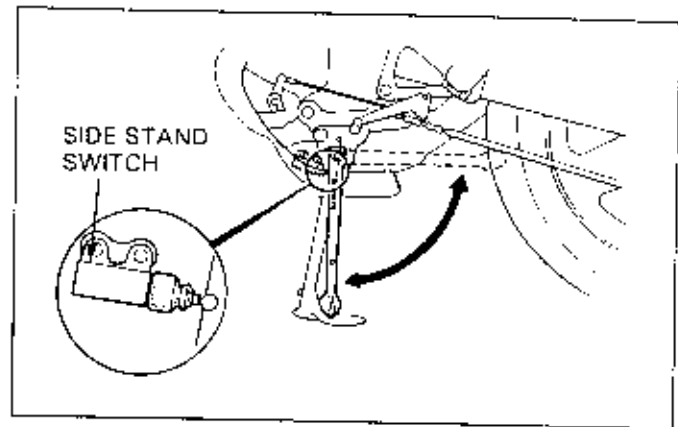

SUSPENSION

Compress the front and rear suspension a few times.

On models with exposed suspension springs, check for cracks and damage.

WARNING

- Loose, worn, or damaged suspension parts impair vehicle stability and control. Repair or replace any damaged components before riding. Riding a vehicle with faulty suspension increases your risk of an accident and possible injury.

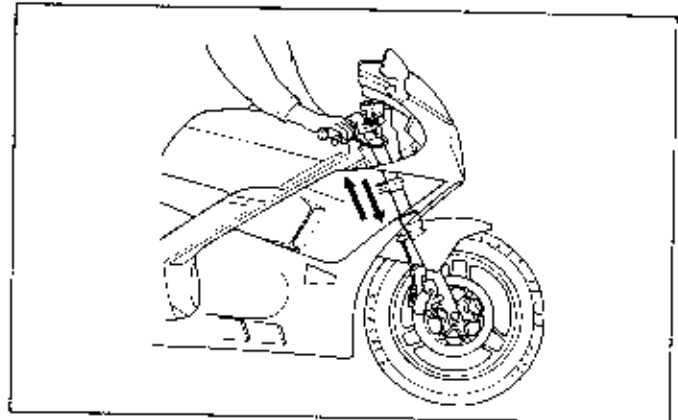

Check for squeaks in the suspension movement that could indicate a lack of lubrication. Try to push the swingarm from side to side to check for worn, damaged or loose suspension pivot components.

If any play is detected, check for looseness of the swingarm pivot bolt.

Check also for wear or damage to the pivot bearings (or bushings).

If looseness is detected in the up-down motion at the end of the arm on Pro-link suspensions, check for wear or damage to the shock absorber mount pivot point.

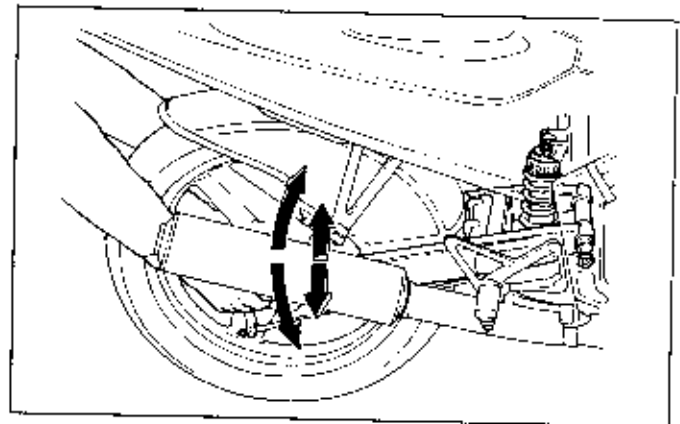

Check for leakage from the oil seals on the fork, scratch marks on the working surface of the fork tubes, and wear and peeling of the chrome plating.

On models equipped with rubber boots on the fork legs, turn back the boots to allow inspection.

If the fork is in poor condition, disassemble and replace parts as necessary.

NOTE

- Replace any fork tube that is heavily scored.

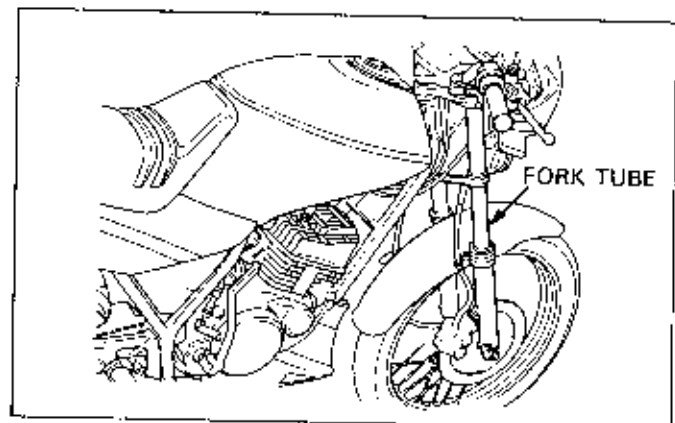

On models with bottom link type front suspension, check for cracks and damage to the fork rocker arms (bottom links). Check for play in the fork rocker arm bearing section, and inspect all fasteners for looseness.

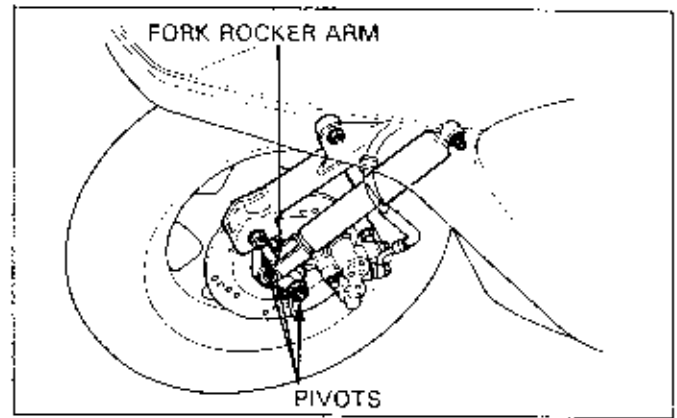

Check for oil leakage around the shock absorber piston rod. Inspect the rod for scoring, wear and peeling of the chrome plating on the working surface.

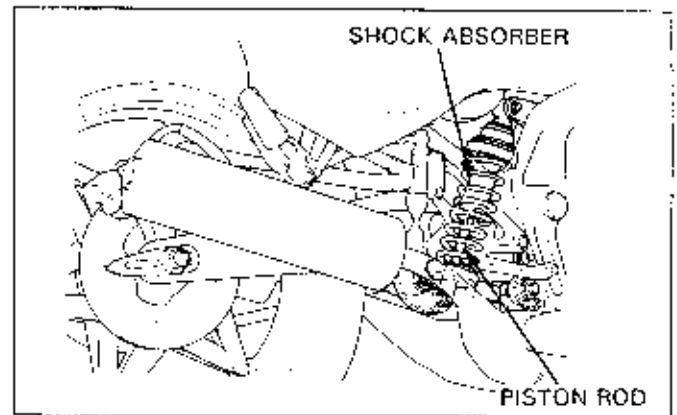

Check for looseness, cracks and damage to the attachment points of the shock absorber assembly. Re-tighten nuts/bolts if necessary.

SPARK ARRESTER (USA only)

⚠ WARNING

- Wait until the pipe has cooled before removing or installing the muffler lid. Touching the hot exhaust may result in severe burns.
- Perform this operation in a well-ventilated area free from combustible materials. Carbon particles may blow out of the clean out hole when performing this service. Wear safety glasses to prevent possible eye injuries.

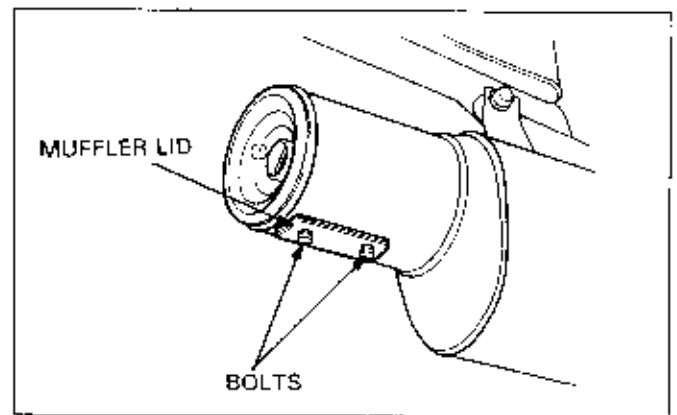

Remove the muffler lid. Block the end of the muffler with a shop towel.

Start engine and rev it up to blow accumulated carbon deposits out of the muffler.

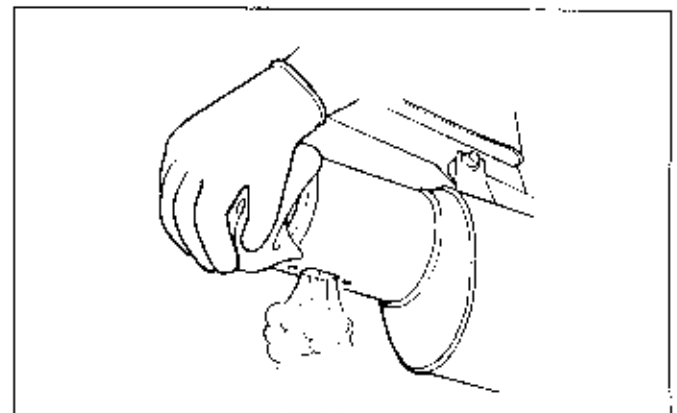

MAINTENANCE

Be sure that the muffler lid bolts and gasket are in good condition. Replace the bolts and gasket if necessary.

Install the muffler lid and gasket and tighten the bolts securely.

NOTE

- Do not remove the two screws that hold the exhaust baffle in the end of the spark arrester/muffler.
- The two mounting screws must be installed in the spark arrester body at all times for the spark arrester to be effective.

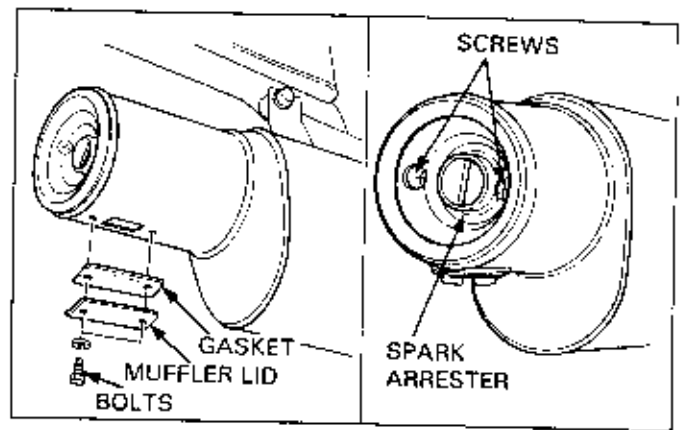

NUTS, BOLTS, FASTENERS

Check that all chassis nuts, bolts and screws are tightened to their correct torque values at the intervals shown in the Maintenance Schedule.

Check all cotter pins, slip pins, hose clamps and cable stays.

WHEELS/TIRES

Making sure the fork is not allowed to move, raise the front wheel and check for play. Turn the wheel and check that it rotates smoothly with no unusual noises.

If faults are found, inspect the wheel bearings.

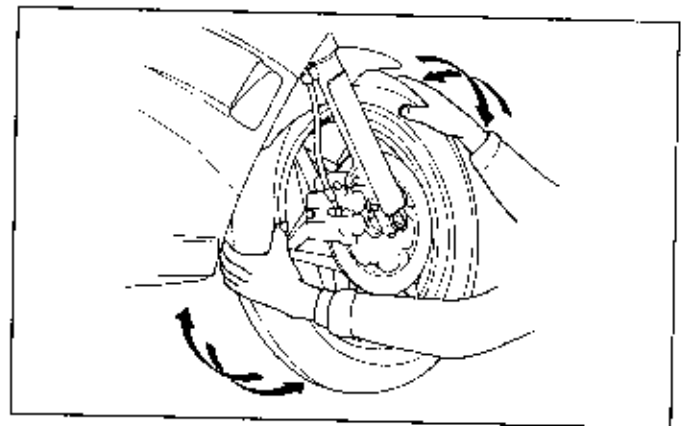

Raise the rear wheel, and check for play in either the wheel or the swingarm pivot. Turn the wheel and check that it rotates smoothly with no unusual noises.

If abnormal conditions are suspected, check the rear wheel bearings.

NOTE

- As the swingarm pivot is included in this check, be sure to confirm the location of the play; i.e. from the wheel bearings or the swingarm pivot.

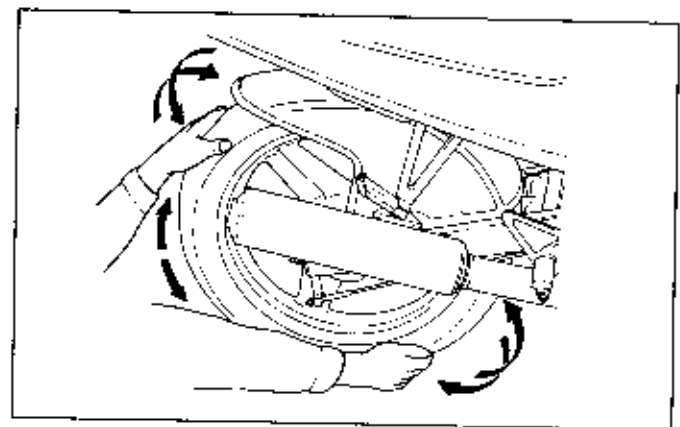

Check for looseness of bolts/nuts in connection with the following.

- Axles
- Axle nuts
- Rim/hub bolts

On models that have cotter pins, check that the pins are attached correctly.

Check for cracks, deformation, damage and corrosion etc. of the following parts.

- Rim
- Wheel
- Spokes

Raise the wheel, turn slowly and check for lateral and vertical oscillation.

Usable limit (front and rear wheels)

Lateral direction-Up to 2.0 mm (0.08 in)

Vertical direction-Up to 2.0 mm (0.08 in)

Oscillation of Comstar or cast wheels cannot be corrected. Therefore, check for bearing play or a bent axle shaft. If necessary, replace the wheel assembly.

If there is deformation of the rim on spoked wheels, replace the rim.

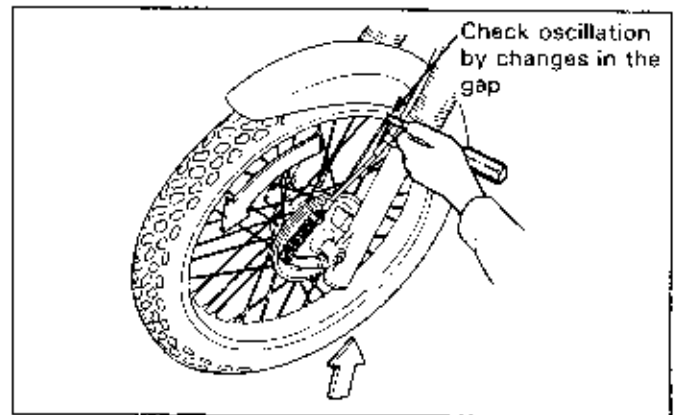
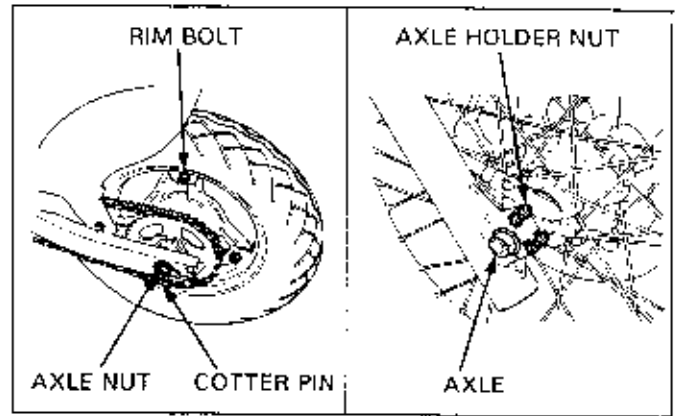

Inspect the spokes for looseness by tapping them with a screwdriver.

If a spoke does not sound clearly, or if it sounds different from the other spokes, tighten it.

Tap on the spokes and be sure that the clear metallic sound of the same tone can be heard on all spokes.

NOTE

- The spoke nipples are made of soft material. Be sure to tighten the spokes with the proper size spoke wrench. After tightening, check the rim for runout.

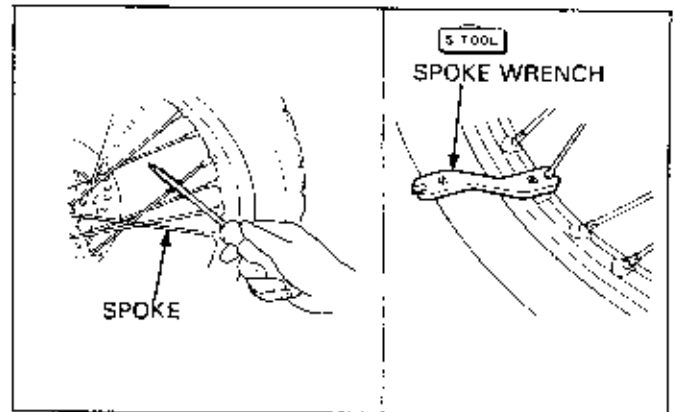

Check the pressure of each tire with a pressure gauge.

Check tire pressures when the tires are cold to assure accurate, comparative measurements. Checking tires after they are warm will give inaccurate readings.

WARNING

- Riding with incorrect tire pressure can affect and impair steering response and may result in a sudden tire deflation.

CAUTION

- Operation without optimum tire pressure will cause uneven tire wear.

Tire pressure specifications differ with each model. Refer to the Model Specific manual for the correct pressures.

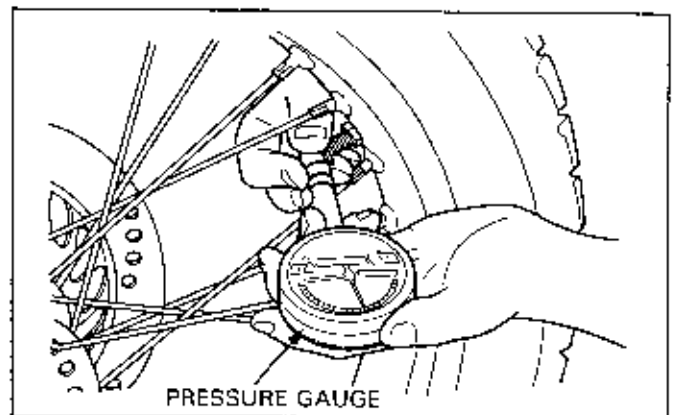

MAINTENANCE

Check for cracks and damage to the tire tread and walls and replace the tire if necessary.

Check for nails, pieces of metal and stones etc. which may have become lodged within the tread or embedded in the tires.

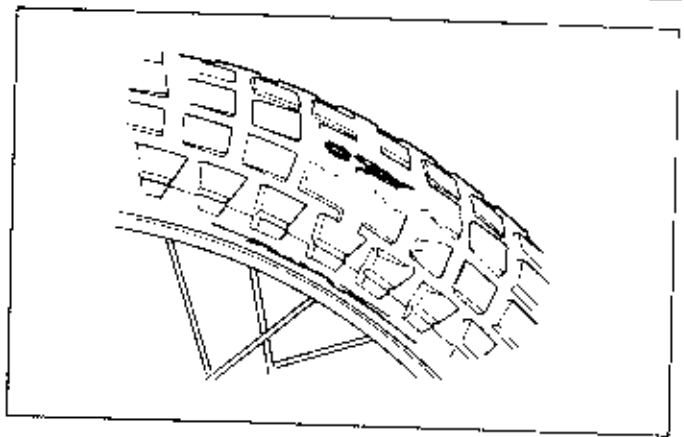

Tread depth can be observed directly or by use of the depth gauge.

- If the tread depth is below minimum tread depth the tire should be replaced.
- Replace the tire if the wear limit indicator can be observed. Check also for uneven wear of the tires.

NOTE

- Wear indicators "Δ" are distributed at several locations around the tire's side wall for ease of inspection.

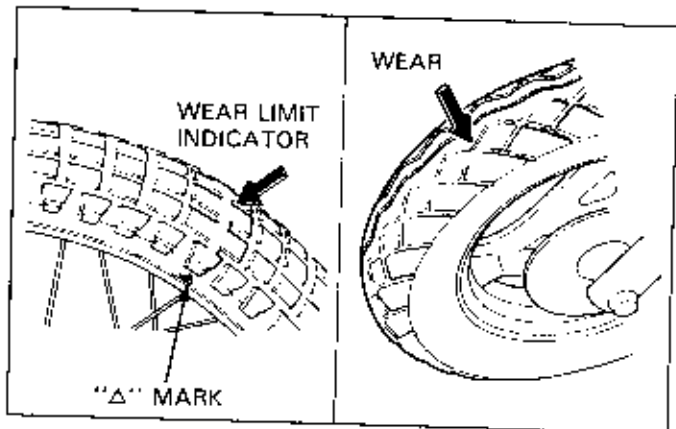

STEERING HEAD BEARINGS

Securely support the vehicle from beneath the frame with the front wheel off the ground. Turn the handlebar from left to right and check that the movement is smooth. If the operation is not smooth or the handlebar snags or has a heavy feel in certain locations, check that there is no interference from cables or wire harnesses. If these are not the cause, check for wear or damage to the steering head bearings.

Check for misalignment of the front wheel with respect to the handlebar. If the wheel is out of alignment, loosen the wheel and fork assembly bolts/nuts, align and re-tighten. If the wheel cannot be aligned, check for bent suspension components or a bent frame.

If the handlebar shows unusual shake during normal running conditions, check the handlebar mounting fasteners and wheel etc.

Turn the handlebar fully from left to right, and vice-versa, to check that there is no difference between the two directions of movement. Check also that there is no interference between the handlebar and frame.

Also inspect for snagging of wires and harnesses on the fork stops on the lower fork bridge.

If the handlebar moves unevenly, binds or has vertical movement, adjust the steering head bearings by turning the steering bearing adjustment nut. Refer to the Model Specific manual for proper procedure.

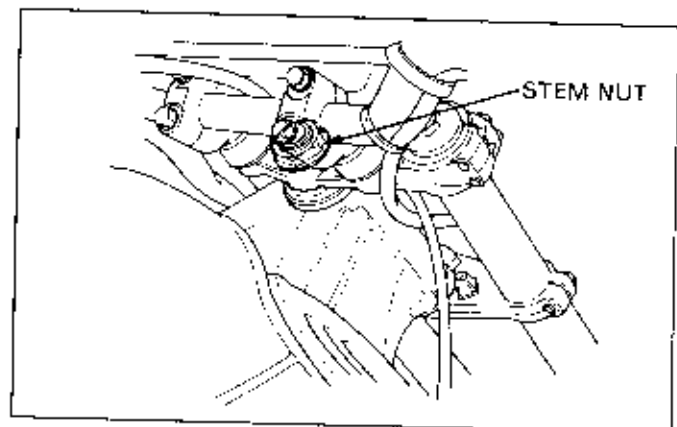
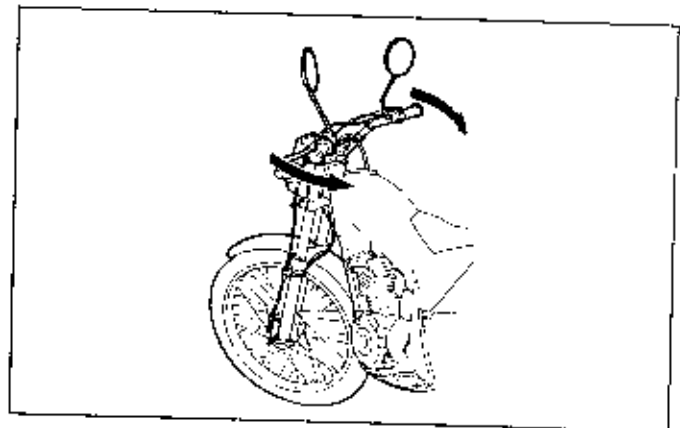

WHEEL ALIGNMENT (FOUR TRAX)

On FOUR TRAX models, inspect and adjust the front wheel alignment (toe-in, camber and caster) as necessary.

TOE-IN

Place the vehicle on level ground with the front wheels facing straight ahead.

Mark the centers of the tires with chalk to indicate the axle center height.

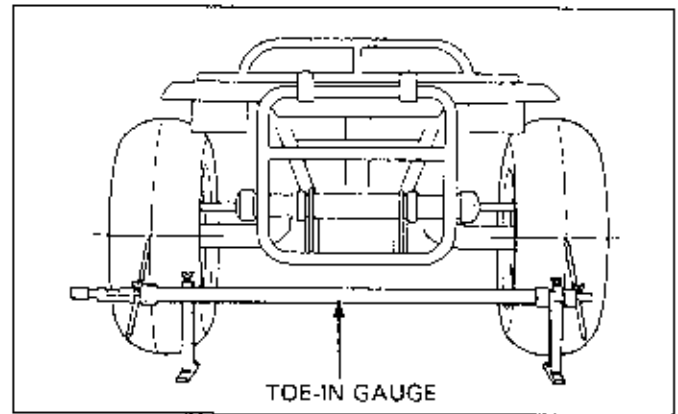

Align the toe-in gauge with the marks on the tires as shown. Check the readings on the gauges scales.

Slowly move the vehicle back until the wheels have turned 180° so the marks on the tires are aligned with the gauge height on the rear side.

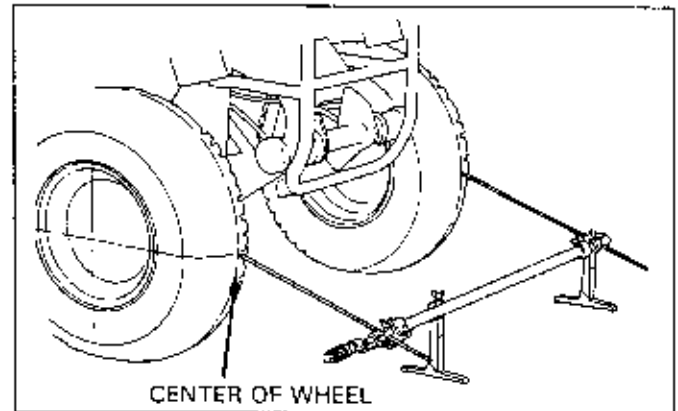

Measure the toe-in on the rear part of the tires at the same points.

When the toe-in is out of specification, adjust it by changing the length of the tie-rods equally while measuring the toe-in.

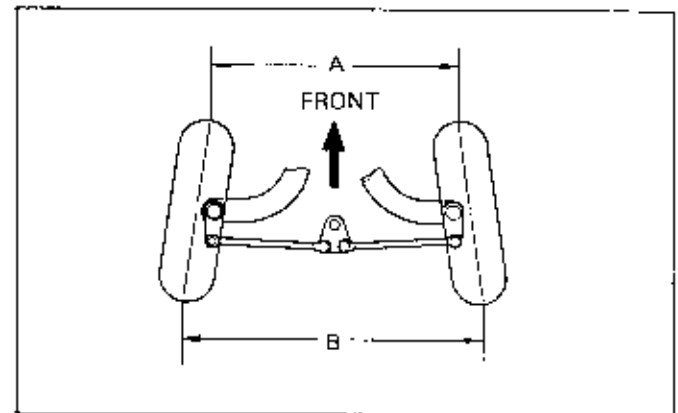

CAMBER/CASTER

Remove the wheel cap, cotter pin and front axle nut.

Install an attachment onto the front axle.
Put the camber and caster gauge onto the attachment.
Measure the camber.

Set the turn gauge under the front wheels.
Measure the caster.

Camber and caster are not adjustable. If they are out of specification, check the suspension and frame for damage and replace any parts necessary, then recheck alignment.

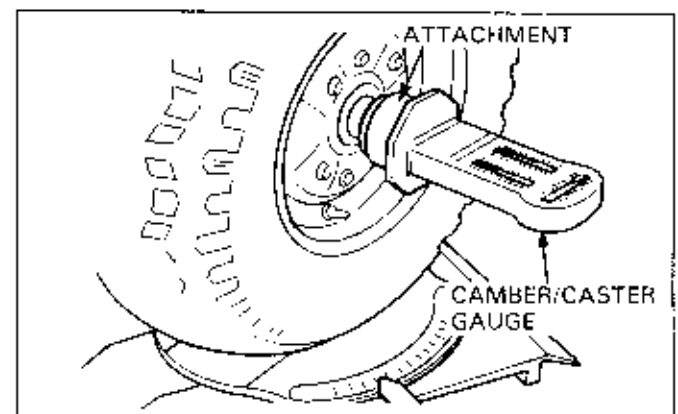

3. ENGINE TESTING

SERVICE INFORMATION	3-1	COMPRESSION TESTING	3-2
TROUBLESHOOTING	3-1	LEAK-DOWN TESTING	3-3

SERVICE INFORMATION

Compression and leak-down tests offer important knowledge of the mechanical condition of the engine in question. Both tests must be done to accurately evaluate engine condition. A compression test can quickly show if all contributing factors allow engine operation within basic service limits or if either the piston rings/cylinder(s), or the valves/valve seats in the case of 4-strokes, are suspect. In order for a compression test to be accurate, the instructions must be followed closely, the engine must contain only standard components and the battery on electric start models must be in perfect condition. A leak-down test can effectively pin-point whether the piston rings/cylinder(s), valves/valve seats, head gasket, or crankcase seals and gaskets in the case of 2-strokes, individually or all together are in need of service.

TROUBLESHOOTING

Cylinder compression is low or uneven

- Faulty valve mechanism
 - Incorrect valve clearance
 - Bent, burned or sticking valves
 - Worn or damaged valve seat
 - Incorrect valve timing
 - Broken valve spring
 - Faulty hydraulic valve adjuster
- Faulty cylinder head
 - Leaking or damaged head gasket
 - Warped or cracked cylinder head surface
- Faulty cylinder or piston
 - Worn or damaged piston ring(s)
 - Worn piston or cylinder
 - Sticked piston ring in the ring groove

NOTE

- On the 2-stroke engine, inspect the following items when compression is low or uneven with signs of lean air/fuel mixture.
 - Damaged reed valve
 - Damaged crankshaft seal
 - Damaged crankcase or cylinder base gasket

High cylinder compression

- Excessive carbon build-up on piston or combustion chamber

COMPRESSION TESTING

GENERAL

A compression test is a quick and easy way to check the general condition of an engine. This test should be performed prior to any tune-up work, especially if the machine did not come in under its own power. If the engine has a burnt valve for instance, the customer should be notified that the tune-up will have no benefit without the other necessary engine work. A compression test should also be done if you feel that the motorcycle, scooter or ATV lacks power, especially during acceleration.

A compression test can be inconclusive though, if the engine is not completely stock, if the battery is not in perfect condition (in electric-start models, engine cranking speed may be low) or if the test instructions are not followed completely. In each of these situations, the compression registered will be lower than the service limit in the Model Specific service manual.

When you do get a valid compression test, there is something else to consider.

What if the compression is below the service limit, or if the compression is relatively even between each cylinder, and the engine is not smoking? There may be no reason for an expensive rebuild on a good running engine. If, on the other hand, the compression on any one cylinder in a twin or multi-cylinder engine is significantly lower, the engine must be rebuilt.

TESTING

NOTE

- If the motorcycle has a decompressor, be sure it is adjusted properly before checking compression. On motorcycles equipped with an automatic decompression starting system as first introduced on the XR600R and NX650, the decompressors must be deactivated prior to checking.

Warm up the engine to normal operating temperature. Ten minutes of stop and go riding is sufficient.

Stop the engine and remove a spark plug from each cylinder. Install the compression gauge attachment to the cylinder to be tested.

Connect the compression gauge

NOTE

- Make sure that there are no leaks around the attachment.

TOOL:

COMPRESSION GAUGE 07305-0010000

Kick start models:

Fully open the throttle and choke valves, strongly kick the starter pedal through several times, and check the compression.

Electric start models:

Turn the engine stop switch "OFF"

Fully open the throttle and choke valves, crank the engine with the starter motor, and check the compression.

NOTE

- To avoid discharging the battery, do not operate the electric starter for more than seven seconds.

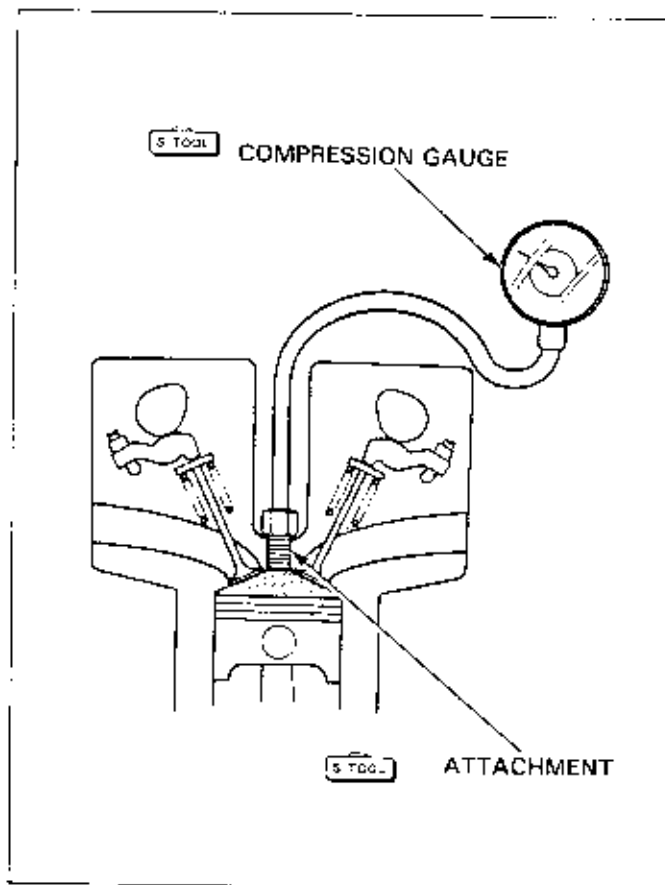

If compression is low, drop small amount of clean engine oil into the cylinder, then recheck the compression.

- If compression increases to more than the previous reading, inspect the cylinder and piston rings.
- If compression remains low, check the valves, valve seats and cylinder head.
- If compression is high, check for the accumulation of carbon deposits in the combustion chamber and/or the piston head.

LEAK-DOWN TESTING

4-STROKE LEAK-DOWN TEST INFORMATION

A leak-down test is an more comprehensive engine diagnostic test than a compression test. The leak-down tester consists of a calibrated pressure gauge connected to a pressure regulator and a flow restrictor.

The tester allows you to measure the rate at which air leaks past a cylinder's rings and valves.

There are several tools, specifically designed for leak-down testing 4-stroke engines, that are commercially available from several general tool sources.

A leak-down test provides a clear indication of whether or not the combustion chamber is sealing properly. The test involves pressurizing the combustion chamber and measuring the rate at which the air is lost past the rings and valves (or head gasket). A range of the allowable percentage of leak-down past the rings and valves is suggested by each tester manufacturer. But perhaps more important than a determination of whether the engine needs repair, is to find out more precisely where the problem lies.

The first step in the test is to install the hose from the tool into the spark plug hole, as you would in a compression test. Next position the crankshaft with the piston at top dead center. Be sure to remove the wrench from the crankshaft after positioning in case the air pressure against the piston puts the crankshaft in motion.

Then pressurize the combustion chamber with a steady, regulated pressure, again, as instructed by the tester manufacturer. Now you simply listen to the airbox, exhaust and crankcase filler cap to determine whether the intake valve(s), exhaust valve(s) or rings, respectively, are leaking.

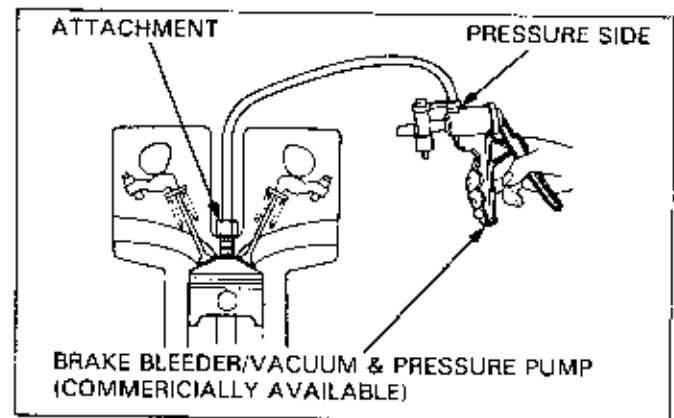

ENGINE TESTING

Squirting a little soapy water around the cylinder and head mating area will tell you if the head gasket is leaking to the outside atmosphere. Checking for bubbles in the cooling system of a liquid-cooled machine will tell you whether or not the head gasket is leaking into the cooling passages. The only thing this test won't tell you is the difference between a head gasket leak into the adjacent cam chain (or gear) well, and a leak past the piston rings.

Be sure to follow the leak-down test tool manufacturer's instructions precisely when making this inspection.

2-STROKE PRESSURE/VACUUM LEAK-DOWN TEST INFORMATION

Regular crankcase leak-down testing is much more important to the lifespan of a 2-stroke engine than a 4 stroke. Because the engine relies on a very precise air/fuel mixture to ensure proper engine lubrication, the slightest air leak can lead to an engine seizure. Consider these regularly scheduled tests as cheap insurance.

Pressure/vacuum tests on 2-stroke engines should always include both a pressure and a vacuum tests, both or which are performed with essentially the same equipment.

Pressure/vacuum leak-down test equipment, specifically designed for 2-stroke engines, is commercially available through various motorcycle and general tool sources.

A pressure/vacuum leak-down test tool consists of hand pressure/vacuum pump and various adaptors to seal your engine. The test provides a clear indication of where a leak, or leaks, exist. Possible areas for leaks include anywhere upstream of the carburetor until the mixture is ignited and forced out the exhaust. Leaks can occur between the mating surfaces of the crankcases if the gasket fails. If this gasket fails between the crankcase and the transmission, the mixture will become much richer as transmission oil is slowly drawn into the engine. Similarly, a leaking crankshaft seal on the transmission primary gear side will also consume transmission oil. Other air leaks include the cylinder base gasket, the magneto side crankshaft seal, leaks between the reed valve assembly and its gaskets, and leaks in the carburetor mounting boot between the carb and the reed valve.

The first step in the testing procedure is to remove the exhaust and to effectively seal the exhaust port. This is done with a plate fastened to bolt over the exhaust port, backed by a rubber sheet or with some form of expandable rubber plug. Next the carburetor is removed and a plug is clamped snugly in place where the carburetor was. This leaves only the seals and gaskets to show any defects they may have. Then an attachment is inserted into the spark plug hole and pressure applied with a hand pump. Often a brake bleeder pressure/vacuum tool is used for this purpose.

Spraying soapy water around the inlet tract, reed valve and crankcase mating areas will produce bubbles where there are leaks.

The vacuum portion of the test ensures that the negative sealing characteristics of the crankshaft seals are adequate.

Be sure to follow the leak-down test tool manufacturer's instructions precisely when making this inspection.

4. LUBRICATION

SERVICE INFORMATION	4-1	OIL PUMP INSPECTION	4-9
SERVICE DATA	4-1	PRESSURE RELIEF VALVE	4-10
TROUBLESHOOTING	4-2	OIL PUMP/OIL LINE BLEEDING (2-Stroke Engine)	4-11
SYSTEM DESCRIPTIONS	4-3	OIL COOLER INSPECTION	4-12
OIL PUMP DESCRIPTIONS	4-7		
OIL PRESSURE CHECK	4-9		

SERVICE INFORMATION

4-Stroke Engines:

- Refer to the Model Specific manual for:
 - Oil pump removal/installation
 - Oil strainer screen cleaning
 - Oil filter replacement
 - Oil level inspection/oil change
- The service procedures in this section can be performed with the engine oil drained.
- When removing and installing the oil pump use care not to allow dust or dirt to enter the engine.
- If any portion of the oil pump is worn beyond the specified service limits, replace the oil pump as an assembly.
- After the oil pump has been installed check that there are no oil leaks and that oil pressure is correct.

2-Stroke Engines:

- When removing and installing the oil pump, clean the engine around the pump and oil pump itself.
- Do not attempt to disassemble the oil pump.
- Bleed air from the oil pump if there is air in the oil inlet line and each time the oil line is disconnected.
- Fill the oil outlet line with oil whenever the oil outlet line is disconnected.
- Refer to section 2 for oil strainer screen cleaning and oil pump control cable adjustment.

SERVICE DATA

Use only recommended oil for your vehicle. Viscosity requirements vary according to the air temperature range encountered during operation. Refer to the Model Specific manual for specific oil recommendations for the model you are servicing.

GENERAL

Oil recommendations:

4-Stroke engine/ transmission and 2-Stroke transmission oil	API Service Classification: SE or SF Viscosity: SAE 10W-40	
	Other viscosities shown in the chart may be used when the average temperature in your riding area is within the indicated range.	
2-Stroke engine oil	Separate lubrication Mechanical lubrication systems	Pro-Honda Two-Stroke oil or equivalent
	Premix-Type systems	Pro-Honda Two-Stroke oil or equivalent (no concentrates) 20:1 is the only recommended fuel/oil ratio

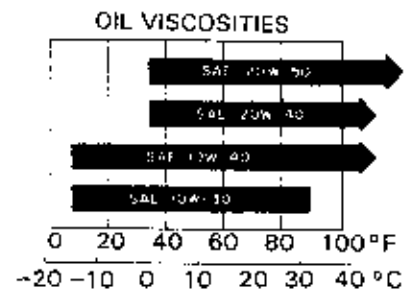

TROUBLESHOOTING

4-Stroke Engines:

Oil level low

- Oil consumption
- External oil leaks.
- Worn piston ring or incorrect piston ring installation
- Worn valve guide or seal.
- Oil pump worn or damaged (Dry sump engine)

Oil contamination (White appearance)

- From coolant mixing with oil (liquid-cooled engine)
 - Faulty water pump mechanical seal.
 - Faulty head gasket.
 - Water leak in crankcase.

Low or no oil pressure

- Clogged oil orifice and/or orifices.
- Incorrect oil being used.

Only On Models Equipped With Oil Pressure Switch:

High oil pressure

- Pressure relief valve stuck closed.
- Plugged oil filter, gallery, or metering orifice.
- Incorrect oil being used.

Low oil pressure

- Pressure relief valve stuck open.
- Clogged oil filter screen.
- Oil pump worn or damaged.
- Internal oil leaks.
- Incorrect oil being used.
- Low oil level

No oil pressure

- Oil level too low.
- Oil pump drive chain or drive sprocket broken.
- Oil pump damaged (pump shaft)
- Internal oil leaks.

2-Stroke Engines With Separate Oiling System:

Excessive smoke and/or carbon on spark plug

- Faulty oil pump (too much oil flow)
- Low quality engine oil

Overheating or seized piston

- No oil in tank or clogged oil line
- Air in oil lines
- Faulty oil pump (too little oil flow)
- Clogged oil strainer
- Oil not flowing out of tank
- Clogged oil tank cap breather hole
- Clogged oil strainer

2-Stroke Engines Using Premixed Fuel/Oil:

Excessive smoke and/or carbon on spark plug

- Improper jetting for altitude, air temperature and track conditions
- Improperly mixed fuel/oil—too much oil in fuel
- Fuel/oil mixture too old—gasoline has evaporated/gone bad

Overheating or seized piston

- Improper jetting for altitude, air temperature and track conditions
- Fuel/oil mixture too old—oxidized oil/degraded lubrication
- Premix oil too old—oxidized/degraded lubrication
- Poor quality premix oil
- Improperly mixed fuel/oil—too little oil in fuel
- Using fuel/oil premix ratio other than 20:1

SYSTEM DESCRIPTIONS

4-STROKE SYSTEMS

TYPICAL OIL FLOW PATTERN

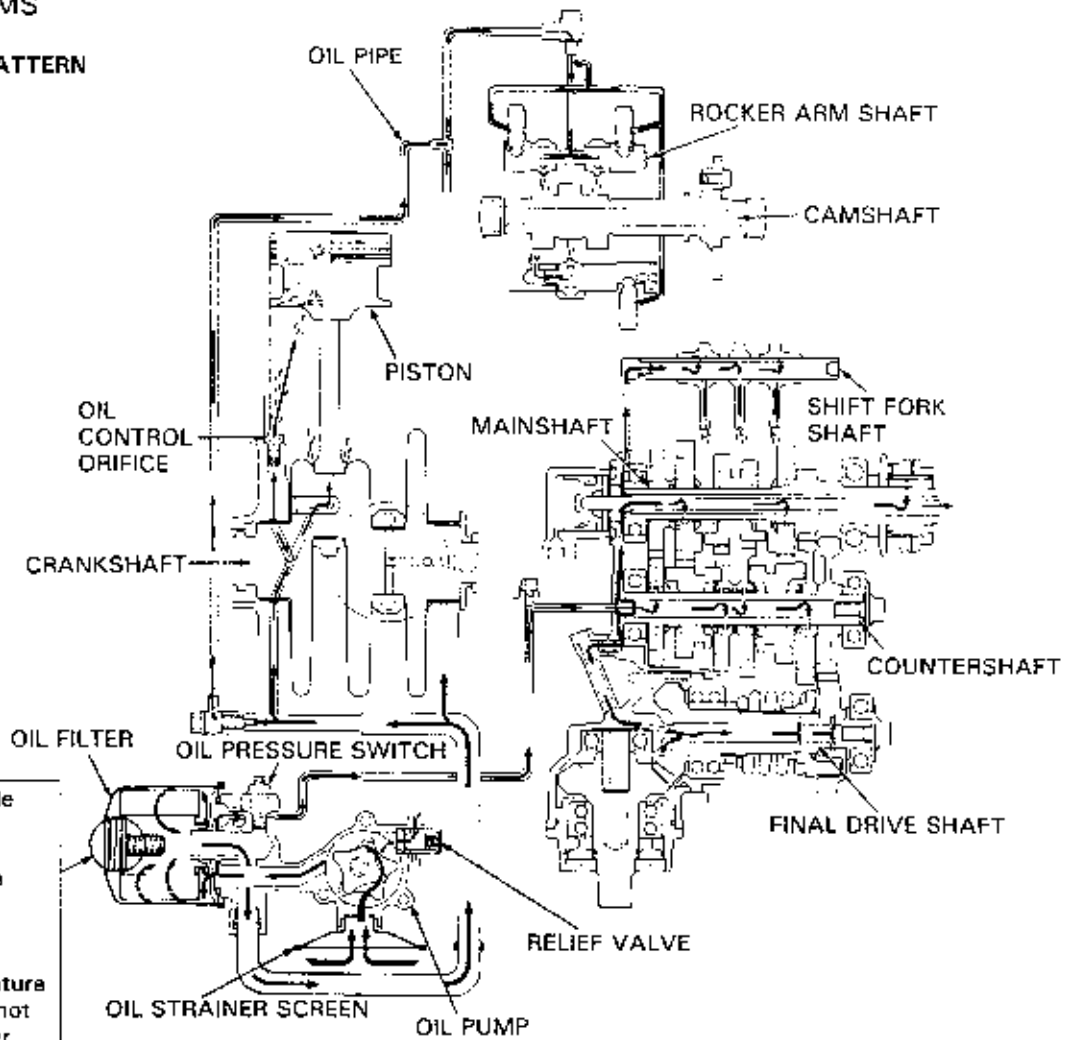

NOTE

Some systems include a relief valve that opens to maintain the oil flow when the filter is excessively restricted due to contaminants, or, when the oil temperature is so low that it will not flow through the filter.

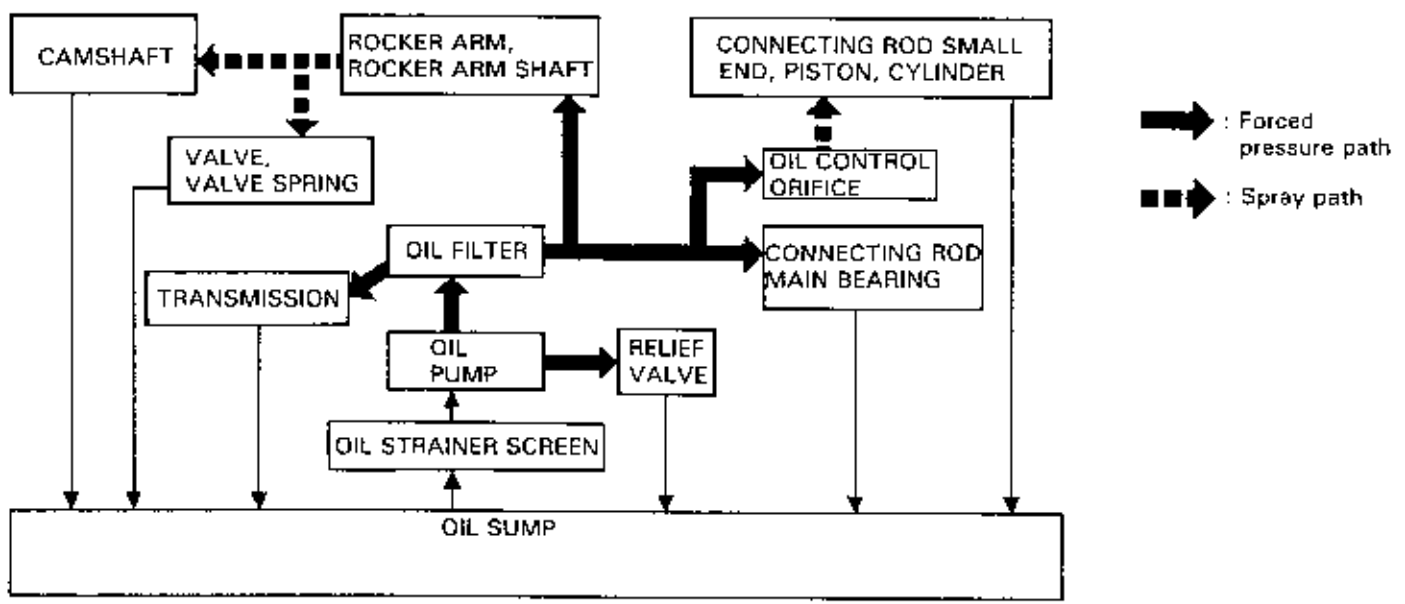

FOUR-STROKE ENGINES

Wet-Sump Type

Wet-sump engines contain their total oil volume within their crankcases. In these systems, oil is pumped from the sump in the crankcase, through a strainer screen and/or oil filter and then is pressure fed to various engine components. Oil returning from these now lubricated areas flows back into the sump by gravity.

Some wet-sump engines use only a strainer screen to filter the oil. Others use a combination of a strainer screen and a centrifugal-type filter, or a more conventional pleated paper-type filter.

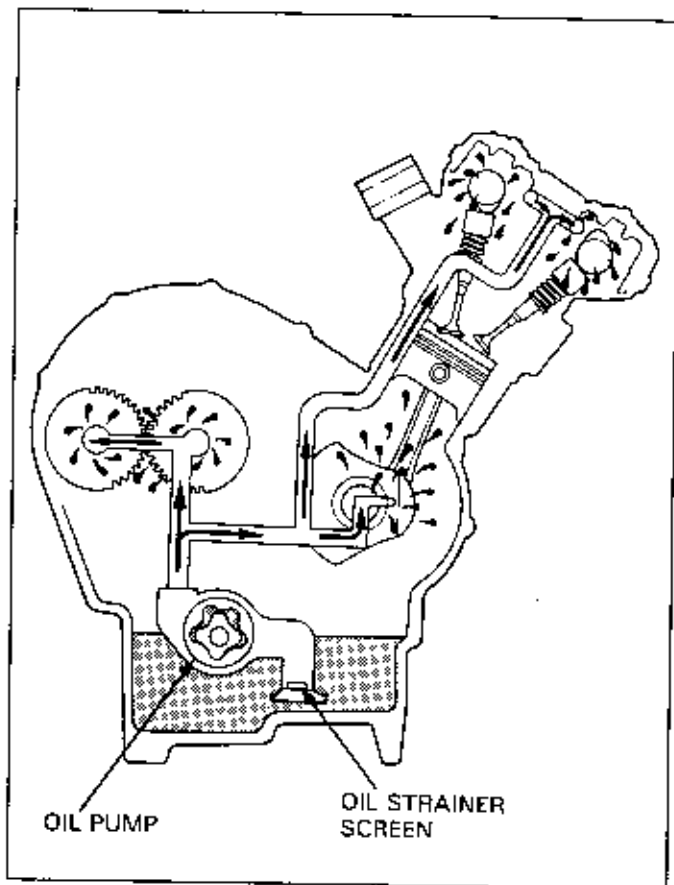

Dry-Sump Type

Dry-sump systems use an external oil tank and dual-function oil pumps. In this system, the pump draws in oil for delivery to the various components and pumps oil out of the sump and back to the oil tank.

Since this design eliminates the need for space to contain the oil within the lower portion of the crankcases, the engine can be positioned lower than would otherwise be possible. This design often incorporates routing and oil storage configurations that aid in lowering oil temperature.

General

A spray-type system is often utilized in either design illustrated here as well as in some two-strokes engine designs. Here oil is literally sprayed through oil jets directly into internal components such as the connecting rod, to help ensure lubrication and cooling of the rods and pistons.

Some systems include oil pressure-controlling relief valves to help ensure lubrication even if the filter is clogged or the oil temperature is so low that it will not flow through the filter.

Oil filters and/or strainer screens are positioned within the lubrication system to trap contaminants before the oil is routed back into the lubricant pathways.

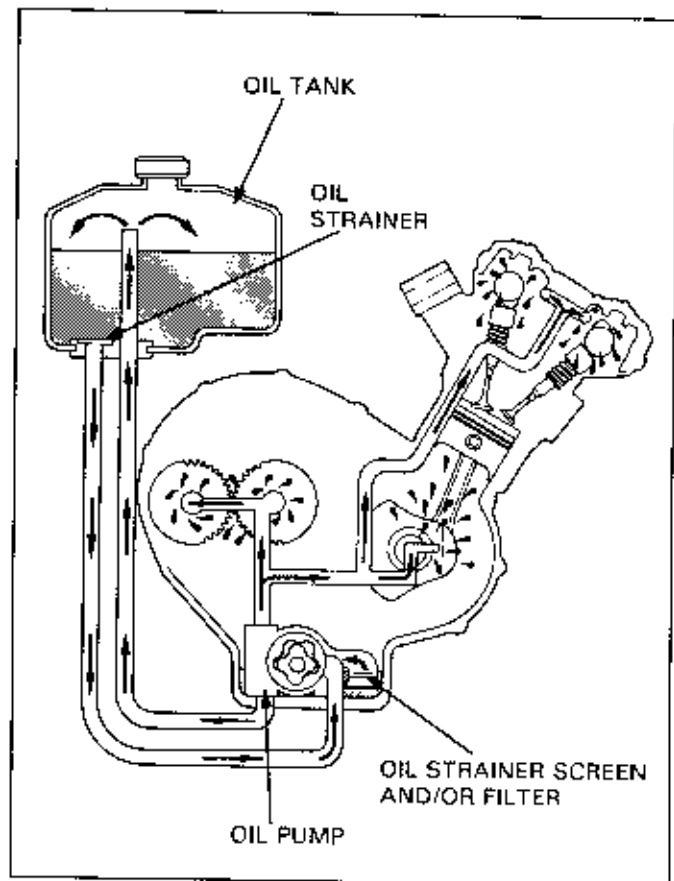

TWO-STROKE LUBRICATION SYSTEMS

Unlike four-stroke engines, two-stroke engines use the internal crankcase area as a suction chamber and, therefore, cannot use a sump-type oiling system. Consequently, the following two systems have been adopted in order to provide lubrication to the cylinder, piston rings, connecting rod and crankshaft bearings. Each system type relies on oil ingested together with the gasoline. In Separate Oil systems, engine lubrication oil is introduced downstream of the carburetor. Oil is combined with the gasoline before it reaches the carburetor in Premixed systems.

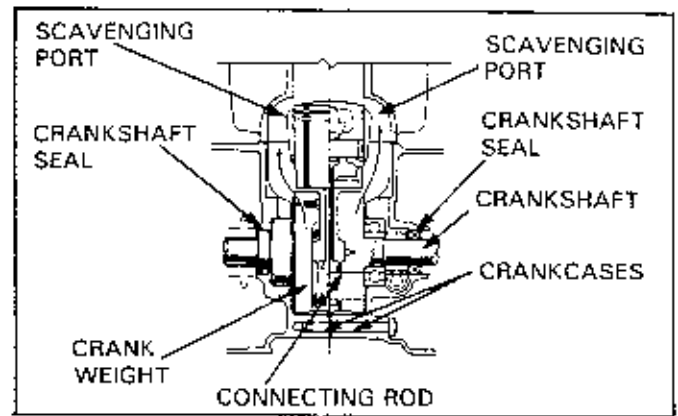

SEPARATE OIL SYSTEMS:

Virtually all street motorcycle and scooter two-stroke engines use a pump-operated system to lubricate engine components. Oil in this type of system is drawn from a separate oil tank by an oil pump that introduces the oil directly into the air/fuel inlet tract beyond the carburetor.

Periodic level checks and refilling of the oil tank is required since the oil in the tank is continually drawn upon when the engine is running.

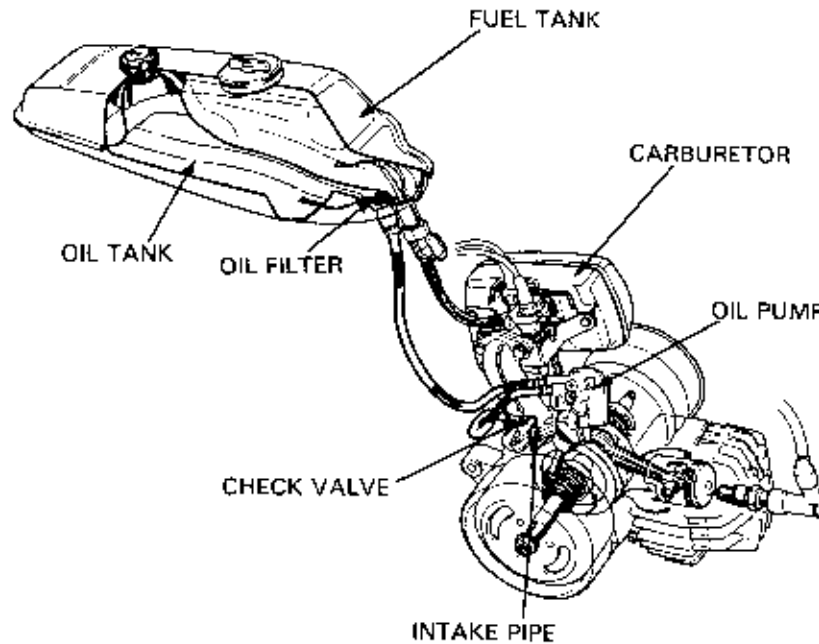

The amount of lubricant delivered to the engine is dependant on both engine rpm and throttle position.

Some of these systems include provisions for circulating the transmission oil within the gearbox portion of the crankcases with the same oil pump.

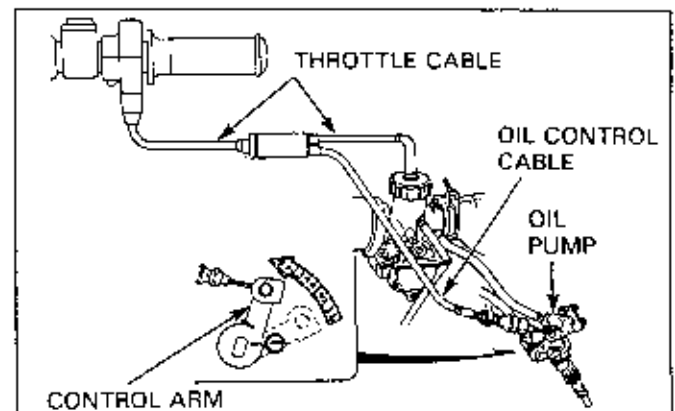

LUBRICATION

PREMIXED (OIL IN FUEL) SYSTEMS:

Premixing engine oil with gasoline is the most widely used system on competition models.

The combined air/fuel/oil mixture is introduced directly through the inlet tract with the assistance of the carburetor. Lubrication to the crankshaft and both connecting rod bearings as well as the piston rings and cylinder walls is achieved as this mixture is drawn into the crankcase by the suction of the piston movement.

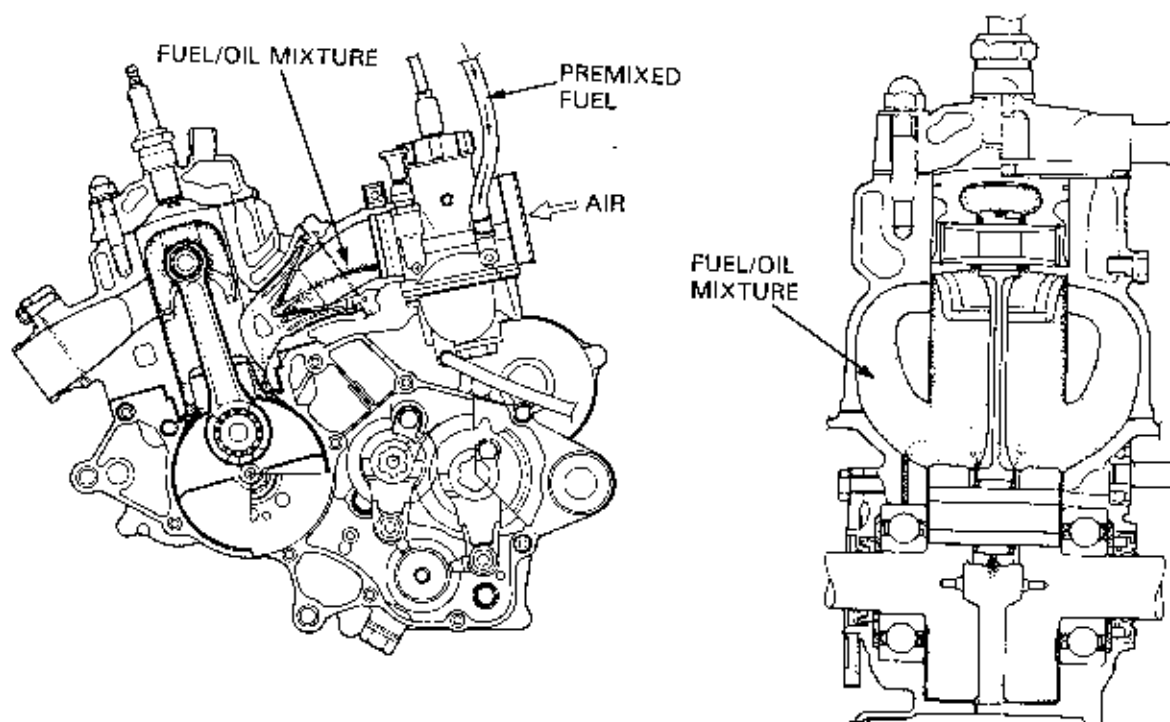

It is important to **USE ONLY A 20:1 FUEL/OIL RATIO**. All Honda engines are designed to operate most efficiently and with greatest durability using a 20:1 premix ratio. All standard carburetor jetting is based on this ratio.

Standard jetting is based on 20:1 at sea level and 20°C (68°F).

CAUTION

- Use of a fuel/oil premix ratio other than 20:1 may affect overall jetting, engine performance and may lead to premature engine wear or damage.

Freshness of the fuel/oil mixture is very important to both the overall performance of the machine as well as the lubricating efficiency of the oil.

Only use gasoline that has been pumped from a high-volume station within the previous two weeks if optimal competition performance is required. Even general use applications call for gasoline that is no more than eight weeks old.

For optimal lubrication efficiency in this system, use the premixed fuel/oil within 24 hours after it is mixed. Two-stroke premix oil that is not stored in resealable containers should be discarded in a proper manner if it is not used completely within one month after opening. Oil stored in non sealed container is subject to oxidation that degrades the oil's lubrication qualities.

Vegetable-type premix oils separate from gasoline more easily than mineral oils, especially in cold weather. It is advisable to use mineral oil when ambient temperatures below 0°C (32°F) are expected.

CAUTION

- Mixing vegetable and mineral-based oils will cause premature engine wear or damage.

OIL PUMP DESCRIPTIONS

TROCHOID TYPE

The trochoid-type oil pump is the most common oil pump design used in 4-stroke engines. It is designed to turn two rotors within a casing, with an inner rotor fixed on the pump shaft (drive shaft) and an outer rotor on its circumference. When the inner rotor is turned by means of the oil pump shaft, the outer rotor also turns, with the clearance between the two rotors varying. Lubricant is drawn through by suction when the clearance is enlarged. Oil is delivered to the opposite side through this clearance and is then routed into the discharge passage when the clearance lessens. The more teeth the inner and outer rotors have, the less the amount of pulsation. The oil flow volume increases in direct proportion with the increase in thickness of the rotor dimension.

Some models have a double rotor trochoid-type oil pump which collects oil directly from both the oil cooler and the sump.

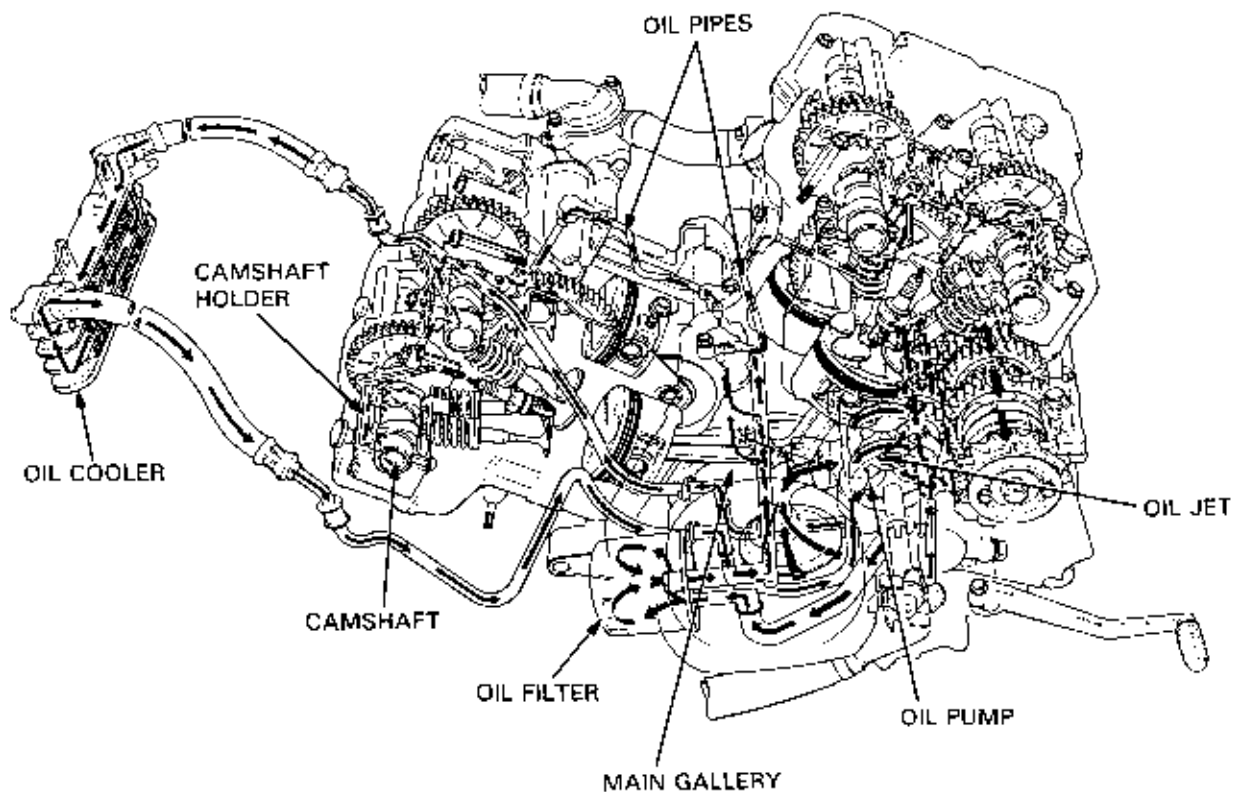
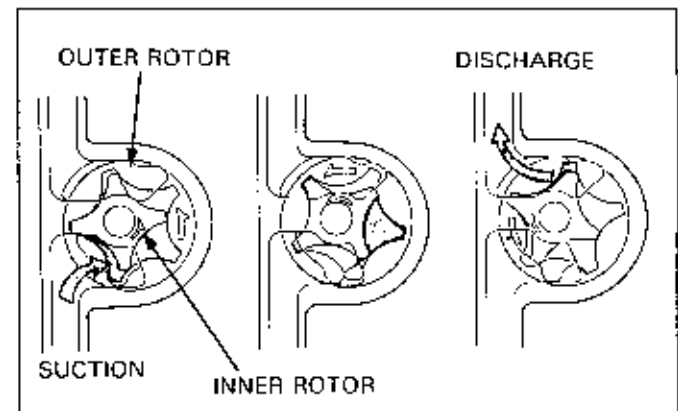
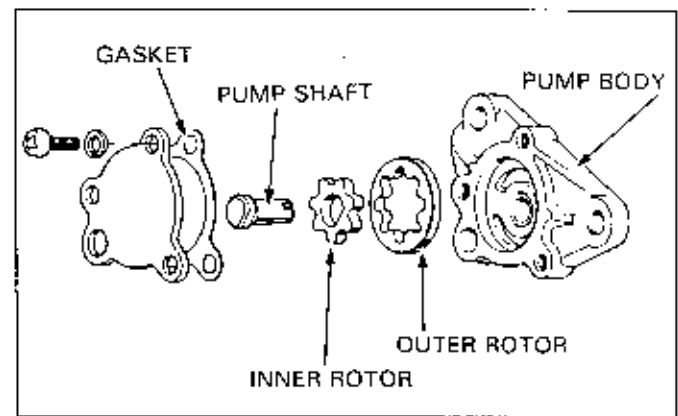

PLUNGER TYPE

Virtually all non premix lubricated 2-stroke engines are equipped with a plunger-type oil pump.

Some plunger pumps are driven by crankshaft via the oil pump gear shaft, and others are directly driven by crankshaft.

The oil pump cam is depressed under a spring. Turning the cam causes the plunger to reciprocate so that the pumping movement is repeated. The amount of lubricant is controlled proportionally with the cam rotation.

The pump is designed to control the amount of lubricant discharged per crankshaft rotation by varying the plunger stroke through the operation of the cam interlocked with the carburetor throttle.

The combined function of these two mechanisms allows the proper flow of lubricant depending on load conditions and engine rpm.

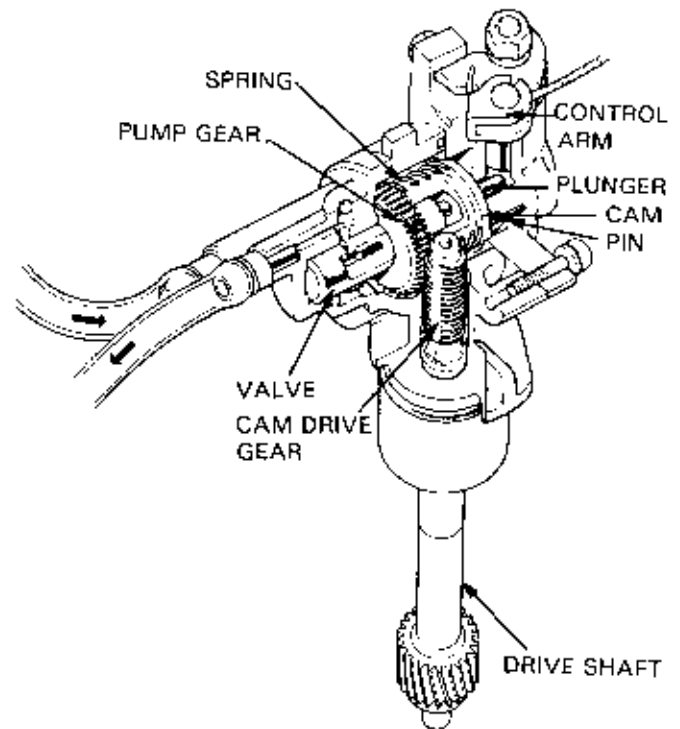

Oil Pump Operating Principle

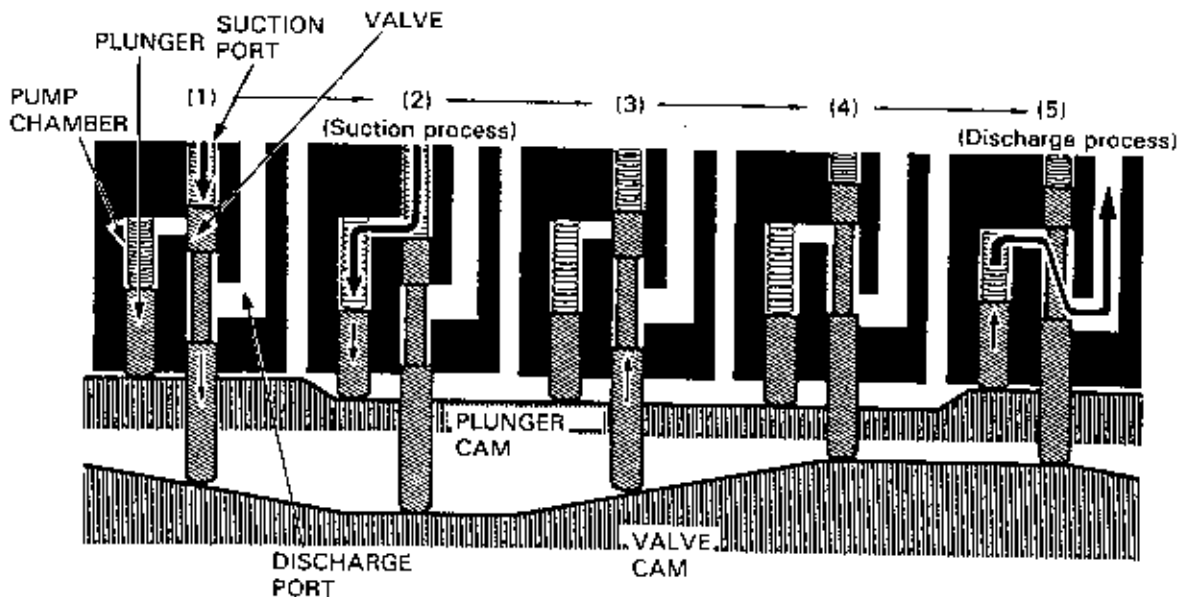

- (1) As the valve descends, it blocks the outlet passage while gradually opening the inlet passage.
- (2) Here at the "bottom dead center" position, the outlet passage is completely closed while the inlet passage is completely opened — allowing free flow of oil into the pump chamber.
- (3) With the oil chamber filled, the valve ascends — closing the inlet passage.
- (4) The valve ascends further, allowing free flow of oil through the outlet passage.
- (5) The plunger also ascends, compressing the oil inside the pump chamber and pumping oil out through the outlet passage, towards the intake pipe via the outlet line.

OIL PRESSURE CHECK

NOTE

- This procedure is for vehicles equipped with an oil pressure switch.
- If the engine is cold, the pressure reading will be abnormally high. Warm up the engine to normal operating temperature before starting this test.
- Refer to the Model Specific manual for specifications.

Stop the engine and pull off the switch cover. Disconnect the switch wire by removing the screw.

Turn the ignition switch ON and check that the oil warning light does not come on.

If the warning light comes on, there is a shorted circuit in the switch wire. Repair or replace as necessary.

Remove the oil pressure switch (see the Model Specific manual).

Install the attachment as necessary and connect the oil pressure gauge.

(S TOOL)

OIL PRESSURE GAUGE: 07506-3000000

ATTACHMENT: Refer to Model Specific manual.

Check the oil level and add the recommended oil if necessary.

Start the engine and check the oil pressure. If it is normal, replace the oil pressure switch.

Stop the engine.

Apply 3-BOND® sealant or equivalent to the pressure switch threads and install.

CAUTION

- Overtightening the switch can cause crankcase damage.

Connect the oil pressure switch wire and start the engine.

Check that the oil pressure warning indicator goes out in one or two seconds.

If the oil pressure warning indicator stays on, stop the engine immediately and determine the cause.

OIL PUMP INSPECTION

TROCHOID TYPE

NOTE

- Where there are two pair of inner and outer rotors, check each side of the pump as described below.
- Measure at several places and use the largest reading to compare the service limit.

Disassemble the oil pump and clean the parts with clean oil.

Set the inner and outer rotors into the pump body properly.

Measure body clearance (pump body-to-outer rotor) and tip clearance (inner rotor-to-outer rotor) using a feeler gauge.

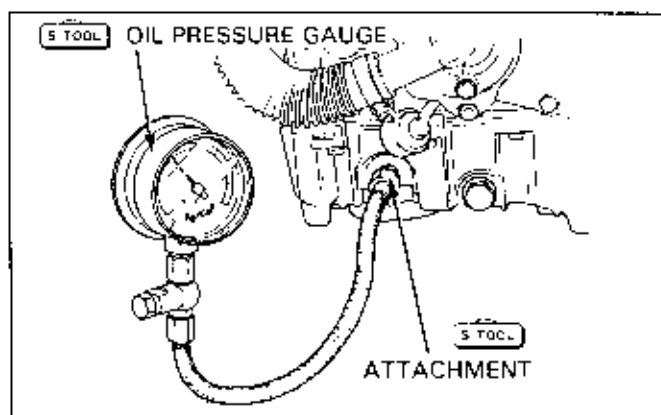

NOTE: Apply sealant only to the area shown.

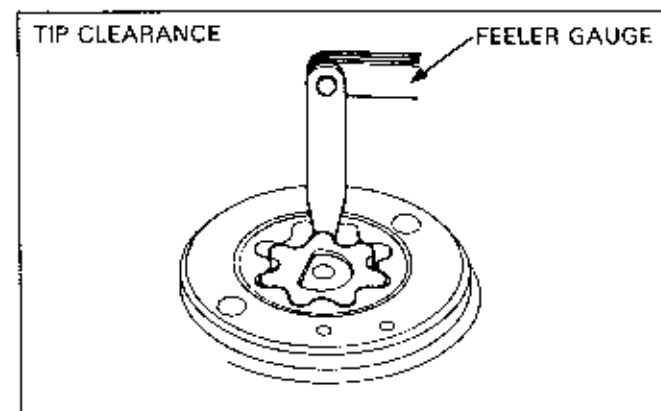
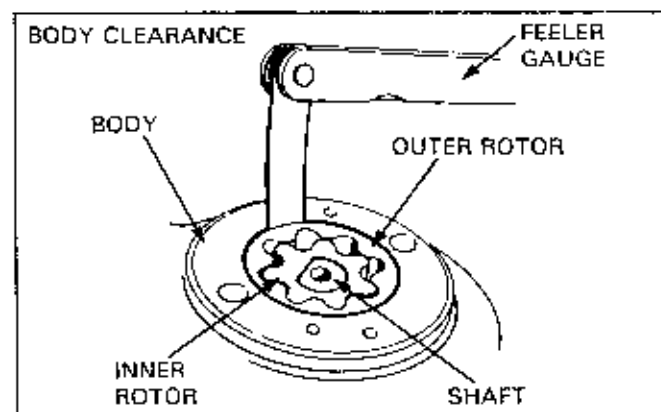
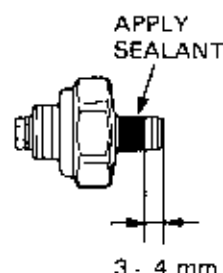

LUBRICATION

Measure the side clearance (rotor side-to-body) with a straight edge and feeler gauge.

NOTE

- If there is a cover gasket, measure the clearance with the gasket installed.

Refer to the Model Specific manual for all clearance specifications.

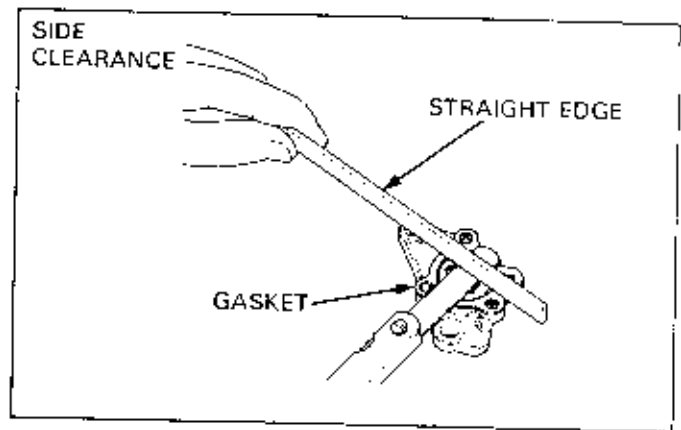

PLUNGER TYPE

NOTE

- Do not disassemble and try to repair a two-stroke oil pump; it will not operate properly once reassembled.
- Replace the pump if it is worn or damaged.

Remove the oil pump and inspect for the following:

- Worn or damaged pump gear
- Oil leaks from seals
- Binding pump shaft

Connect the oil tube from the oil tank to the suction side, then turn the shaft. Check that oil flows out of the outlet.

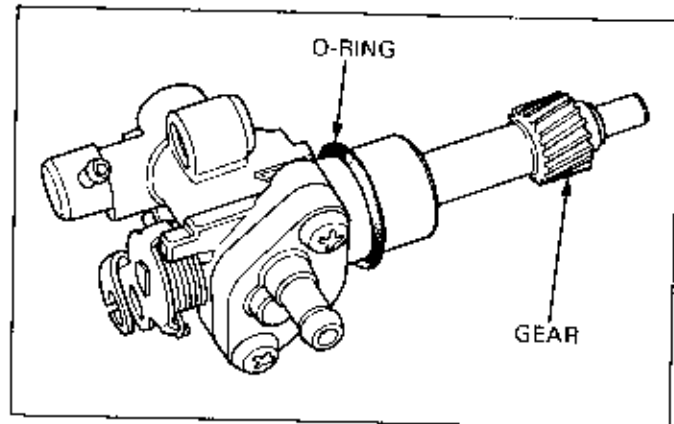

PRESSURE RELIEF VALVE

Remove the snap ring, washer, spring and valve from the valve body.

Check the valve and body for wear, scratches or damage. Check the snap ring groove for damage. If the snap ring groove is damaged, the oil supply will be reduced and the engine may seize.

NOTE

- Install the valve with the open side facing toward the spring.

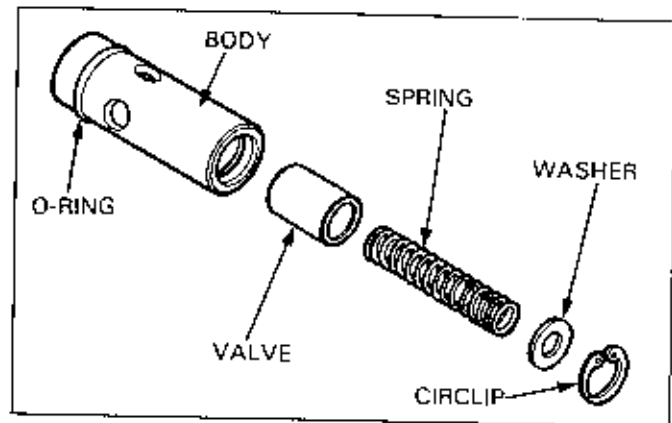

In-Set Type Oil pump

Remove the cutter pin, seat, spring and valve. Check the valve for wear or damage.

NOTE

- Install the valve with the closed side facing the spring.

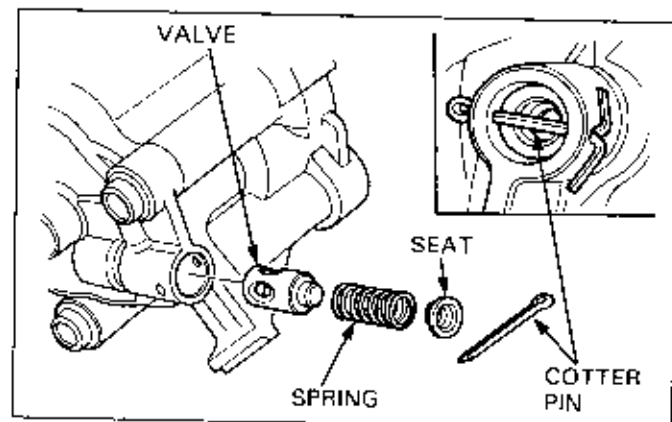

OIL PUMP/OIL LINE BLEEDING (2-STROKE ENGINES)

CAUTION

- Be sure to bleed all air from the oil system. Air in the oil system will block or restrict oil flow and can cause serious engine damage.

NOTE

- Bleed air from the oil suction line and oil pump whenever the oil lines and pump have been removed, there is no oil in the tank, or there is air in the oil lines.
- Bleed air from the oil suction line and pump first, then bleed the oil outlet line.

SUCTION LINE, OIL PUMP BLEEDING

Fill the oil tank with the recommended oil.
Place a shop towel around the oil pump.

Disconnect the oil lines from the oil pump, and fill the pump with oil through the pump outlet.

Let oil drip from the inlet line to expel any air that may be in the line, and then reconnect the suction line to the pump inlet. If there is a bleed bolt, loosen it until there are no air bubbles in the oil coming out of the bolt hole, then retighten the bleed bolt.

Check that there is no air in the oil line.

Next, bleed air from the oil outlet line.

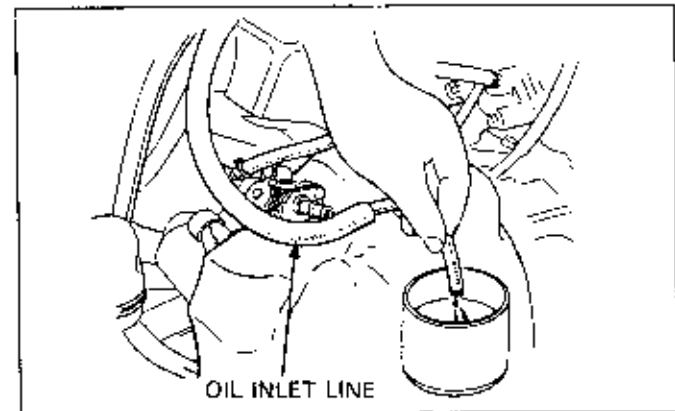
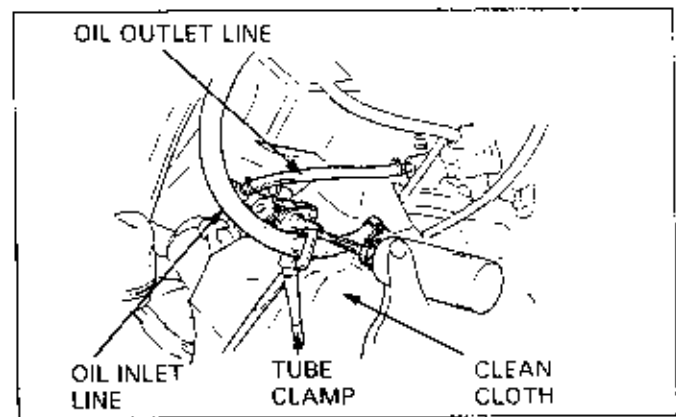

OUTLET LINE BLEEDING

Remove the oil outlet line and close the intake pipe joint. Bend the oil outlet line into a "U" form with both the ends parallel, and fill the oil outer line with clean oil.

Connect the oil outlet line to the oil pump joint.

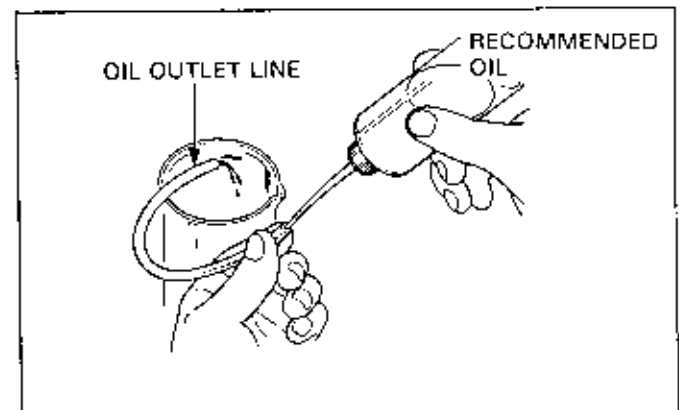

Start the engine and allow it to idle with the oil control lever in the fully open position, making sure that oil is flowing out of the oil outlet line.

⚠ WARNING

- Perform this operation in a well ventilated area. Exhaust contains poisonous carbon monoxide gas that can cause loss of consciousness and may lead to death.

CAUTION

- Run the engine at the lowest necessary rpm level to avoid possible engine damage if oil flow is restricted.

Stop the engine and again bleed air from the oil inlet line and oil pump if oil does not flow out within one minute. Then recheck oil flow.

Connect the oil outlet line to the intake pipe joint.

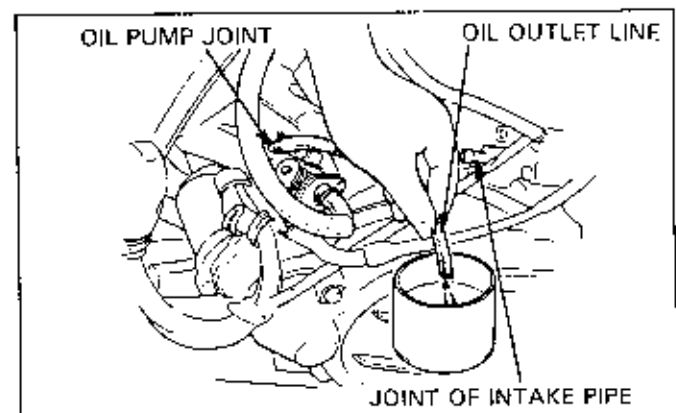

OIL COOLER INSPECTION

Check the oil line connections for leaks.

Check the oil cooler for bent or collapsed fins. Straighten the bent or collapsed fins with a suitable, small, blade-type screw driver if necessary.

Check the air passages for clogging or restriction.

Blow dirt out from between core fins with compressed air or wash off dirt with water.

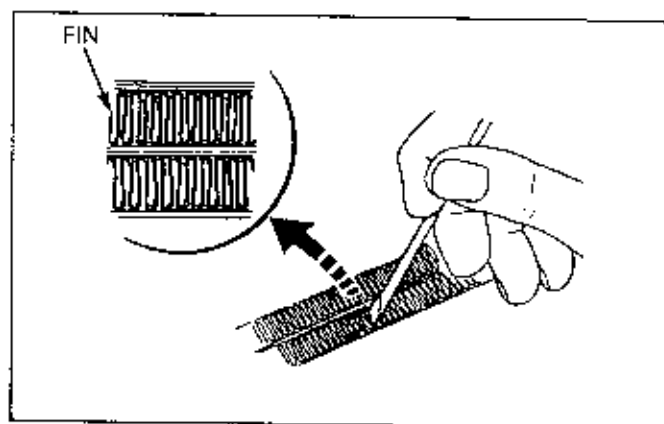

5. COOLING SYSTEM

SERVICE INFORMATION	5-1	SYSTEM TESTING	5-7
TROUBLESHOOTING	5-1	THERMOSTAT	5-8
SYSTEM DESCRIPTIONS	5-2	WATER PUMP	5-8
COOLANT	5-6		

SERVICE INFORMATION

⚠ WARNING

- Wait until the engine is cool before slowly removing the radiator cap. Removing the cap while the engine is hot and the coolant is under pressure may cause serious scalding.
- Radiator coolant is toxic. Keep it away from eyes, mouth, skin and clothes.
 - If any coolant gets in your eyes, rinse them with water and consult a doctor immediately.
 - If any coolant is swallowed, induce vomiting, gargle and consult a physician immediately.
 - If any coolant gets on your skin or clothes, rinse thoroughly with plenty of water.
- KEEP OUT OF REACH OF CHILDREN

- Add coolant at the reserve tank. Do not remove the radiator cap except to refill or drain the system.
- All cooling system service can be made with the engine in the frame.
- Avoid spilling coolant on painted surfaces.
- After servicing the system, check for leaks with a cooling system tester.
- Refer to section 25 for fan motor thermostatic switch and temperature sensor inspections.

TROUBLESHOOTING

Engine temperature too high

- Faulty temperature gauge or gauge sensor (see section 25)
- Thermostat stuck closed
- Faulty radiator cap
- Insufficient coolant
- Passages blocked in radiator, hoses, or water jacket
- Air in system
- Faulty cooling fan motor
- Faulty fan motor switch (see section 25)
- Faulty water pump

Engine temperature too low

- Faulty temperature gauge or gauge sensor
- Thermostat stuck open
- Faulty cooling fan motor switch (see section 25)

Coolant leaks

- Faulty pump mechanical seal
- Deteriorated O-rings
- Faulty radiator cap
- Damaged or deteriorated gaskets
- Loose hose connection or clamp
- Damaged or deteriorated hoses

SYSTEM DESCRIPTIONS

A liquid cooling system allows optimal engine operating temperature while preventing overheating and overcooling. The coolant is pumped through the system by means of a water pump. Combustion heat is absorbed by the coolant in the course of its passage through the water hoses, water jacket around the cylinder, and through the cylinder head. The coolant then passes into the radiator through the thermostat and upper radiator hose. The hot coolant is cooled by air in the course of its passage through the radiator and is then returned into the water pump through the lower radiator hose.

SYSTEM FLOW PATTERNS

TYPICAL 4-STROKE ENGINE:

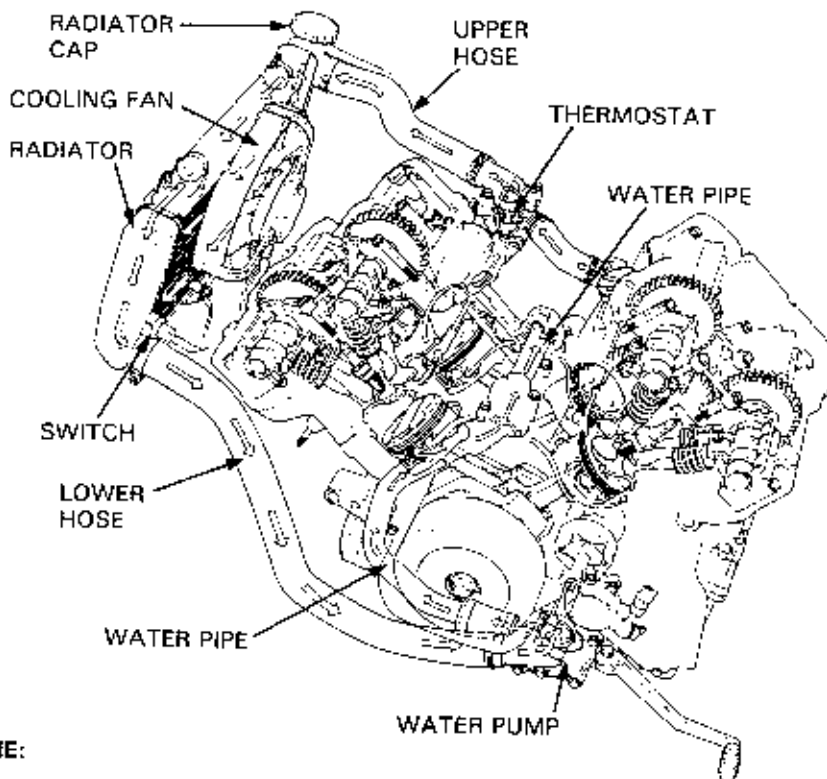

TYPICAL 2-STROKE ENGINE:

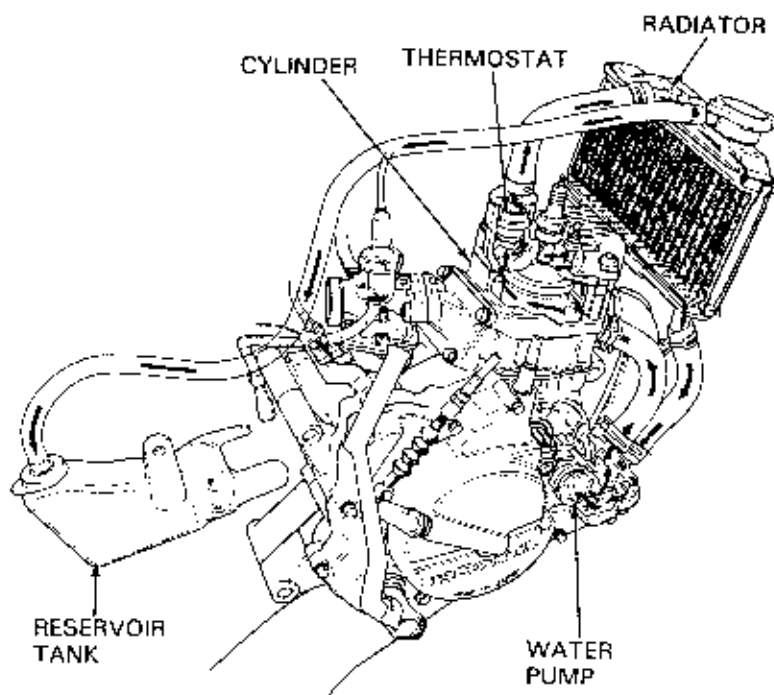

RADIATOR

Coolant temperature is decreased by dissipating heat into the air by means of the radiator fins as the coolant passes through the radiator tube. The larger the fin's surface area, the more the radiator exerts its cooling capacity.

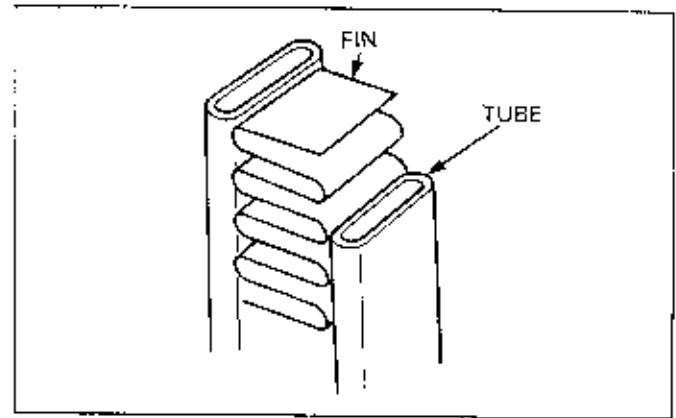

It is important that air is permitted to pass through the radiator fins so that the heat is dissipated from the coolant to the fins and into the atmosphere. Crushed or twisted fins will not permit heat to be dissipated because of inability of the air to pass through them, resulting in lowered cooling capacity. If 1/3 or more of the fins are crushed or twisted, the fins should be repaired using a small flat blade screwdriver.

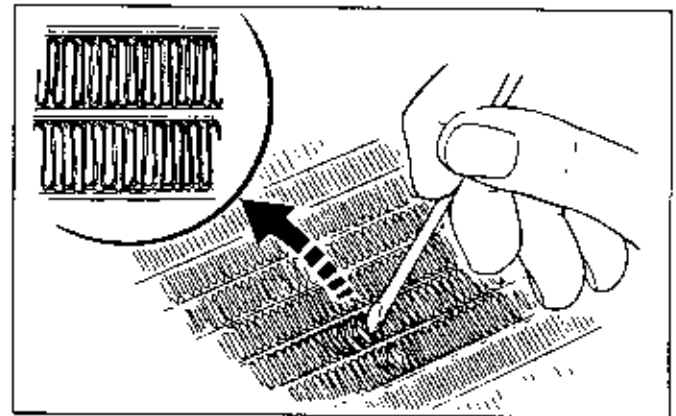

COOLING FAN

Heat is dissipated into the atmosphere because of the difference in temperature between the air and the coolant which has absorbed the heat.

If, however, the engine is not in operation (air around the radiator is stagnant) or when the atmospheric temperature is high, since the temperature difference between the atmosphere and the coolant becomes smaller, heat dissipation is decreased, adversely affecting engine capacity.

A cooling fan maintains the cooling performance under severe conditions. It forces air to flow through the radiator and around the engine to dissipate heat, whether the machine is moving or not.

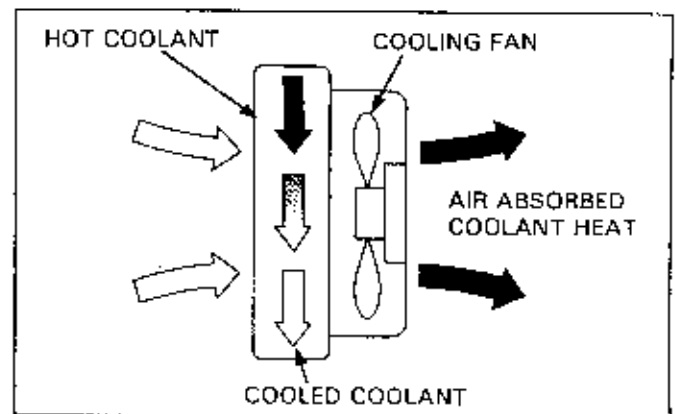

COOLING FAN SWITCH

The fan switch automatically starts or shuts down the cooling fan depending on the temperature of the coolant. While the fan motor switch resistance is normally too high to conduct a current (when the coolant temperature is low), when the coolant temperature rises, the switch resistance is reduced enough to conduct current and causes the cooling fan to turn.

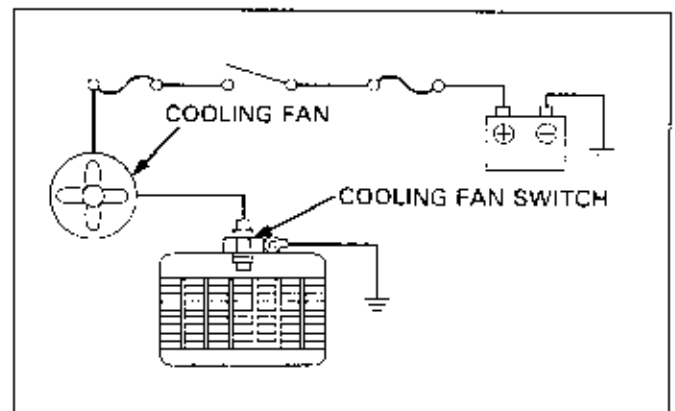

COOLING SYSTEM

RADIATOR CAP

The boiling point of the coolant may be increased by providing a pressure-type cap (hereafter, radiator cap) on the coolant inlet. The radiator cap serves to increase the coolant temperature as well as to retain pressure in the cooling system.

Coolant boiling point (Coolant of 50-50 mixture).

At atmospheric pressure: approximate 100°C (212°F)

Under 12.8 psi (0.9 kg/cm²) pressure:
approximate 125°C (257°F)

▲WARNING

- Wait until the engine is cool before slowly removing the radiator cap. Removing the cap while the engine is hot and the coolant is under pressure may cause serious scalding.

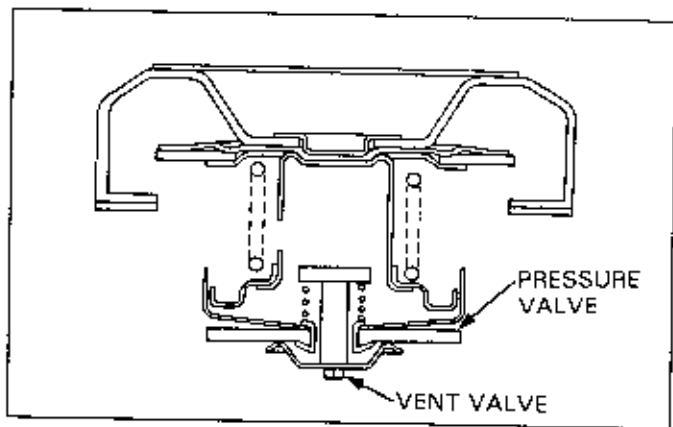

As the coolant temperature increases, the difference in temperature between the coolant and atmosphere becomes greater.

Due to the pressurized system, coolant vapor loss is prevented while the cooling effect is enhanced.

The radiator cap is provided with a pressure valve and vent valve which maintain the pressure in the cooling system at a constant level.

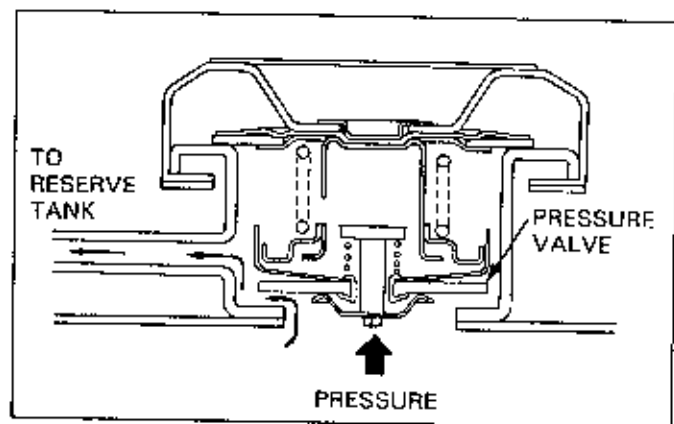

If the pressure in the cooling system is increased due to the increase in coolant temperature, the pressure is kept constant by means of a pressure valve.

If the pressure exceeds the prescribed limit, the pressure valve is opened so that the pressure in the cooling system is regulated by releasing the coolant (whose volume has expanded due to the increase in temperature). The pressure at which the pressure valve begins to open is called the radiator valve opening pressure.

When the coolant temperature is decreased after shutdown of the engine and the cooling system pressure is reduced (with the coolant volume contracted), the vent valve is opened by atmospheric pressure and coolant from the reserve tank flows back into the cooling system.

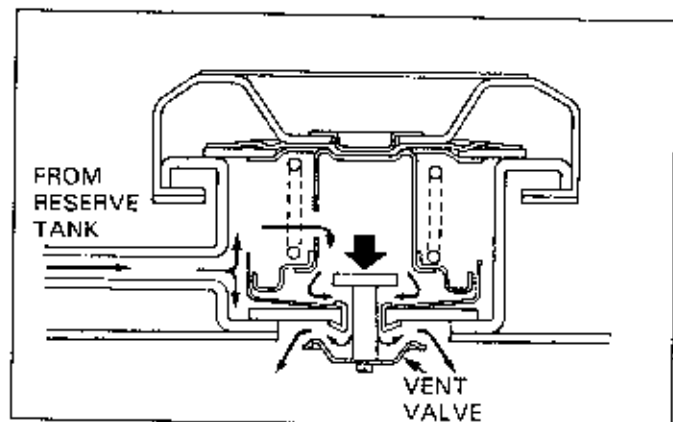

RESERVE TANK

As explained in the preceding paragraph "Radiator Cap", the reserve tank serves to temporarily store the reserve volume of the coolant.

This aids to control the coolant level in the cooling system. The reserve tank is connected to the radiator by means of a siphon tube.

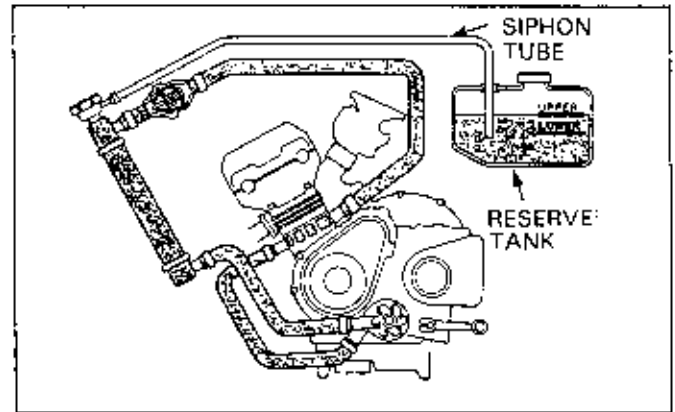

THERMOSTAT

The thermostat is installed between the water jacket of the cylinder head and the radiator.

The thermostat helps warm up the engine by preventing coolant circulation when the temperature of the engine (coolant) is low by closing a valve.

It is an automatic valve designed so that when the engine temperature increases, thermostat wax expands to open the valve, allowing the coolant to circulate through the radiator.

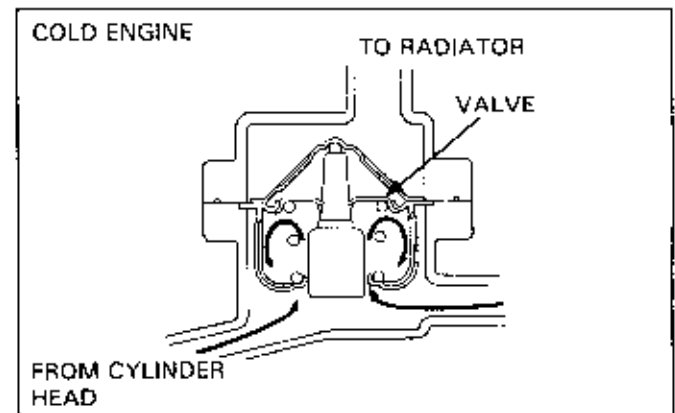

Even if atmospheric temperature varies, the thermostat controls the engine temperature at a constant level.

Leaving the thermostat open allows the coolant to circulate even at low temperatures. This prevents optimum engine operating temperature and leads to overcooling.

Leaving the thermostat closed contributes to overheating, since it prevents coolant circulation and prevents the radiator from dissipating the heat if the engine temperature exceeds the critical limit.

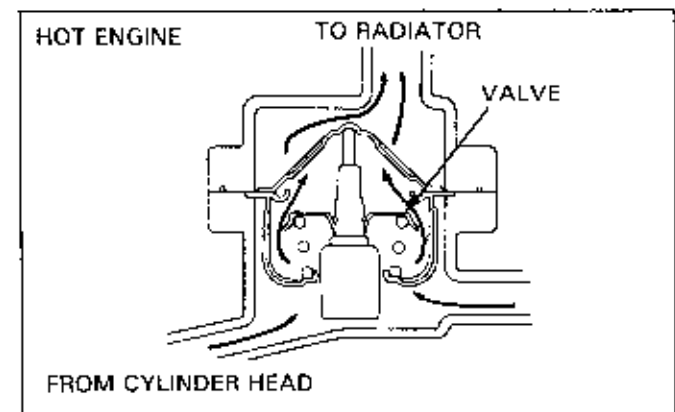

WATER PUMP

The water pump prompts the natural circulation of the coolant in the cooling system, which is carried out by convection. It also feeds the coolant uniformly to the cylinder and cylinder head water jacket so that effective cooling is maintained even if the radiator capacity is reduced.

When the impeller turns, centrifugal force draws the coolant through the water pump inlet and discharges it into the engine's water jacket.

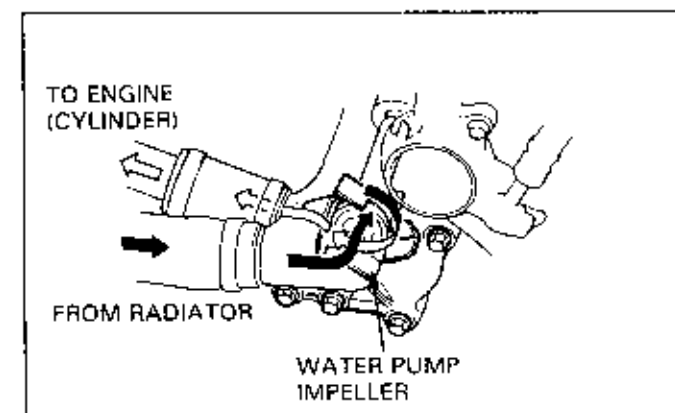

COOLANT

PREPARATION

⚠ WARNING

- Radiator coolant is toxic. Keep it away from eyes, mouth, skin and clothes.
 - If any coolant gets in your eyes, rinse them with water and consult a doctor immediately.
 - If any coolant is swallowed, induce vomiting, gargle and consult a physician immediately.
 - If any coolant gets on your skin or clothes, rinse thoroughly with plenty of water.
- KEEP OUT OF REACH OF CHILDREN

NOTE

- The effectiveness of coolant decreases with the accumulation of rust or if there is a change in the mixing proportion during usage. Therefore, for best performance change the coolant regularly as specified in the maintenance schedule.
- Use coolant designed for use in aluminum engines (ethylene glycol base solution).
- Mix only distilled, low mineral water with the antifreeze.

Mix the distilled water and ethylene glycol base solution with about 5°C (41°F) of tolerance in respect to the minimum temperature.

RECOMMENDED MIXTURE:

50/50 (Distilled water and coolant)

REPLACEMENT

CAUTION

- Wait until the engine is cool before servicing the cooling system. Removing the radiator cap while the engine is hot and the coolant is under pressure may cause serious scalding.

Refill the reserve tank with new coolant.

Remove the coolant reserve tank. Empty the coolant and rinse the inside of the reserve tank.

Remove the radiator cap and drain bolt(s), and drain the coolant.

Reinstall the drain bolt(s).

Refer to the Model Specific manual for drain bolt locations.

Pour the recommended coolant through the radiator filler opening up to the filler neck.

Reinstall the reserve tank and fill it to the upper level line with fresh coolant.

Bleed air from the system.

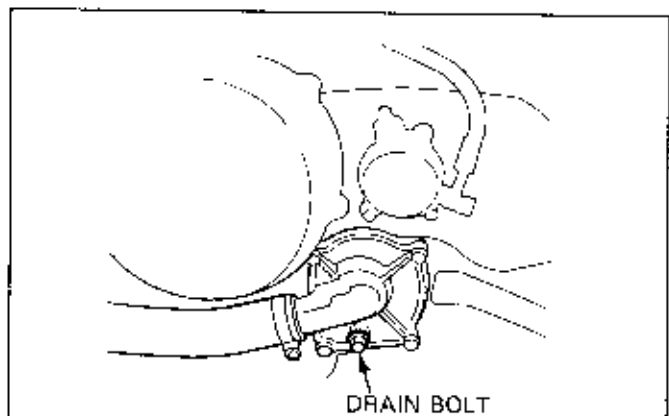
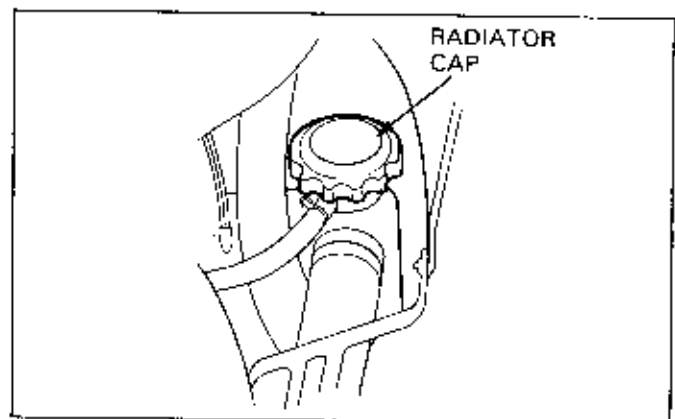
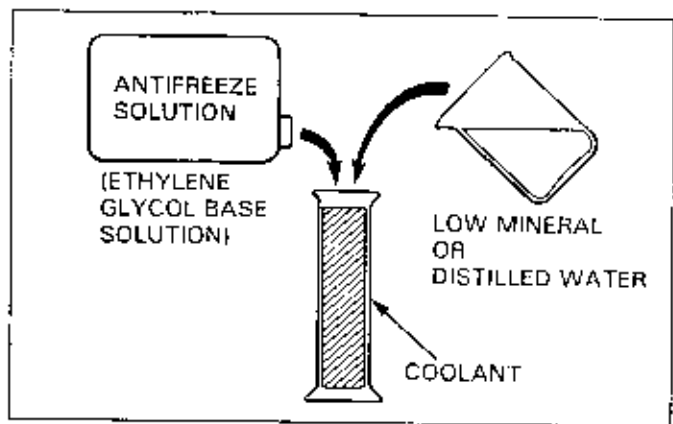

AIR BLEEDING

- Shift the transmission into neutral.
- Start the engine and run it at idle for two to three minutes.
- Snap the throttle 3 - 4 times to bleed air from the system.
- Stop the engine and add coolant up to filler neck.
- Check the coolant level of the reserve tank and fill to the upper level if the level is low.

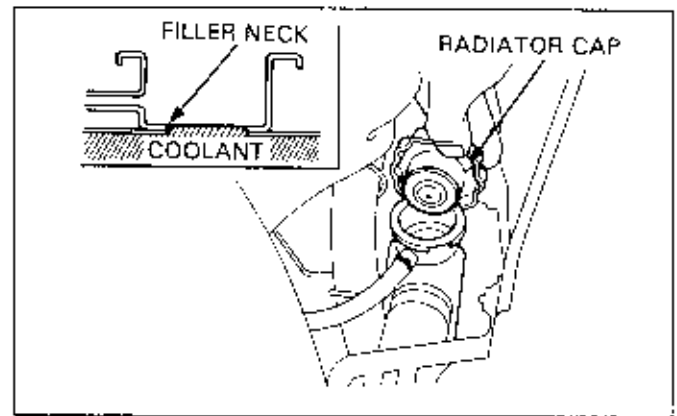

SYSTEM TESTING

HYDROMETER TEST

- Check the coolant gravity using a hydrometer.
- Look for contamination and replace the coolant if necessary.

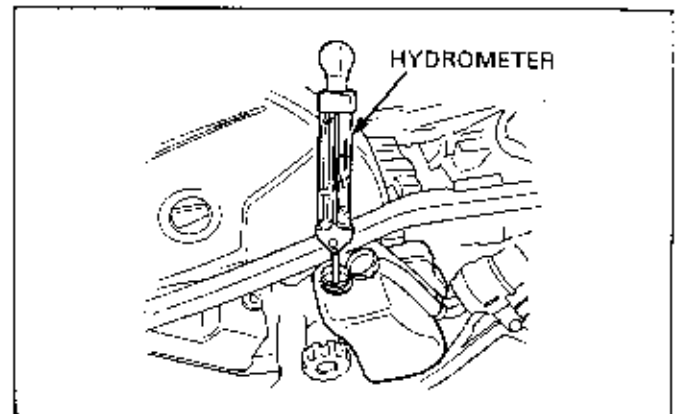

Coolant gravity chart

COOLANT TEMPERATURE °C (°F)	COOLANT RATIO %										
	0 (32)	5 (41)	10 (50)	15 (59)	20 (68)	25 (77)	30 (86)	35 (95)	40 (104)	45 (113)	50 (122)
5	1.009	1.009	1.008	1.008	1.007	1.006	1.005	1.003	1.001	0.999	0.997
10	1.018	1.017	1.017	1.016	1.015	1.014	1.013	1.011	1.009	1.007	1.005
15	1.028	1.027	1.026	1.025	1.024	1.022	1.020	1.018	1.016	1.014	1.012
20	1.036	1.035	1.034	1.033	1.031	1.029	1.027	1.025	1.023	1.021	1.019
25	1.045	1.044	1.043	1.042	1.040	1.038	1.036	1.034	1.031	1.028	1.025
30	1.053	1.052	1.051	1.049	1.047	1.045	1.043	1.041	1.038	1.035	1.032
35	1.063	1.062	1.060	1.058	1.056	1.054	1.052	1.049	1.046	1.043	1.040
40	1.072	1.070	1.068	1.066	1.064	1.062	1.059	1.056	1.053	1.050	1.047
45	1.080	1.078	1.076	1.074	1.072	1.069	1.066	1.063	1.060	1.057	1.054
50	1.086	1.084	1.082	1.080	1.077	1.074	1.071	1.068	1.065	1.062	1.059
55	1.095	1.093	1.091	1.088	1.085	1.082	1.079	1.076	1.073	1.070	1.067
60	1.100	1.098	1.095	1.092	1.089	1.086	1.083	1.080	1.077	1.074	1.071

COOLING SYSTEM

RADIATOR CAP TEST

Test the radiator cap using the cooling system tester.
Replace the cap if the relief pressure is too high or too low, or if the cap does not hold the specified pressure for at least 6 seconds.

NOTE

- Before installing the cap on the tester, wet the sealing surfaces with clean water.

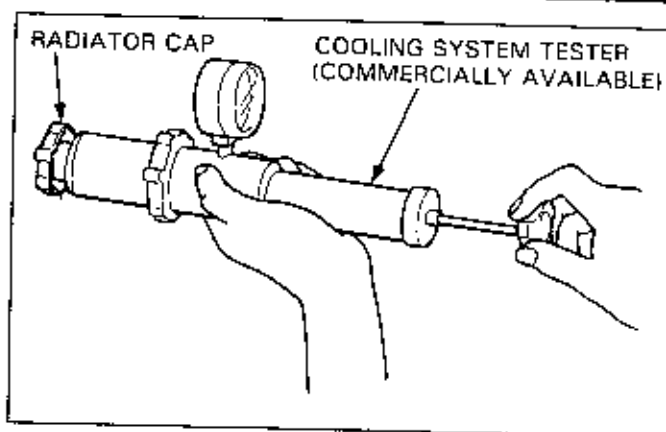

SYSTEM PRESSURE TEST

CAUTION

- Exceeding the radiator cap relief pressure can damage cooling system components.

Check that the system holds the specified pressure for at least 6 seconds.

If the system will not hold the specified pressure, check the following and correct as necessary.

- All hose and pipe connections
- Water pump installation
- Water pump seal (for leakage)

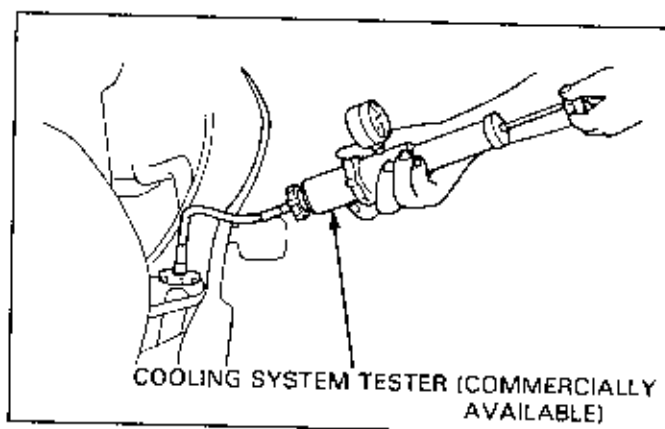

THERMOSTAT

Remove the thermostat (refer to the Model Specific manual).

Inspect the thermostat visually for damage.

Suspend the thermostat in heated water to check its operation.

NOTE

- Do not let the thermostat or thermometer touch the pan, or you will get false readings.
- Replace the thermostat if valve stays open at room temperature, or if it responds at temperatures other than those specified.
- Check for the correct valve lift temperature with the water heated to operating temperature for 5 minutes. Refer to the Model Specific manual for the specific temperature.

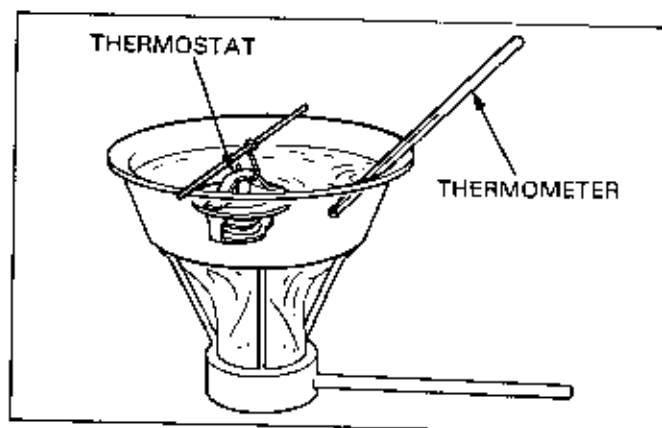

Reinstall the thermostat.

WATER PUMP

MECHANICAL SEAL INSPECTION

Inspect the telltale hole for signs of coolant leakage.

If there is leakage, the mechanical seal is defective and must be replaced.

See the Model Specific manual for mechanical seal replacement procedures.

If the mechanical seal is the built in type, the water pump must be replaced as an assembly.

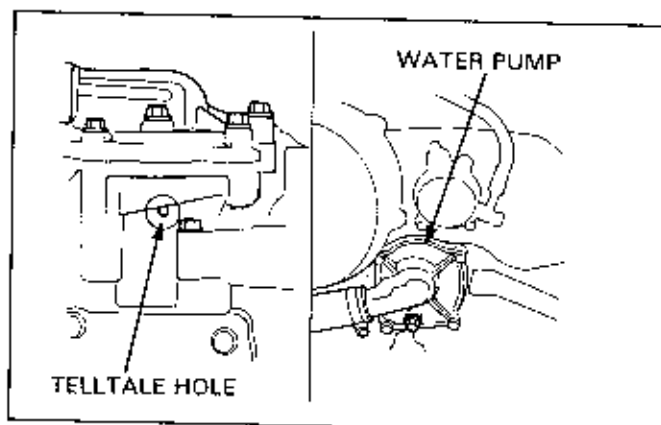

REPLACEMENT

Drain the engine oil and coolant.

Remove the water pump mounting bolts.

Disconnect the water hoses and by-pass tube, then remove the water pump.

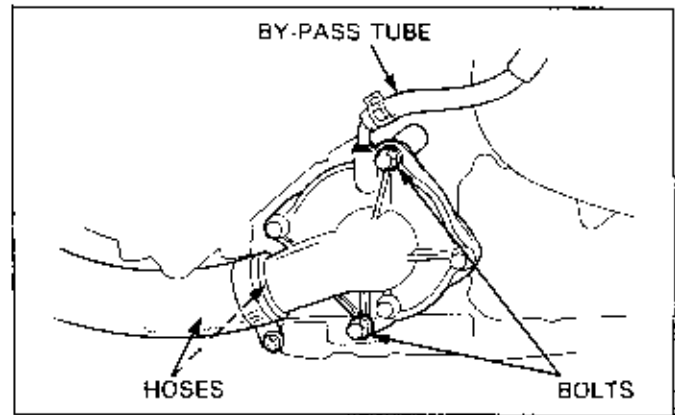

Remove the bolts and separate the pump cover from the body.

Replace the water pump with new one.

Install a new O-ring into the groove in the pump cover, then install the cover on the pump.

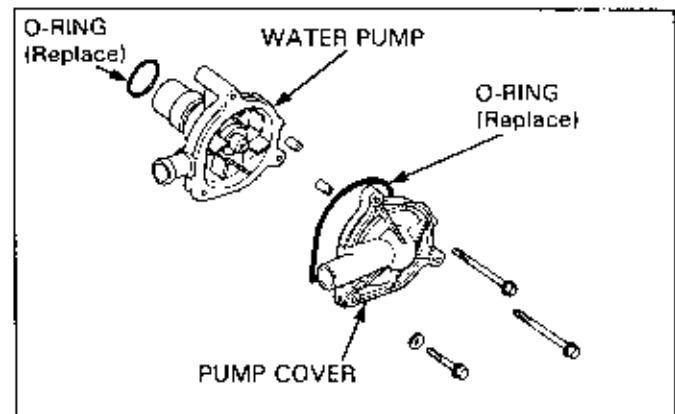

Install a new O-ring onto the water pump.

Align the water pump shaft groove with the water pump drive shaft and install the water pump.

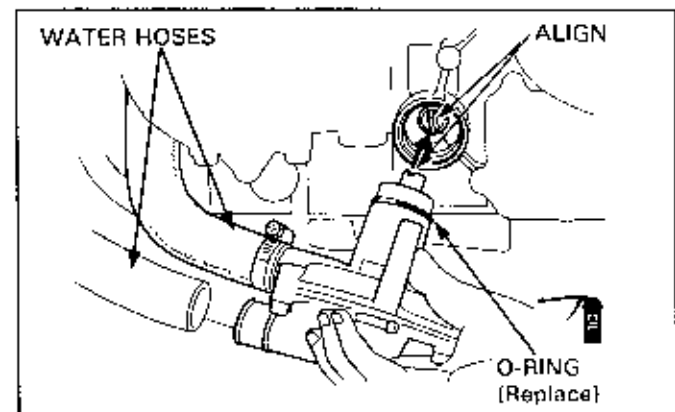

Tighten the pump mounting bolts.

Connect the water hoses and secure the bands and clamp.

Fill the cooling system and add the recommended engine oil.

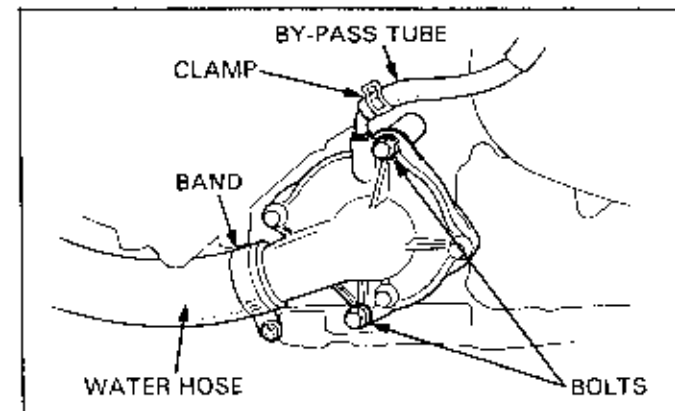

6. EXHAUST SYSTEM

SERVICE INFORMATION

6-1

SYSTEM DESCRIPTION

6-2

TROUBLESHOOTING

6-1

SERVICE INFORMATION

▲WARNING

• **Serious burns may result if the exhaust system is not allowed to cool before components are removed or serviced.**

- Always replace the exhaust pipe gasket when removing the exhaust pipe from the engine.
- Note the positions of the clamps installed between the exhaust pipe and muffler, the tab on the clamp should align with the groove on the muffler.
- When installing the exhaust system, install all the fasteners loosely. Always tighten the exhaust clamp nut first, then tighten the mounting fasteners. If you tighten the mounting fasteners first, the exhaust pipe may not seat properly.
- Always inspect the exhaust system for leaks after installation.

TROUBLESHOOTING

Excessive exhaust noise

- Broken exhaust system
- Exhaust gas leaks

Poor performance

- Deformed exhaust system
- Exhaust gas leaks
- Clogged muffler

SYSTEM DESCRIPTIONS

The exhaust system serves other function in addition to discharging the exhaust gas.

Since the exhaust gas discharged from the exhaust port is pressurized and very hot, it swells suddenly and produces a loud noise if it is discharged from the exhaust port directly into the atmosphere. It also lowers the exhaust efficiency as the gas is diffused from the exhaust port. To prevent the above problems, the exhaust gas is drawn from the exhaust port into the muffler to be swelled and is discharged into the atmosphere after its temperature and pressure are lowered. By varying the sizes and diameters of sections of the exhaust system, the air/fuel mixture can be drawn into the cylinder more effectively. This is called the EXHAUST PULSE SCAVENGE EFFECT. Utilizing this effect in exhaust system design results in significant improvements in engine performance, especially on 2-stroke engines.

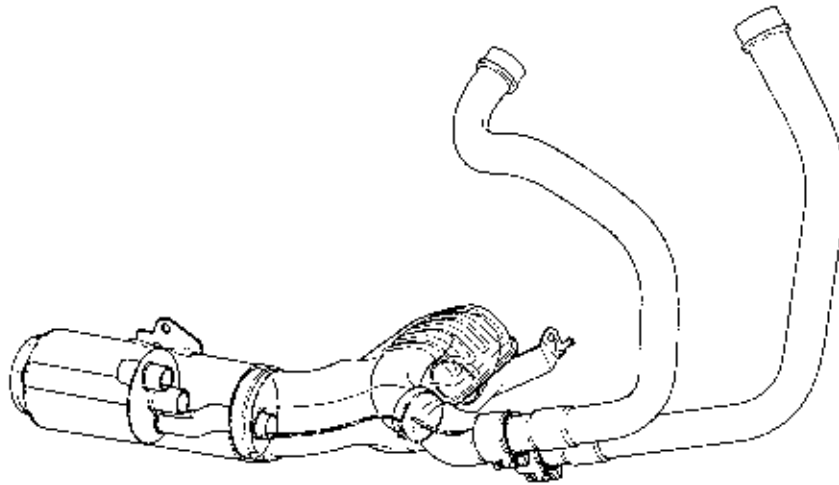

EXHAUST PULSE SCAVENGE EFFECT

When the exhaust valve (or port) opens with the engine on the exhaust stroke, the exhaust gas flows rapidly from the exhaust port into the muffler. At the end of the exhaust stroke, the gas flow slows down, but due to the inertia of liquid mass, pressure in the cylinder goes down below the atmospheric pressure; in other words, negative pressure is applied to the cylinder for a short time. As the intake valve (or scavenge port) opens, the air/fuel mixture quickly drawn into the cylinder.

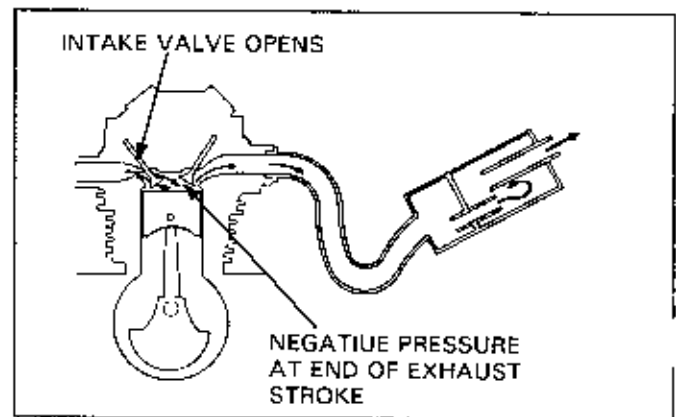

The discharged gas flows through the muffler forming a high speed pressure wave. Due to the inertia of liquid mass, negative pressure is applied to the exhaust port where the pressure wave had passed. When the exhaust valve (or port) opens on the next exhaust stroke, the exhaust gas is drawn out by the negative pressure, and the exhaust efficiency is improved.

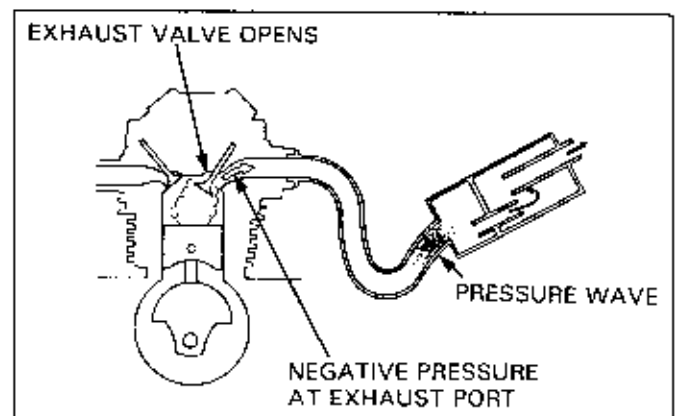

On 2-stroke engines, there is the possibility that the air/fuel mixture that was scavenged just before the end of the exhaust stroke may leak out to some degree and be discharged into the exhaust port.

The gas is discharged into the muffler, forming a high pressure wave. This pressure wave impacts against the taper at the end of the muffler, rebounds, and applies a positive pressure to the exhaust port. The air/fuel mixture that was about to be discharged before the exhaust port closes is thus forced back into the cylinder and the exhaust pulse scavenge effect is improved.

Since the pressure wave cycle changes in accordance with the change in engine speed, the exhaust pulse scavenge effect is not always as effective as it could be at all engine speeds.

The exhaust pulse scavenge effect is regulated to a certain range of engine speed. Therefore, the exhaust system is designed to be most effective and most suitable for each model, depending on its intended use.

Note that if the exhaust system is deformed due to denting or exhaust gas leakage, it can effect the exhaust pulse and result in a drop in engine horsepower.

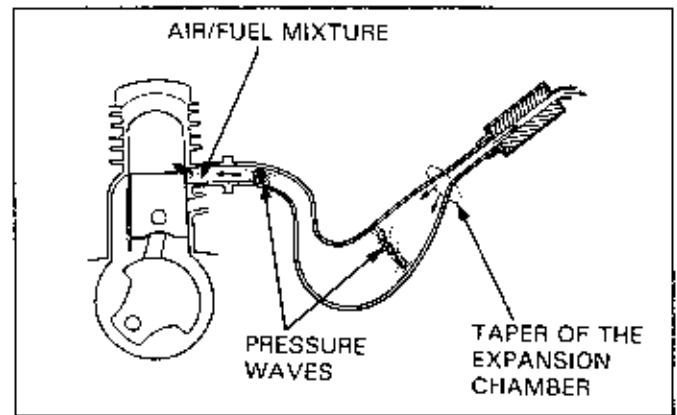

COMMON EXHAUST PIPE

The muffler of the conventional 4-stroke multicylinder engine uses an independent pipe for each cylinder, but most recent models adopt a common exhaust pipe for all cylinders.

The new system features a system in which the exhaust pipes join in the exhaust chamber, and another in which the exhaust pipes are directly joined. In both systems gas pressures exhausted from individual cylinders intermingle. The pulse wave in the muffler, generated by the staggered combustion in adjoining cylinders, promotes the "pulse scavenge effect", which increases exhaust energy absorption and reduces exhaust noise effectively. The resulting smaller muffler has a decreased capacity and increased silencing capability, due to the reduced weight and decreased volume.

The method of exhaust pipe connection depends on the cylinder arrangement or the required engine characteristics. For example, an inline four cylinder engine can be connected with "4-into-1" system or "4-2-2" system etc.

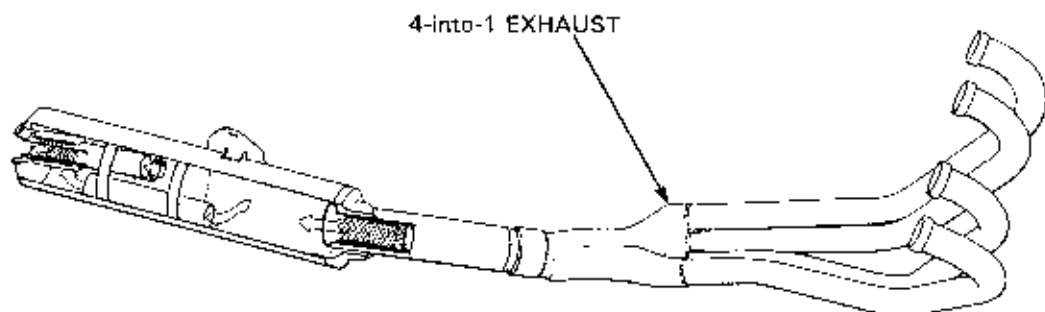

7. EMISSION CONTROL SYSTEMS

SERVICE INFORMATION	7-1	SYSTEM INSPECTIONS	7-5
TROUBLESHOOTING	7-1	EMISSION CONTROL INFORMATION LABELS	7-9
SYSTEM DESCRIPTIONS	7-2		

SERVICE INFORMATION

CAUTION

- To prevent damage, be sure to remove the diaphragms before cleaning air and fuel passages with compressed air.
- All hoses used in the secondary air supply and evaporative emission control systems are numbered for identification. When connecting one of these hoses, compare the hose number with the Vacuum Hose Routing Diagram Label (Refer to the Model Specific manual).
- Refer to the Model Specific manual for emission control system application.

TROUBLESHOOTING

Engine stalls, hard to start, rough idling

- Purge control valve faulty
- Air vent control valve faulty
- Hoses in the emission control system faulty

Afterburn when engine braking is used

- Secondary air supply system faulty
- Hoses in emission control system faulty

Poor performance (driveability) and poor fuel economy

- Faulty air vent control valve
- Damaged/misconnected emission control system hoses

SYSTEM DESCRIPTIONS

The U.S. Environmental Protection Agency and California Air Resources Board (CARB) require manufacturers to certify that their motorcycles comply with applicable exhaust emissions standards during their useful life, when operated and maintained according to the instructions provided, and that motorcycles built after January 1, 1983 comply with applicable noise emission standards for one year or 6,000 km (3,730 miles) after the time of sale to the ultimate purchaser, when operated and maintained according to the instructions provided. Compliance with the terms of the Distributor's Warranties for Honda Motorcycle Emission Control Systems is necessary in order to keep the emissions system warranty in effect.

SOURCE OF EMISSIONS

The combustion process produces carbon monoxide and hydrocarbons. Control of hydrocarbons is very important because, under certain conditions, they react to form photochemical smog when subjected to sunlight. Carbon monoxide does not react in the same way, but it is toxic.

Honda Motor Co., Ltd. utilized lean carburetor settings as well as other systems, to reduce carbon monoxide and hydrocarbons.

CRANKCASE EMISSION CONTROL SYSTEM

The crankcase emission control system routes crankcase emissions through the air cleaner and into the combustion chamber. Condensed crankcase vapors are accumulated in an air/oil separator and drain tube which must be emptied periodically. Refer to the Maintenance Schedule for each model. The drain tube needs to be checked for oil accumulation more frequently if the machine has been consistently ridden at high speeds or in rain.

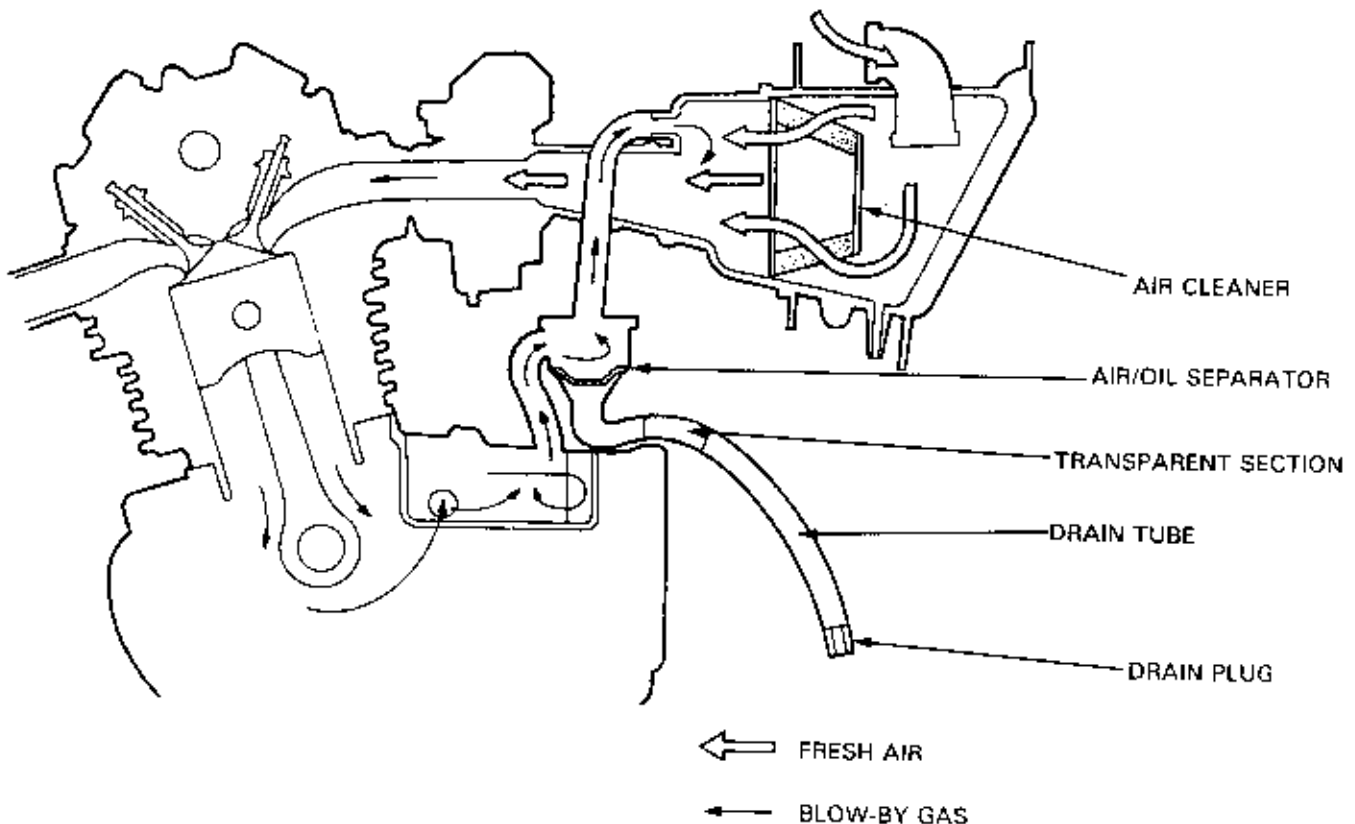

EXHAUST EMISSION CONTROL SYSTEM (SECONDARY AIR SUPPLY SYSTEM)

The exhaust emission control system is composed of lean carburetor settings and no adjustment should be made except idle speed adjustment with the throttle stop screw.

The exhaust emission control system consists of a secondary air supply system which introduces filtered air into the exhaust gases in the exhaust port. Fresh air is drawn into the exhaust port whenever there is a negative pressure pulse in the exhaust system. This charge of fresh air promotes burning of the unburned exhaust gases and changes a considerable amount of hydrocarbons and carbon monoxide into relatively harmless carbon dioxide and water.

A reed valve prevents reverse air flow through the system. The air injection control valve reacts to high intake manifold vacuum and will cut off the supply of fresh air during engine deceleration, thereby preventing afterburn in the exhaust system.

No adjustments to the secondary air supply system should be made, although periodic inspection of the components is recommended.

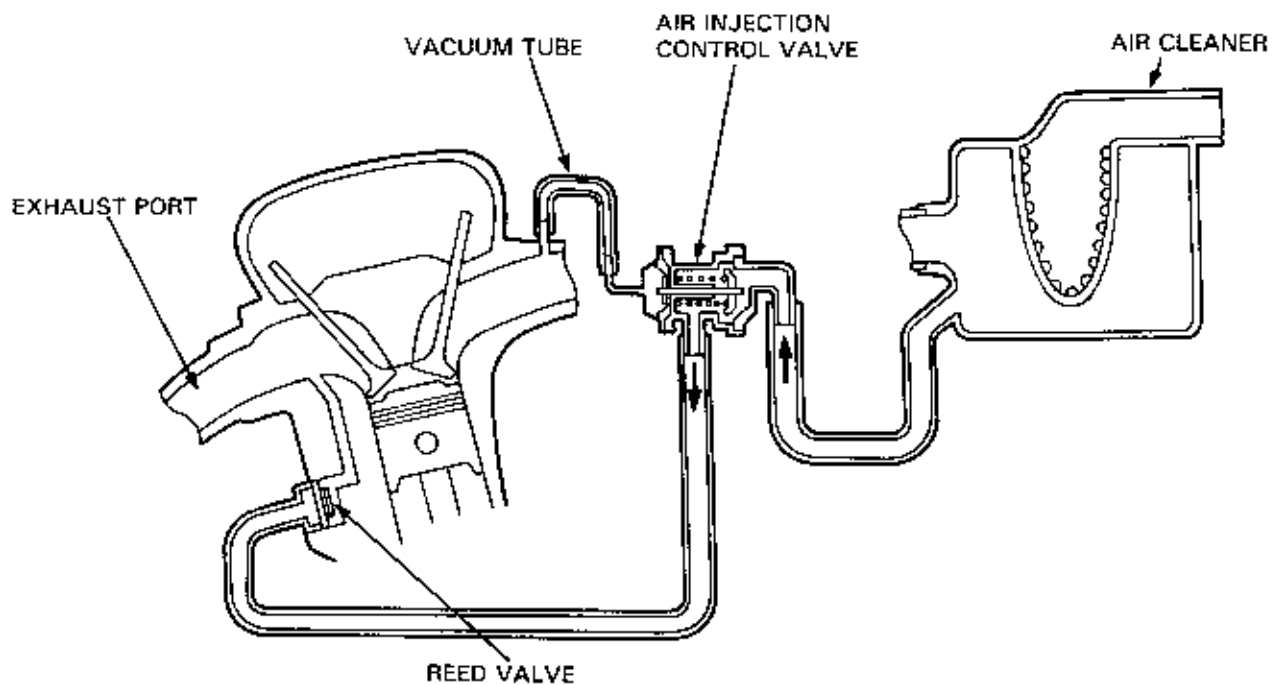

EMISSION CONTROL SYSTEMS

EVAPORATIVE EMISSION CONTROL SYSTEM (California model only)

All Honda motorcycles and scooters sold in California for street use comply with the California Air Resources Board requirements for evaporative emission regulations.

Fuel vapor from the fuel tank and carburetors is routed into the charcoal canister where it is absorbed and stored while the engine is stopped. When the engine is running and the purge control diaphragm valve is open fuel vapor in the charcoal canister is drawn into the engine through the carburetor. At the same time, the air vent control valve is open and air is drawn into the carburetor through the valve.

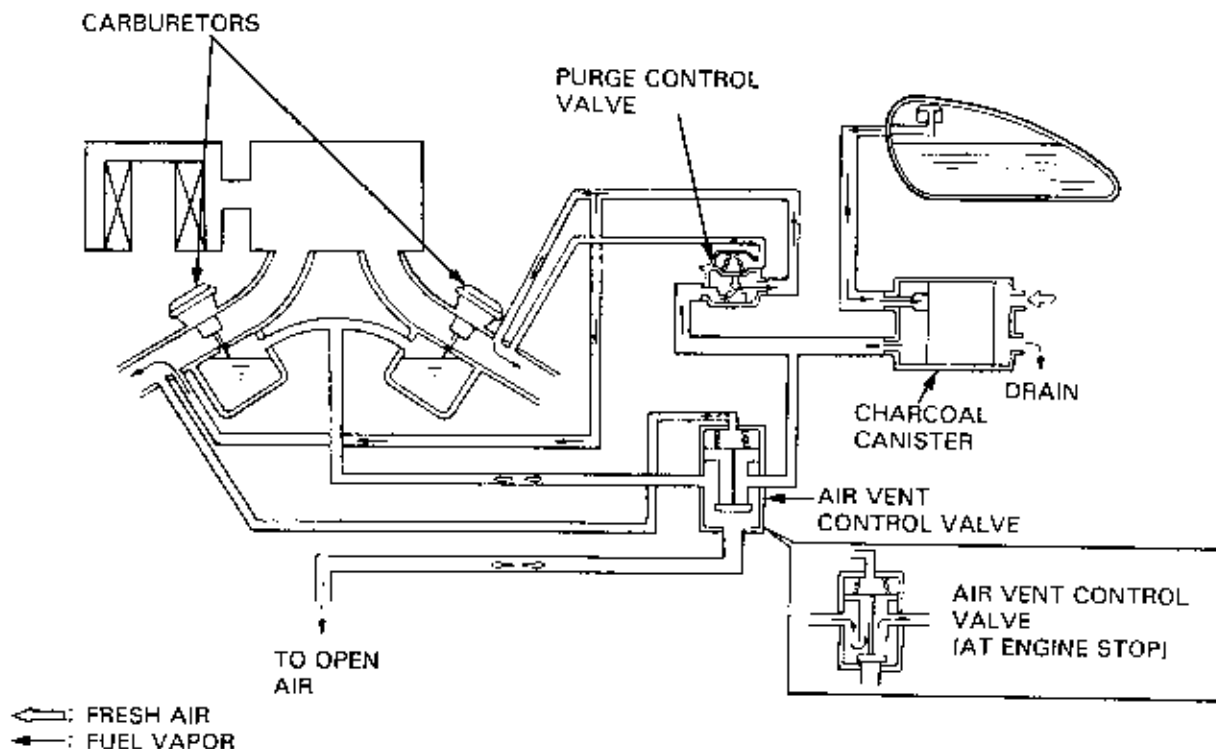

NOISE EMISSION CONTROL SYSTEM

TAMPERING WITH THE NOISE CONTROL SYSTEM IS PROHIBITED: Federal law prohibits the following acts or the causing thereof: (1) The removal or rendering inoperative by any person, other than for purposes of maintenance, repair or replacement, of any device or element of design incorporated into any new vehicle for the purpose of noise control prior to its sale or delivery to the ultimate purchaser or while it is in use; or (2) the use of the vehicle after such device or element of design has been removed or rendered inoperative by any person.

AMONG THOSE ACTS PRESUMED TO CONSTITUTE TAMPERING ARE THE ACTS LISTED BELOW:

1. Removal of, or puncturing the muffler, baffles, header pipes or any other component which conducts exhaust gases.
2. Removal of, or puncturing of any part of the intake system.
3. Lack of proper maintenance.
4. Replacing any moving parts of the vehicle, or parts of the exhaust or intake system, with parts other than those specified by the manufacturer.

SYSTEM INSPECTIONS

EVAPORATIVE EMISSION CONTROL SYSTEM (California model only)

Check the system hoses for deterioration, clogging, damage, and loose joints and connections.

Replace any hose that shows signs of damage or deterioration.

Check the canister for cracks or damage.

PURGE CONTROL VALVE (PCV)

NOTE

- The purge control valve should be inspected if hot restart is difficult.

Disconnect the PCV hoses from their connections and remove the PCV from its mount. Refer to the vacuum hose routing diagram label for hose connections.

Connect a vacuum pump to the hose that goes to the vacuum tube fitting.

Apply the specified vacuum to the PCV.

S-TROL

VACUUM PUMP

ST-AH-260-MC7
(U.S.A. only)

SPECIFIED VACUUM: 250 mm (9.8 in) Hg

The specified vacuum should be maintained. Replace the PCV if vacuum is not maintained.

Remove the vacuum pump and connect it to the hose fitting (PCV output port) that goes to the carburetor(s).

NOTE

- If the PCV has two hose fittings that go to the carburetor(s), connect the blocked tube onto the other fitting to prevent air leaks.

Apply the specified vacuum to the PCV.

SPECIFIED VACUUM: 250 mm (9.8 in) Hg

The specified vacuum should be maintained. Replace the PCV if vacuum is not maintained.

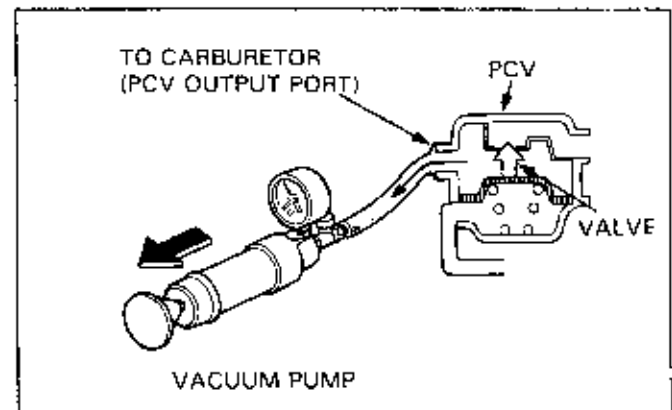
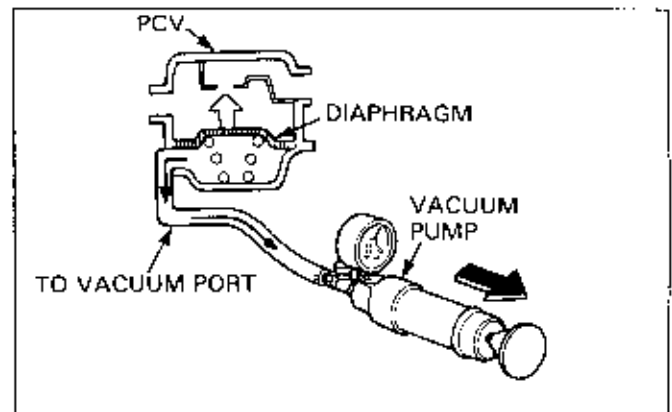

EMISSION CONTROL SYSTEMS

Connect a pressure pump to the hose fitting that goes to the charcoal canister.

NOTE

- If the PCV has two hose fittings that go to the charcoal canister, connect the blocked tube onto the other fitting to prevent air leaks.

While applying the specified vacuum to the PCV hose that goes to the vacuum port, pump air through the canister hose. Air should flow through the PCV and out the hose that goes to the carburetor. Replace the PCV if air does not flow out.

5 Tool

PRESSURE PUMP

ST-AH-255-MC7
(U.S.A. only)

CAUTION

- Damage to the purge control valve may result from use of a high pressure air source. Use a hand-operated air pump only.

Remove the pump, install the PCV on its mount, route and reconnect the hoses according to the vacuum hose routing diagram label.

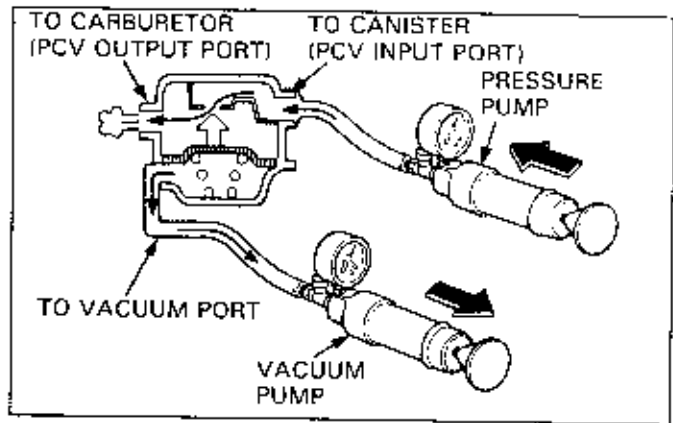

AIR VENT CONTROL VALVE (AVCV)

NOTE

- The air vent control valve should be inspected if engine restart is difficult.

Disconnect the AVCV hoses from their connections and remove the AVCV from its mount. Refer to the vacuum hose routing diagram label for hose connections.

Connect a vacuum pump to the hose that goes to the vacuum tube fitting.

5 Tool

VACUUM PUMP

ST-AH-260-MC7

Apply the specified vacuum to the AVCV.

SPECIFIED VACUUM: 250 mm (9.8 in) Hg

The specified vacuum should be maintained. Replace the AVCV if vacuum is not maintained.

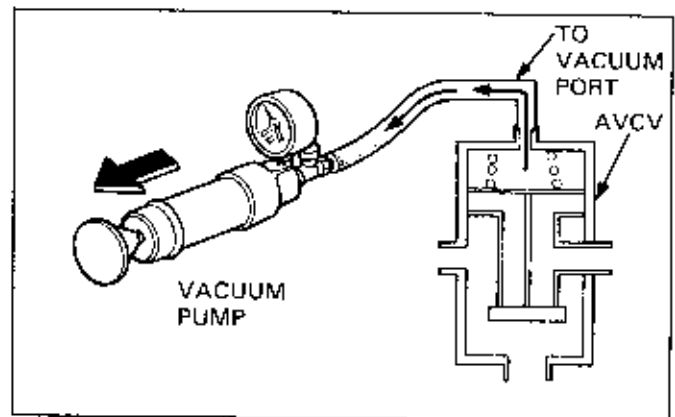

Connect the vacuum pump to the air vent fitting on the AVCV that goes to open air.

NOTE

- If the AVCV has two hose fittings that go to open air, connect the blocked tube onto the other fitting to prevent air leaks.

Apply vacuum to the AVCV. The vacuum should hold steady. Replace the AVCV if vacuum leaks.

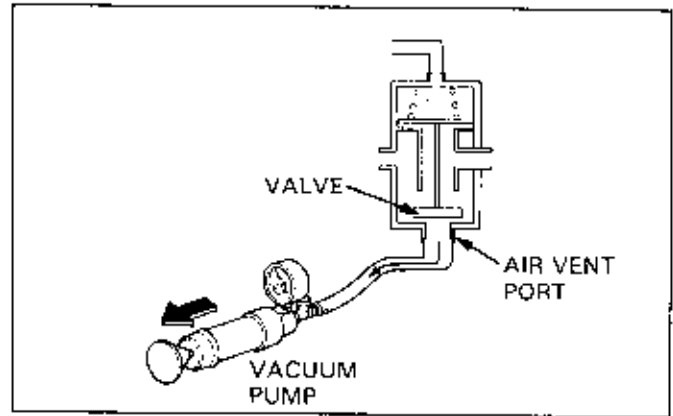

Connect the vacuum pump to the hose that goes to the vacuum tube fitting.

STOOL

VACUUM PUMP

ST-AH-260-MC7
(U.S.A. only)

Connect the pressure pump to the air vent fitting on the AVCV that goes to open air.

STOOL

PRESSURE PUMP

ST-AH-255-MC7
(U.S.A. only)

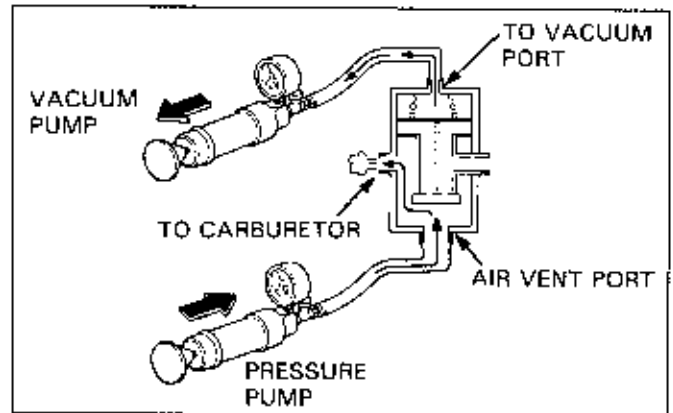

NOTE

- If the AVCV has two hose fittings that go to open air, connect the blocked tube onto the other fitting to prevent air leaks.

While applying the vacuum to the AVCV hose that goes to the vacuum tube fitting, pump air through the air vent fitting. Air should flow through the AVCV and out the hose that goes to the carburetor.

CAUTION

- Damage to the air vent control valve may result from use of a high pressure air source. Use a hand-operated air pump only.

Plug the hose that goes to the carburetor.

NOTE

- If the AVCV has two hose fittings that go to open air, connect the blocked tube onto the other fitting to prevent air leaks.

While applying vacuum to the AVCV hose that goes to the vacuum tube fitting, apply air pressure to the air vent fitting.

It should hold steady.

Replace the AVCV if pressure is not retained.

Remove the pumps, install the AVCV on its mount, route and reconnect the hoses according to the vacuum hose routing diagram label.

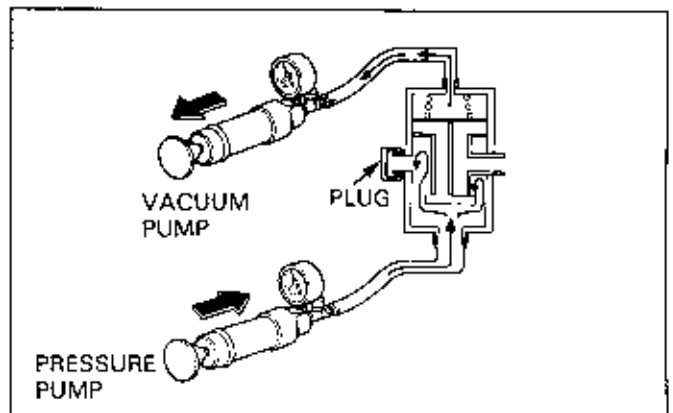

EMISSION CONTROL SYSTEMS

SECONDARY AIR SUPPLY SYSTEM

Start the engine and warm it up to operating temperature.

Stop the engine and remove the air cleaner element.

Check that the secondary air intake ports are clean and free of carbon deposits.

Check the reed valve in the secondary air passage if the ports are carbon fouled.

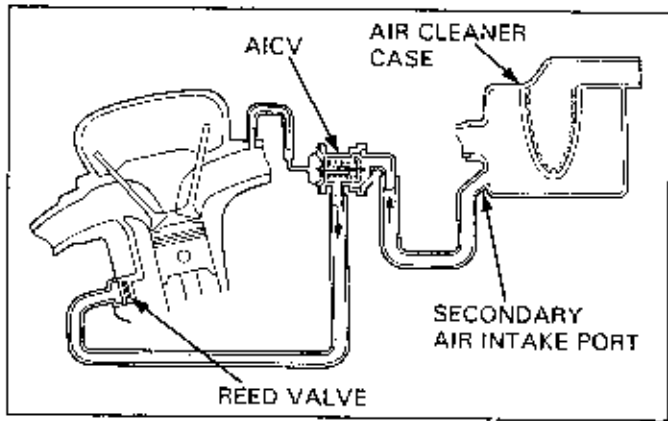

Disconnect the air cleaner-to-air injection control valve hose from the air cleaner case.

Remove the vacuum tube from the carburetor intake pipe; install a plug to keep air from entering.

Connect a vacuum pump to the vacuum hose.

 TOOL

VACUUM PUMP

ST-AH-260-MC7
(U.S.A. only)

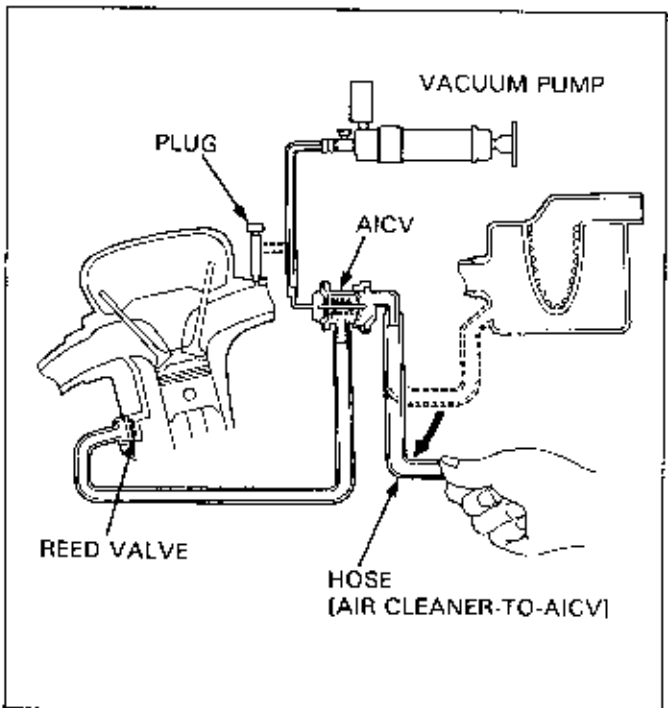

Start the engine and open the throttle slightly to be certain that air is sucked in through the air cleaner-to-AICV hose.

If air is not drawn in, check the air cleaner-to-AICV hose and vacuum hose for clogging.

With the engine running, gradually apply vacuum to the vacuum hose.

Check that the air intake port stops drawing air, and that the vacuum does not bleed.

SPECIFIED VACUUM: Refer to the Model Specific manual.

If air is still drawn in, or if the specified vacuum is not maintained, install a new AICV.

If afterburn occurs on deceleration, even when the secondary air supply system is normal, check the slow air cutoff valve for correct vacuum operation.

REED VALVE

NOTE

- Certain types of secondary air supply systems have the reed valve built in the AICV. Refer to the Model Specific manual for reed valve location.

Remove the reed valve covers and reed valves.

Check the reeds for damage or fatigue, and replace if necessary.

Install a new reed valve if the seat rubber is cracked or damaged, or if there is clearance between the reed and seat.

CAUTION

- Disassembling or bending the reed stopper or reed valve will damage it.
- Replace the reed valve as a unit if the stopper, reed, or seat is faulty.

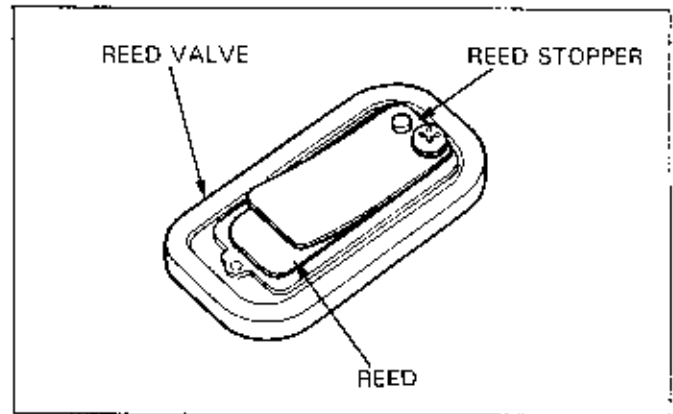

EMISSION CONTROL INFORMATION LABELS

Labels for the emission control system consist of three kinds of information labels as described below.

1. Emission control information label
 - Gives basic tune-up specifications.
2. Emission control information update label
 - After making a high altitude carburetor adjustment, attach this label at the specified location. Instructions for obtaining the update label are given in Service Letter No. 132.
3. Vacuum hose routing diagram label (California model only)
 - Route the vacuum hoses as shown on this label. On after '85 models, all hoses used in the secondary air supply and evaporative emission systems are numbered for identification, so compare the hose number with this label when connecting one of these hoses.

NOTE

- Refer to the Model Specific manual for the location of each label.

EXAMPLE:

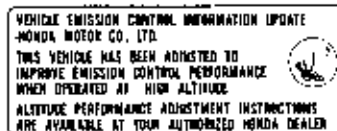

8. FUEL SYSTEM

SERVICE INFORMATION	8-1	FUEL AUTO VALVE	8-8
TROUBLESHOOTING	8-2	CARBURETOR DISASSEMBLY/ INSPECTION	8-9
SYSTEM DESCRIPTION	8-3	CARBURETOR ASSEMBLY	8-14
ACCELERATOR PUMP	8-7	PILOT (OR AIR) SCREW ADJUSTMENT	8-18
AIR CUT-OFF VALVE	8-7	ACCELERATOR PUMP ADJUSTMENT	8-24
REED VALVE	8-7	HIGH ALTITUDE ADJUSTMENT	8-24
FUEL LINE	8-8		

SERVICE INFORMATION

⚠ WARNING

- Gasoline is extremely flammable and is explosive under certain conditions.

- Work in a well ventilated area. Smoking or allowing flames or sparks in the work area or where gasoline is stored can cause a fire or explosion.

CAUTION

- Bending or twisting the control cables will impair smooth operation and could cause the cables to stick or bind, resulting in loss of vehicle control.
- Be sure to remove the diaphragms before cleaning air and fuel passages with compressed air. The diaphragms might be damaged.

- Refer to Model Specific manual for carburetor and reed valve removal/installation.
- When disassembling fuel system parts, note the locations of the O-rings. Replace them with new ones on reassembly.
- Before disassembling the carburetor, place a suitable container under the carburetor drain bolt loosen the bolt and drain the carburetor.
- After removing the carburetor, wrap the intake port of the engine with a shop towel or cover it with piece of rape to prevent any foreign material from dropping into the engine.

NOTE

- If vehicle is to be stored for more than one month, drain the float bowls. Fuel left in the float bowls may cause clogged jets resulting in hard starting or poor driveability.

FUEL FRESHNESS AND TROUBLESHOOTING

Engine performance is directly related to the quality and freshness of the gasoline consumed. Therefore, it is important to be sure the fuel within the motorcycle, scooter or ATV you are servicing is usable for your testing procedures. You may save valuable troubleshooting time by replacing fuel if its quality or age is in doubt.

Detonation (or pinging) on acceleration is an indication that the fuel is either not of good quality or is too low in octane rating for your application.

Fuel should be no more than six to eight weeks old in the case of a minor performance problem, and no more than three months old in the case of more serious performance problems.

TROUBLESHOOTING

Engine won't start

- No fuel to carburetor
 - Fuel strainer clogged
 - Fuel tube clogged
 - Float valve stuck
 - Float level misadjusted
 - Fuel tank breather tube (or hole) clogged
 - Fuel pump malfunction
 - Fuel auto valve malfunction
- Too much fuel getting to the engine
 - Air cleaner clogged
 - Flooded carburetor
- Intake air leak
- Fuel contaminated/deteriorated
- Slow circuit or bystarter circuit clogged

Lean mixture

- Fuel jets clogged
- Float valve faulty
- Float level too low
- Fuel line restricted
- Carburetor air vent hole (or tube) clogged
- Intake air leak
- Fuel pump malfunction
- Fuel auto valve malfunction
- Vacuum piston faulty (CV type only)
- Throttle valve faulty

Rich mixture

- Choke valve or bystarter valve in ON position
- Float valve faulty
- Float level too high
- Air jets clogged
- Air cleaner element contaminated
- Flooded carburetor

Hesitation during acceleration

- Accelerator pump malfunction

Engine stalls, hard to start, rough idling

- Fuel line restricted
- Ignition malfunction
- Fuel mixture too lean/rich
- Fuel contaminated/deteriorated
- Intake air leak
- Idle speed misadjusted
- Fuel pump malfunction
- Fuel auto valve malfunction
- Air screw or pilot screw misadjusted
- Slow circuit or bystarter circuit clogged
- Float level misadjusted
- Fuel tank breather tube (or hole) clogged
- Air vent control valve faulty
- Hoses of the emission control system faulty
- Purge control valve faulty

Afterburn when engine braking is used

- Air cut-off valve malfunction
- Lean mixture in slow circuit
- Secondary air supply system faulty
- Hose of emission control system faulty

Backfiring or misfiring during acceleration

- Ignition system faulty
- Fuel mixture too lean

Poor performance (driveability) and poor fuel economy

- Fuel system clogged
- Ignition malfunction
- Faulty air vent control valve
- Damaged/misconnected emission control system hoses

SYSTEM DESCRIPTION

CARBURETOR

As the piston begins its descent at the start of the induction phase (the period when the air-fuel mixture is drawn in), pressure in the cylinder drops, causing air to flow from the air cleaner, through the carburetor and into the cylinder. The function of the carburetor is to atomize the fuel and create an air-fuel mixture.

As in the figures on the right, air drawn into the carburetor passes through constriction A, where it gains speed. The constriction is known as the venturi section of the carburetor. This increase in flow speed is accompanied by a fall in pressure in the venturi, which is used to draw off fuel from the outlet. The fuel is atomized as it is drawn into the venturi under the influence of atmospheric pressure, and is mixed with the incoming air.

Carburetors are also equipped with mechanisms for regulation of the air and mixture volumes. A throttle valve is used to regulate the flow of air-fuel mixture, and a choke is included for adjusting the air flow under starting conditions.

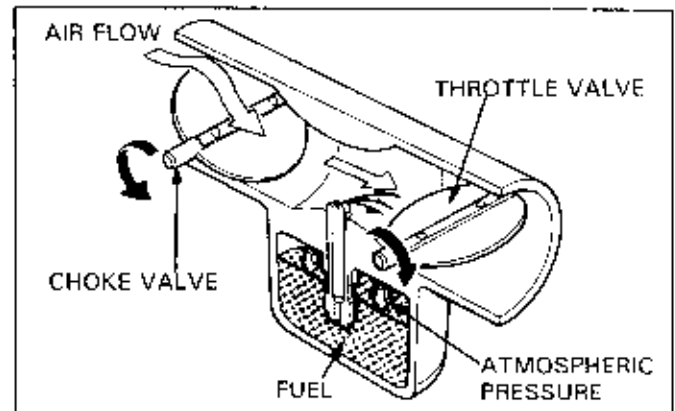
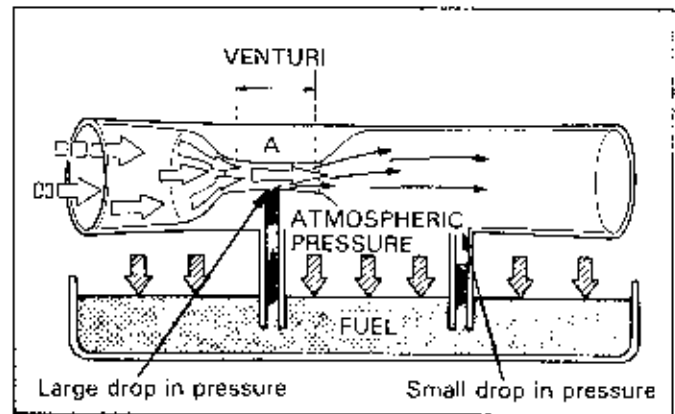

Types of carburetors

Carburetors which alter the diameter of the venturi by throttle valve movement are known as variable venturi types. Honda uses this kind of carburetor on its motorcycles and scooters. Carburetors in which the venturi diameter is not altered are called fixed venturi type carburetors. The variable venturi continuously changes in diameter from low to high speed in proportion to the intake air volume to give smooth aspiration at low speeds and improved power output in the high speed range. Honda motorcycles, scooters and ATVs use one of two variable venturi designs.

1. The constant venturi type (CV): the venturi diameter is altered automatically by vacuum piston that rises and falls to alter the diameter. (The throttle valve is installed as a separate mechanism.)
2. The piston valve or flat slide type: a throttle-controlled piston is used to alter the venturi diameter.

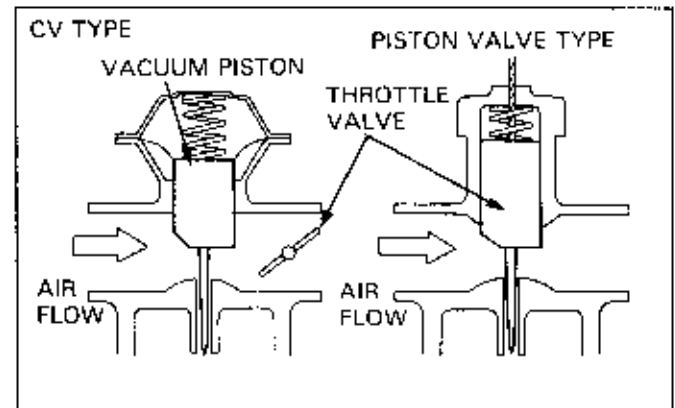

Principle of the vacuum piston operated CV type

As the engine is started and the throttle valve opens, the air flow in the main bore exerts a strong negative pressure on the lower section of the vacuum piston (see Carburetor theory). At this point air is drawn out of the carburetor's vacuum chamber and pressure in the chamber drops. The diaphragm is lifted due to atmospheric pressure, and the vacuum piston is raised. When the throttle valve is closed, air flow in the main bore is obstructed. Pressure returns to that of the atmosphere and the vacuum piston is lowered by spring force.

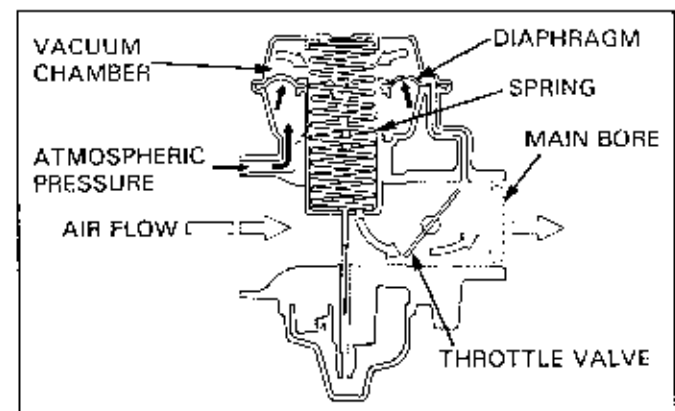

FUEL SYSTEM

Operation of systems

The carburetor is comprised of a starting system which uses either a choke valve or bystarter valve, a float system for fuel supply, and slow and main jet systems etc.

The fuel supply system varies with the degree of throttle opening and regulates fuel according to a slow system at low throttle openings (throttle opening: fully closed to 1/4 open). At medium throttle openings (opening: 1/8—3/4), the main system's jet needle is used to regulate the fuel. The straight section of the jet needle regulates at 1/8—1/2, and the jet needle clip position or jet needle tapered section diameter regulates at 1/4 - 3/4. When the throttle is fully open (actually a range of 1/2—fully open) the fuel is regulated by the main jet of the main system.

Float system

The float chamber holds a constant level of fuel in order that the engine may be provided with a stable supply of the required air-fuel mixture.

As fuel is consumed and the level in the chamber falls, the float and float valve are lowered and the chamber is immediately refilled to a specified level. A rise in fuel level causes the float and its valve to rise, the valve contacts the valve seat and the fuel supply is cut off. This operation is repeated continually as the engine is run.

The float valve contains a spring which lightly depresses the valve so that it does not become dislodged from the seat by vibration when the vehicle is running. To keep the inside of the float chamber at atmospheric pressure, there is a connection to the outside of the carburetor known as the air vent passage.

An overflow tube is provided to vent off any excess fuel to the outside of the carburetor, should the valve and seat become separated due to the intrusion of dirt or other foreign matter.

Starting system

To improve starting when the engine is cold and the fuel is not sufficiently gaseous, the carburetor is equipped with either a choke or bystarter to enrich the mixture.

<Choke system>

A valve is fitted to the air cleaner side of the carburetor. The valve is shut down during starting to reduce the mass flow of air and create an increase in negative pressure in the main bore. The resulting mixture is rich, having a proportionally low volume of air.

The choke valve is provided with a relief mechanism which ensures the optimum opening of the valve under conditions of negative pressure above a certain level, thus preventing the supply of an over-rich mixture to the engine.

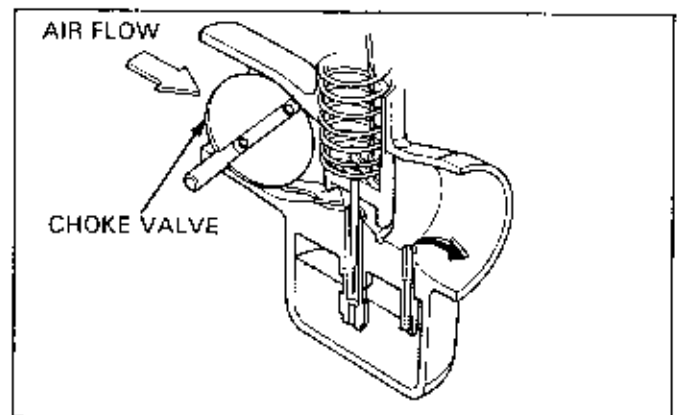
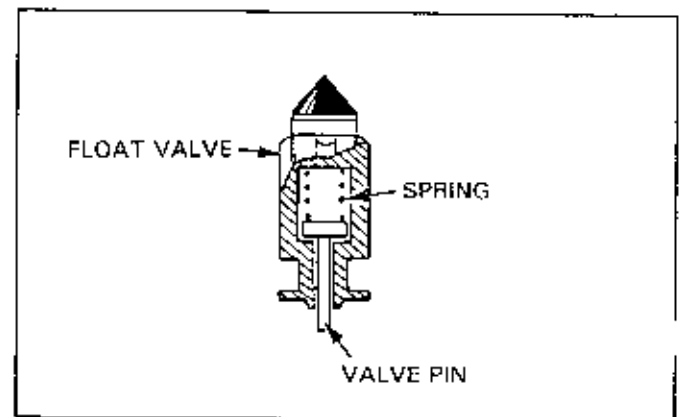
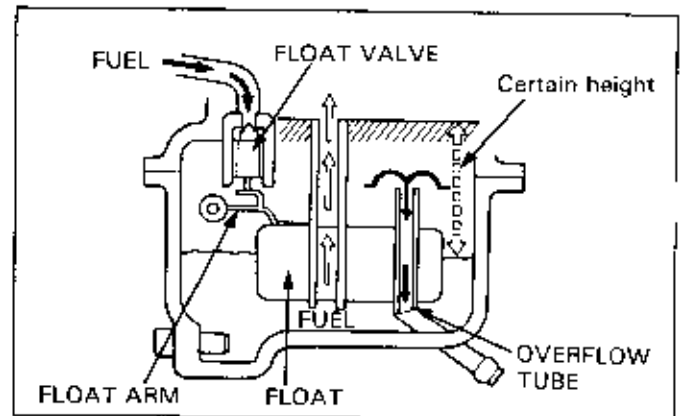
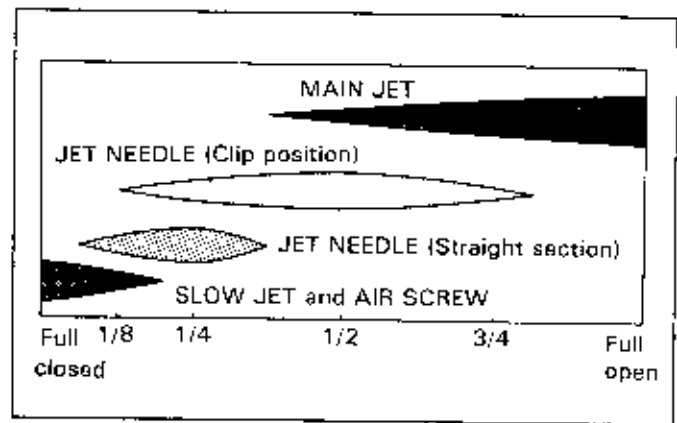

<Bystarter system (manual)>

As the bystarter is opened, the bystarter circuit connects with the main bore. As a vacuum is created in the main bore on starting, air and fuel (drawn from the bystarter air jet and bystarter fuel jet respectively) are injected into the main bore to supply a rich mixture.

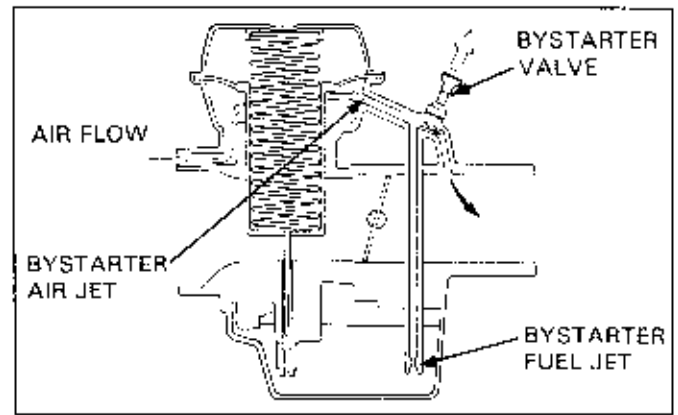

<Auto-bystarter system>

The auto-bystarter PTC is a device for increasing the volume of fuel. It is comprised of components such as a heating element, thermo-wax, a liquid medium, piston and the bystarter valve. The principle of operation is as follows:

When the engine is stopped and there is no production of current from the alternator, the starter valve is maintained in the raised position by a spring. In this position the fuel increase circuit is fully open, ready for supply at any time.

When the engine starts, fuel is supplied through the fuel increase circuit.

At the same time, the alternator sends current to the PTC for heating. The increase in heat is sensed by the thermowax which begins to expand. The movement is transmitted through the liquid medium to the piston, set collar and set spring, and the starter valve is depressed. As the valve is lowered, the jet needle starts to shut off the fuel increase circuit, which, after a few minutes closes fully, ending fuel compensation.

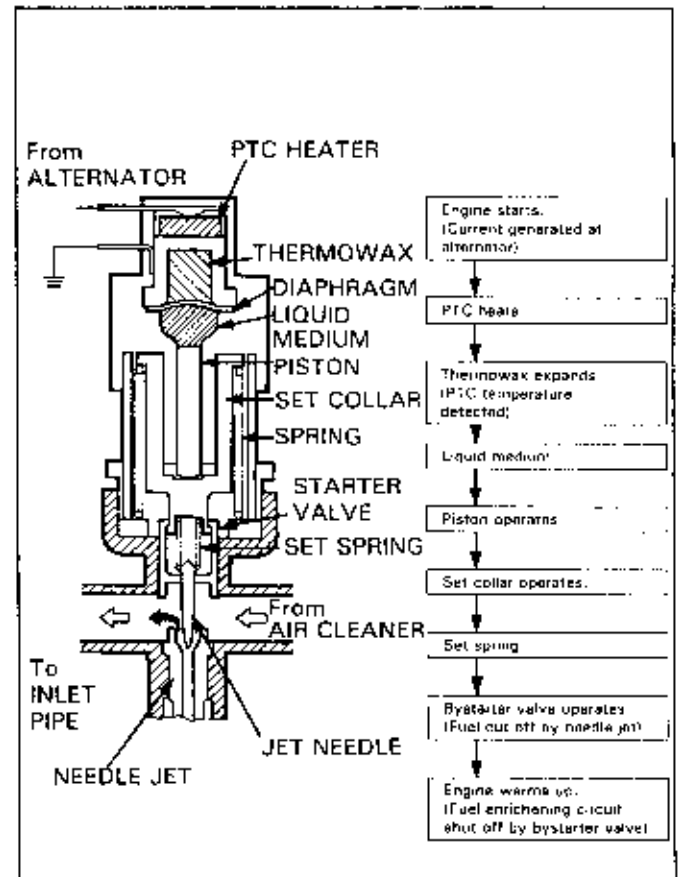

Slow system (low degree of opening)

As the throttle valve is only slightly open at low engine speeds (degree of opening: fully closed - 1/4), pressure on the intake side is low, which allows some residual gas from combustion being sucked back into the intake manifold where it is mixed with fresh charge from the carburetor. The resulting mixture is lean.

Low engine speed is linked with lower compression in the cylinder, resulting in a richer mixture, and it is necessary to raise the combustion velocity.

For this purpose, the engine includes a slow fuel supply system which is separate from the main system.

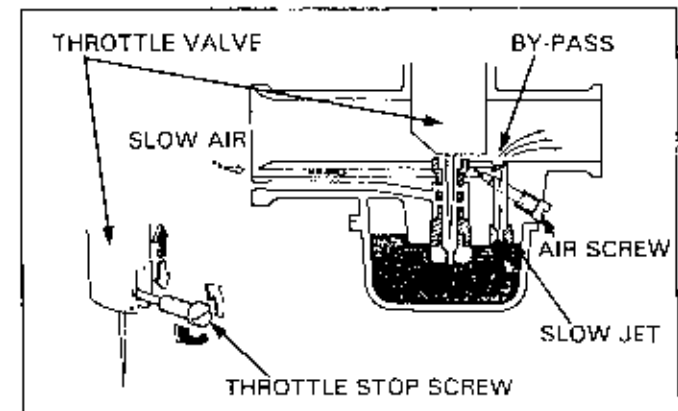

FUEL SYSTEM

Piston valve type throttle valves have a cut-out on the intake side. The larger the cut-out, the greater the volume of air entering and the leaner the mixture.

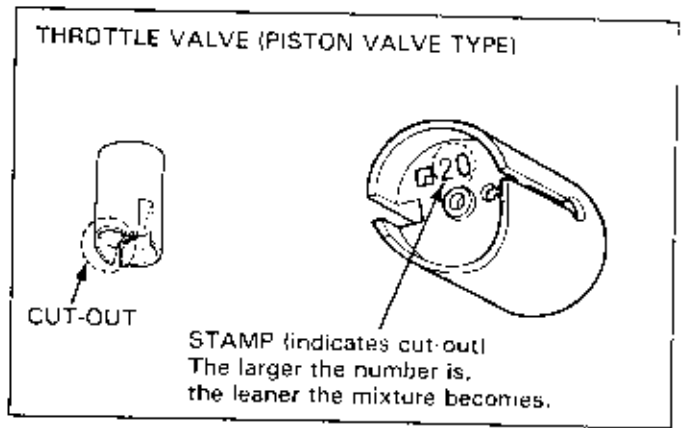

Main system (medium throttle opening)

When the throttle valve is opened to raise the engine speed, a greater volume of air-fuel mixture is required than for idling. The carburetor is equipped with the main system for this purpose. The degree of opening of the throttle valve is divided into two stages.

With a degree of opening $1/8 - 1/2$: the air flow in the main bore facilitates a drawing up of the fuel from the gap between the jet needle and needle jet (see Carburetor Theory). The fuel is atomized by air which has entered the air bleed hole of the needle jet holder from the main air jet.

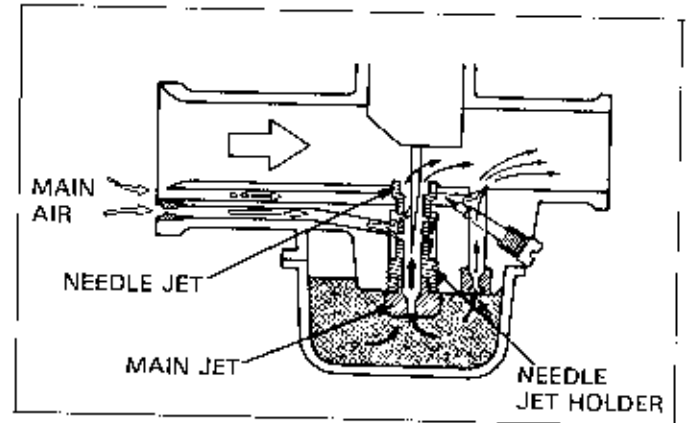

With a degree of opening $1/4 - 3/4$: the fuel drawn from the tapered section of the jet needle is regulated. The greater the valve opening, the further the tapered jet needle rises, increasing the cross sectional area for fuel passage and thus the volume of fuel supplied. In piston type throttle valves, the jet needle contains clip grooves in five stages (Stage 1, 2, 3, etc. counted from the top). The clip position stage number increases, with an increase in the degree of throttle opening, raising the cross sectional area of fuel passage, and hence the volume of fuel.

Size of the main jet does not affect the air-fuel mixture ratio at this stage, as the fuel flow at main jet is greater than at the needle jet.

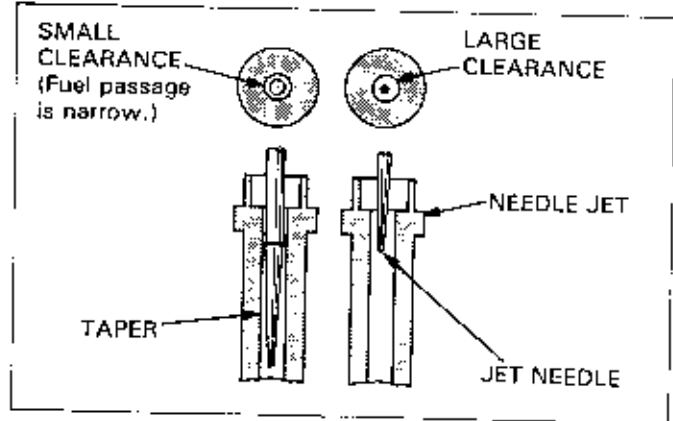

Main system (fully open)

With a degree of throttle opening of $1/2 -$ fully open, the venturi bore diameter and mass flow of air become maximum. At this time the volume of fuel drawn from the gap between the needle jet and jet needle becomes too great and exceeds the flow volume of the main jet.

When the clearance between the needle jet and jet needle is too great, the fuel flow is regulated by the main jet to prevent an overly rich fuel-air mixture.

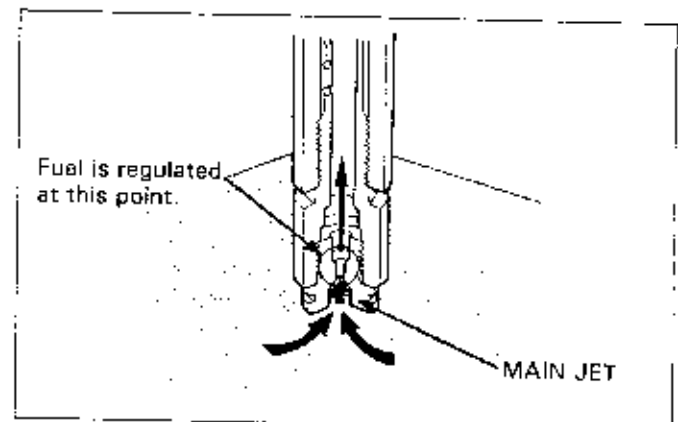

ACCELERATOR PUMP

When the throttle valve is opened suddenly, air-fuel mixture drawn into the cylinder momentarily becomes lean. Because the vacuum at the venturi drops, air flow at the venturi slows down and the drawn-up fuel becomes too little compared with the air. To avoid thinning of the mixture under these conditions, an accelerator pump is used for temporary enrichment. The principle of operation of the pump is as follows.

As the throttle valve is opened, the pump's diaphragm is depressed by the pump rod. At this time the inlet check valve is shut, so the pump chamber undergoes a rise in pressure. The outlet check valve is then opened and fuel is supplied to the main bore via the pump hole.

As the throttle valve is shut down, the accelerator pump's diaphragm is returned by spring action. At this time the inlet check valve is opened and fuel from the float chamber enters the pump chamber. The outlet check valve is closed at this point to prevent air being drawn in through the pump hole.

- Throttle valve opens:

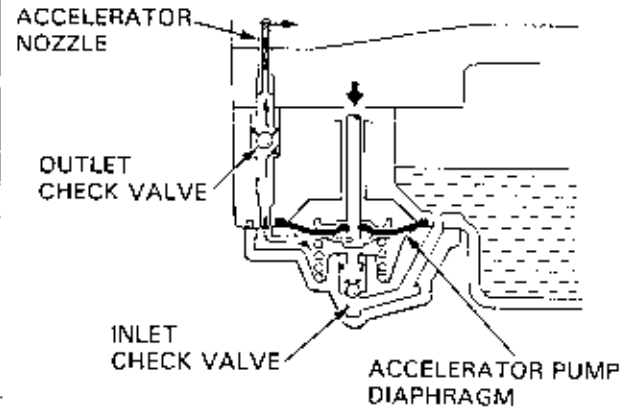

- Throttle valve closes:

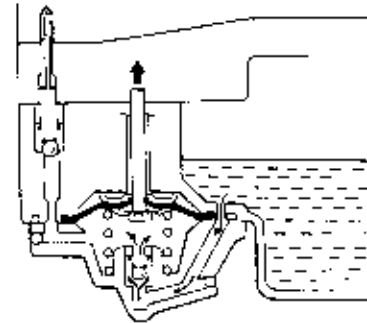

AIR CUT-OFF VALVE

When the throttle lever is turned in the "close" direction and engine braking is applied, the fuel mixture becomes lean. An ignited air/fuel mixture is discharged into the exhaust pipe, resulting the afterburn. To prevent this afterburn, the air cut-off valve shuts the air passage to the slow jet to temporarily make the fuel mixture rich.

With the throttle valve closed and the vacuum in the main bore increased, vacuum in the air cut-off valve also increases and moves the diaphragm to shut the air passage.

With the vacuum in the main bore decreased, the spring moves the diaphragm backward and opens the air passage.

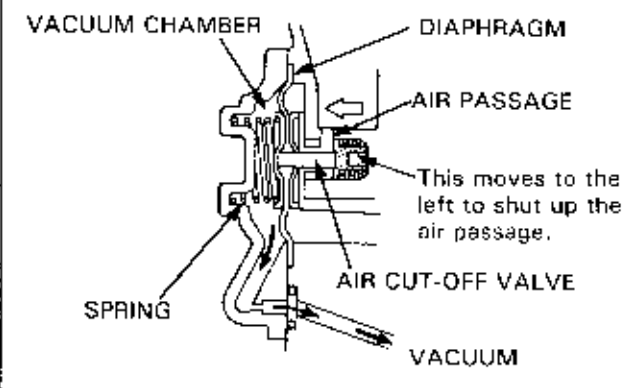

REED VALVE

INSPECTION

Refer to the Model Specific manual for removal/installation.

Check the reed valve for fatigue or damage and replace the reed valve assembly if necessary.

Check the reed valve seat for cracks, damage and clearance from the reed and replace the reed valve assembly if necessary.

NOTE

- Be sure to replace the reed valve as an assembly. Disassembling or bending the reed stopper will cause engine trouble.

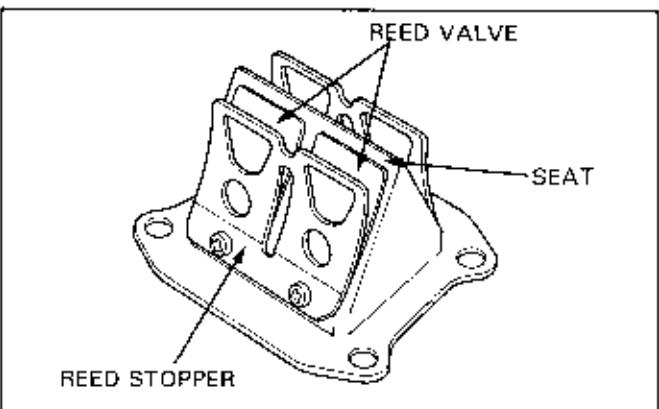

FUEL SYSTEM

FUEL LINE

NOTE

- Refer to section 2 for fuel filter inspection.

1. Check the fuel tank cap and/or fuel tank breather tube for clogging (no breather tube on California, on-road models).
2. Visually inspect the fuel strainer for contamination. Check the fuel flow with the fuel strainer installed and with the strainer removed. Replace the fuel strainer if it is excessively contaminated or if the fuel flow is not smooth.

NOTE

- Note the installation direction of the fuel strainer. Be sure to install it as shown in the drawing, i.e., with the cup facing down. Fuel flows even though the strainer is installed upside down, but it contaminates the inner wall of the strainer and prevents visual inspection of the strainer.

3. Remove the fuel valve lock nut and check the fuel strainer screen for contamination. Tighten the lock nut to the specified torque.

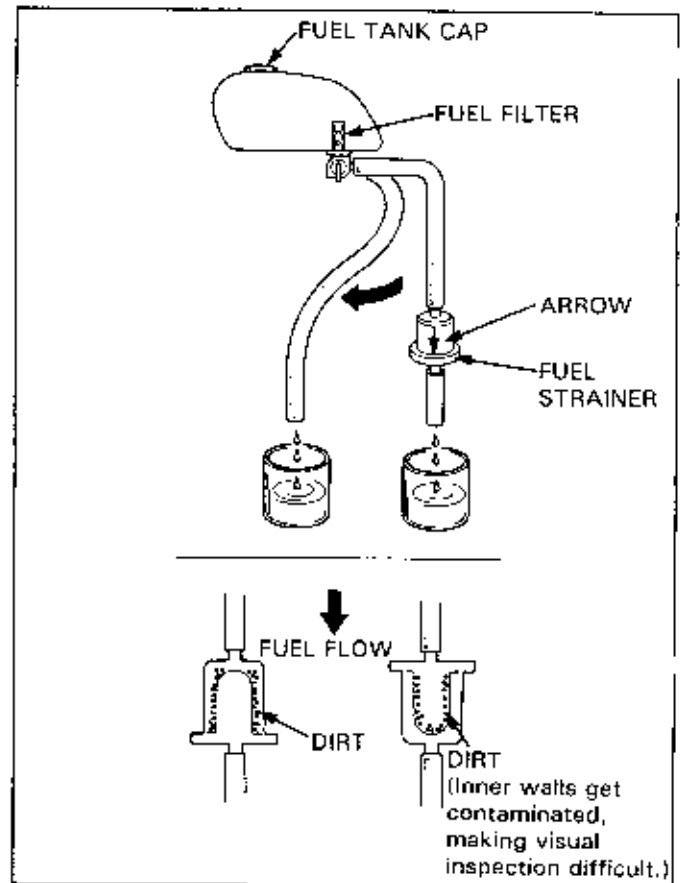

FUEL AUTO VALVE

The fuel auto valve has two diaphragms which are interconnected with an aluminum link.

When the engine is started, vacuum force is applied to the smaller diaphragm through the larger diaphragm and link, the fuel line opens and the fuel starts to flow.

When the engine is stopped, the diaphragms are returned to their original positions by the spring and the fuel line is blocked by the small diaphragm.

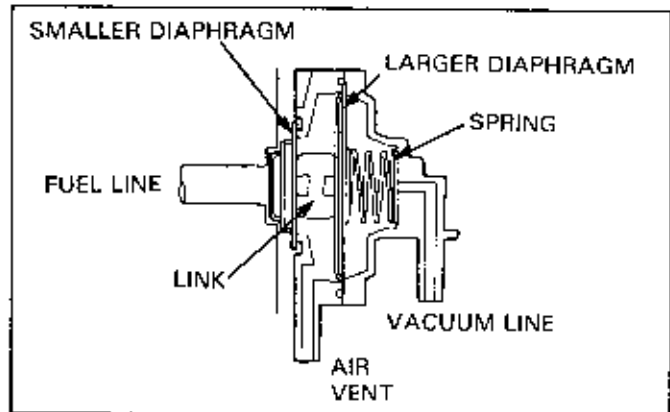

INSPECTION

⚠ WARNING

- Gasoline is extremely flammable and is explosive under certain conditions.

Keep flames and sparks away from gasoline and wipe up spilled gasoline at once.

CAUTION

- Be sure to remove the diaphragms from the fuel auto valve before using compressed air to blow out the air passages. Compressed air will damage the diaphragms or may force them off the aluminum link.

1. Disconnect the fuel line and place it in a clean container as shown.

NOTE

- Place a clean container under the fuel tube.
- Refer to the Model Specific manual for replacement.

2. Connect the fuel auto valve vacuum tube to the vacuum pump and apply vacuum. Be sure that the fuel flows out smoothly.
If the vacuum does not remain steady, it indicates the diaphragm is incorrectly installed or damaged.
If the vacuum remains steady, but the fuel flow is not smooth, it indicates a clogged filter or incorrectly installed diaphragm.
3. If the fuel flows without the vacuum applied, the diaphragm is incorrectly installed.

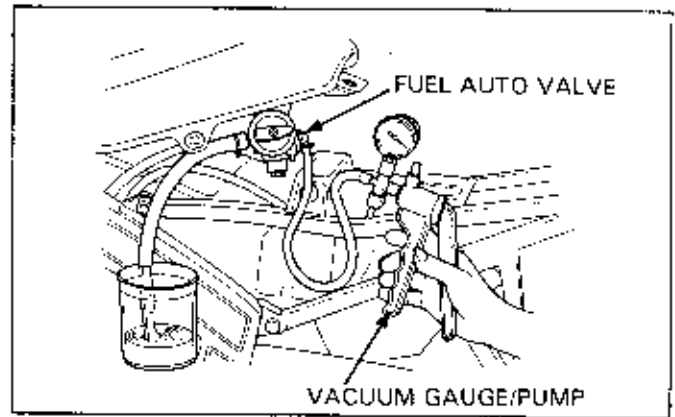

Refer to the Model Specific manual for replacement procedure.

CARBURETOR DISASSEMBLY/INSPECTION

NOTE

- Refer to the Model Specific manual for carburetor removal and disassembly/separation.

THROTTLE VALVE/BYSTARTER VALVE INSPECTON

Move each valve and be sure that it operates smoothly.

Check the throttle valve shaft for play.

Push the relief valve, if it is installed on the throttle valve, and be sure that it opens and closes smoothly.

THROTTLE VALVE INSPECTION (CV type)

Rotate the throttle drum and be sure that it operates smoothly.

Check the throttle valve shaft for play.

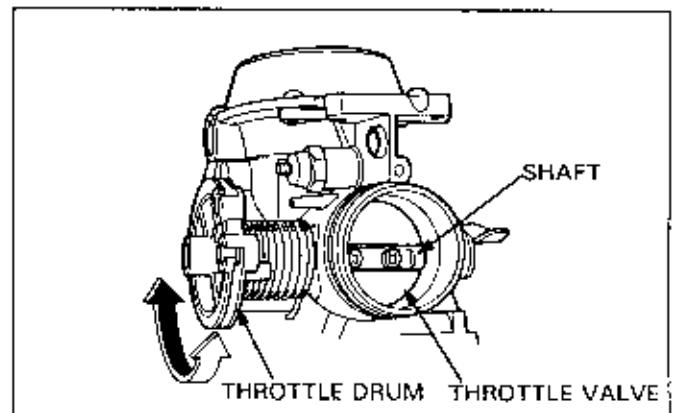
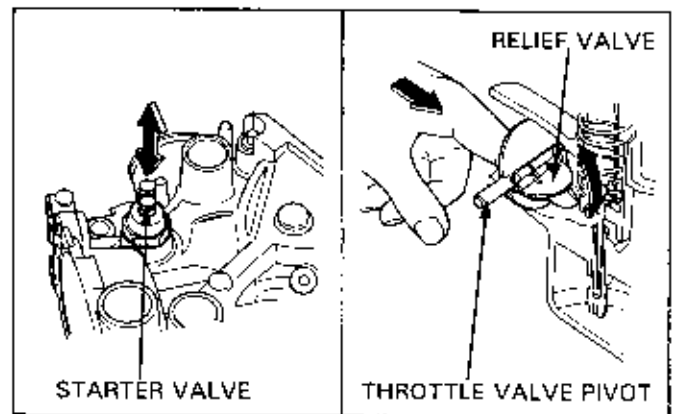

AUTO BYSTARTER VALVE

Connect an ohmmeter to the auto bystarter wire connector terminals and measure the resistance. If the resistance is greatly out of specification, it indicates a faulty PTC in the auto bystarter. Replace the auto bystarter.

NOTE

- The auto bystarter might be normal if the resistance is only slightly out of specification. However, be sure to check all related parts for trouble.
- Refer to the Model Specific manual for specified resistance.

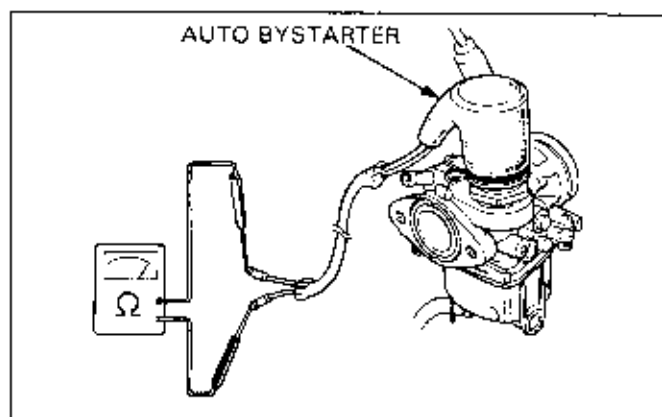

Remove the carburetor and let it cool down for 30 minutes. Insert a vinyl tube into the fuel enriching circuit and blow into the tube.

Air should flow into the circuit.

If air does not flow into the circuit, replace the auto bystarter.

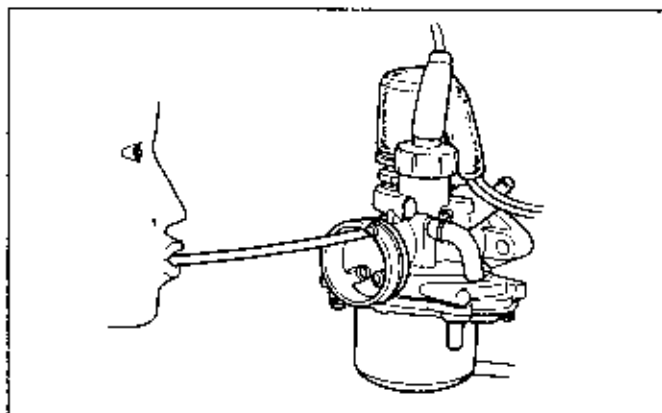

Connect the battery to the auto bystarter terminals and wait for 5 minutes.

Insert a vinyl tube into the fuel enriching circuit and blow into the tube.

Air should not flow into the circuit.

If air flows into the circuit, replace the auto bystarter.

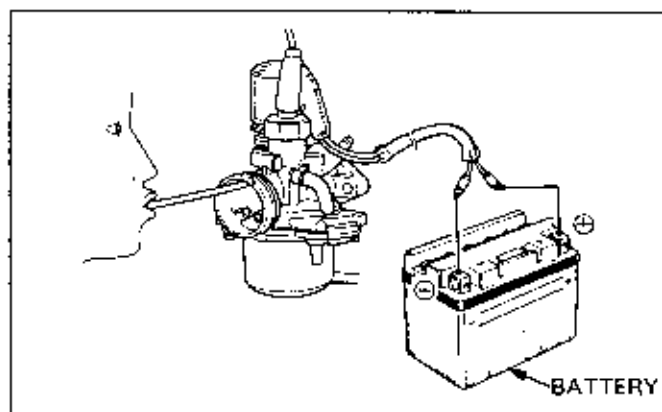

Check the resistor if the auto bystarter is normal but engine is still hard to start.

If there is a broken wire in the resistor, current will not flow to the PTC and the auto bystarter will not operate.

If there is a shorted wire in the resistor, current of a higher voltage than specified will reach the PTC. This will cause the fuel enriching circuit to close too soon, and starting will be difficult.

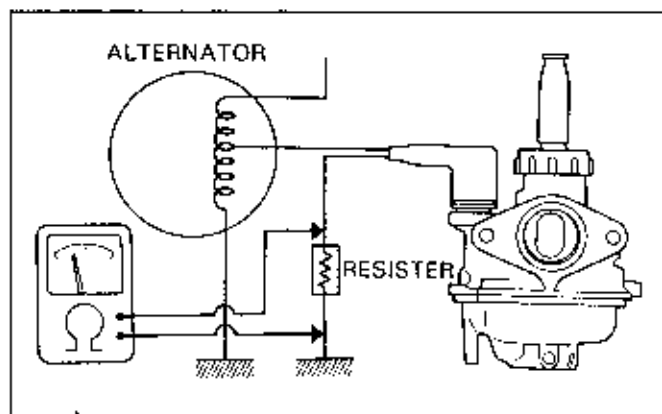

AUTO BYSTARTER REMOVAL

- Remove the bystarter cover.
- Remove the screws and set plate.
- Remove the auto bystarter from the carburetor body.

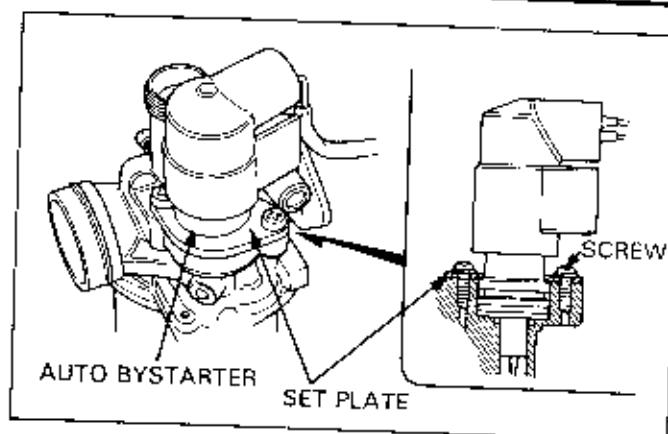

BYSTARTER VALVE (Manual)

- Loosen the starter valve nut and remove the valve spring and valve.
- Check the valve face for scores, scratches or wear and replace if necessary.
- Check the seat at the tip of the valve for stepped wear and replace if necessary.
- If the valve seat is worn or damaged, it will not close the fuel line of the bystarter circuit, resulting in a constantly rich fuel mixture.

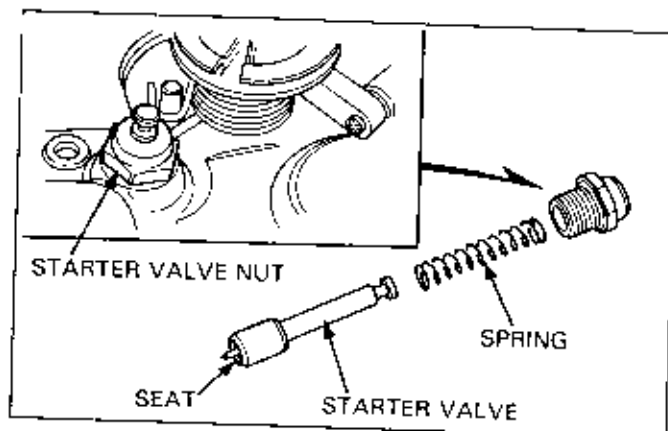

THROTTLE VALVE (Piston valve type)

CAUTION

- Some carburetor/cables have a one-piece throttle cable/carburetor top assembly. Do not try to remove the throttle cable from the carburetor top.

Remove the carburetor top and pull the throttle valve out of the carburetor.

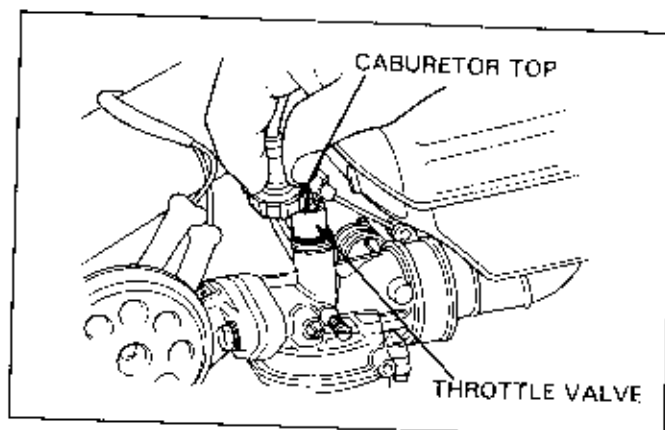

While compressing the spring, disconnect the throttle cable from the throttle valve.

NOTE

- If the throttle valve is linked to the cable, refer to the Model Specific manual for each model for removal/disassembly steps.

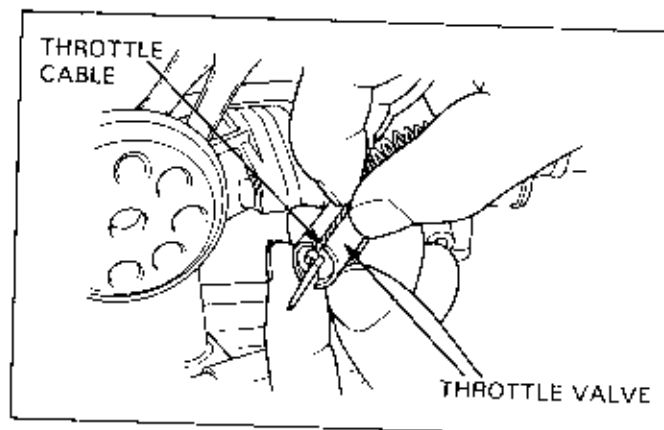

FUEL SYSTEM

Remove the jet needle retainer and jet needle from the throttle valve.

Check the jet needle for stepped wear. The fuel supply to the main circuit cannot be adjusted if the jet needle is worn.

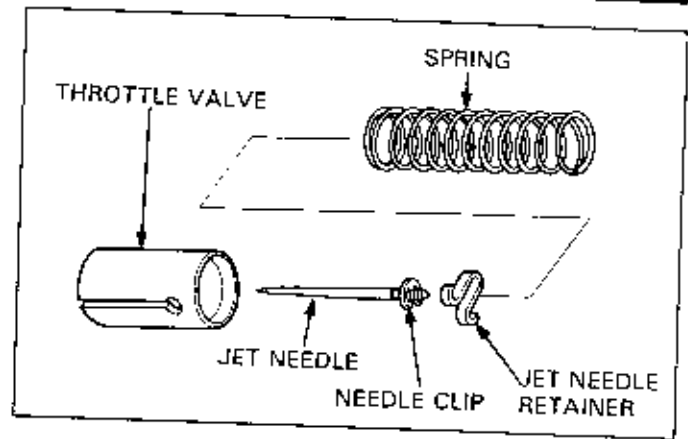

VACUUM PISTON (CV type)

Remove the screws, vacuum chamber cover, spring, and vacuum piston assembly from the carburetor.

Check the piston for smooth operation in the carburetor body.

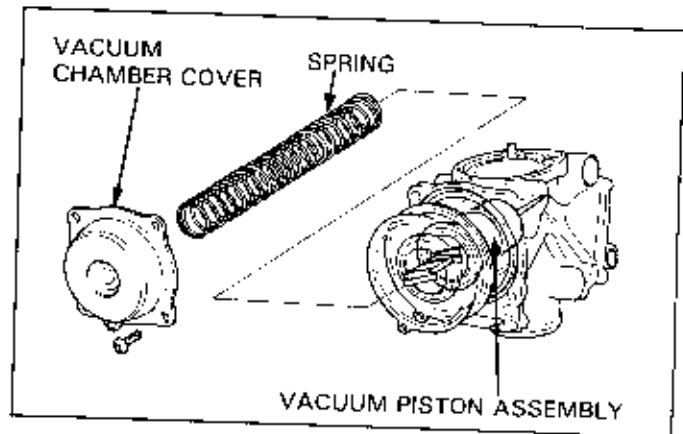

Turn the jet needle holder counterclockwise while prassing it in and remove it.

Remove the spring, spring holder, jet needle, needle holder and washer from the vacuum piston.

NOTE

Certain models are not equipped with a spring holder.

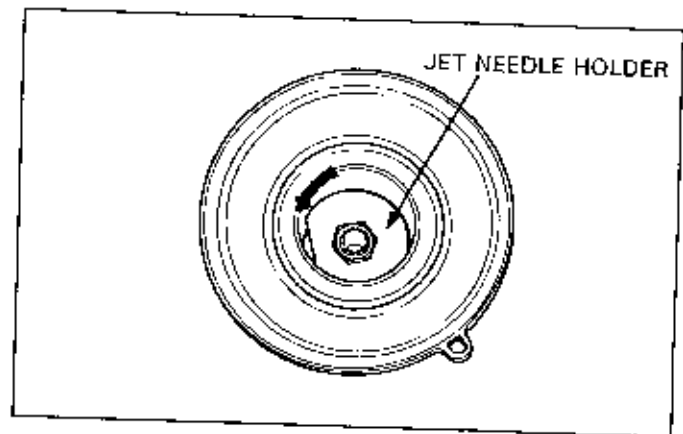

Check the jet needle for stepped wear and replace if necessary.

Check the vacuum piston for damage and replace if necessary.

Check the diaphragm for damage, pin holes, wrinkles and bends and replace if necessary.

Air leaks out of the vacuum chamber if the diaphragm is damaged in any way -- even a pin hole.

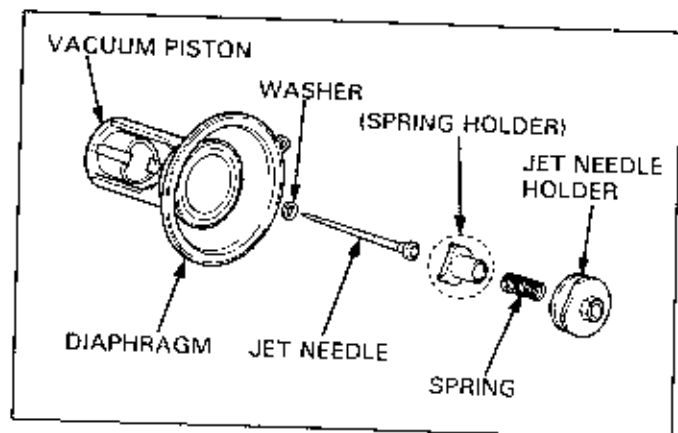

FLOAT/JETS

Remove the float chamber.

Remove the float pin, float and float valve.

Check the float for damage. If it is a hollow float type, also check it for deformation and fuel in the float.

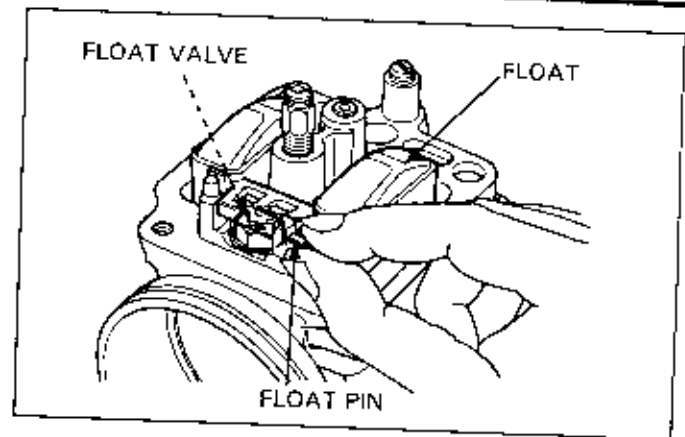

Check the float valve and valve seat for scores, scratches, clogging and damage. Replace if necessary.

Check the tip of the float valve, where it contacts the valve seat, for stepped wear or contamination. Replace the float valve if its tip is worn or contaminated. A worn or contaminated valve does not seat properly and will eventually flood the carburetor.

Remove the valve seat, if it can be removed. (Refer to the Model Specific manual.)

Replace the sealing washer.

Check the filter for damage or clogging. Blow the filter with low pressure air and clean it.

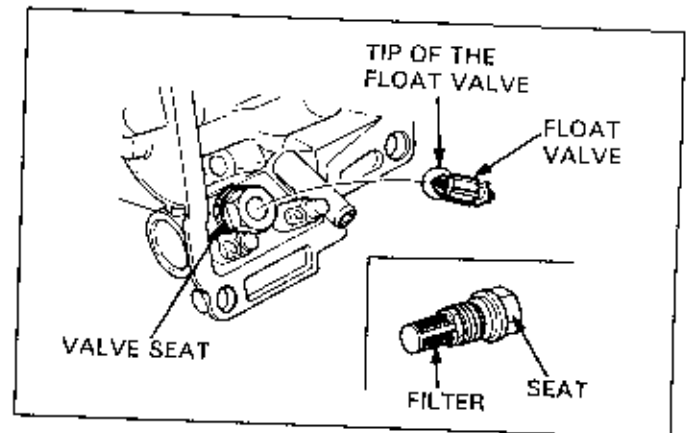

Remove the main jet, needle jet holder, needle jet and slow jet.

NOTE

- Not all carburetors have a removable needle jet and slow jet. (Refer to the Model Specific manual.)

Turn in the pilot (or air) screw and record the number of turns it takes before it seats lightly.

NOTE

- Do not force the screw against its seat; the seat will be damaged.
- Motorcycles with emission control system: Refer to page 8-18 for pilot (or air) screw removal.

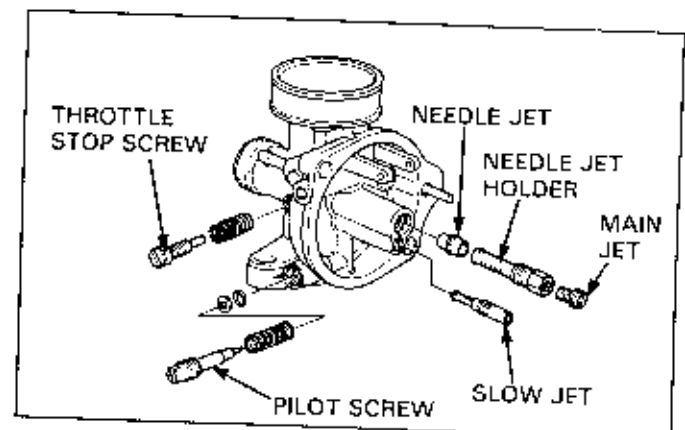

Clean the jets with cleaning solvent and, if necessary, blow open with compressed air.

If the motorcycle is equipped with an accelerator pump, blow open the fuel passages in the float chamber with low pressure air.

FUEL SYSTEM

ACCELERATOR PUMP

Remove the screws and diaphragm cover.

Remove the spring and diaphragm.

Check the rod for bends or damage.

Check the diaphragm for damage or pin holes.

Damage to the rod and/or diaphragm reduces the efficiency of the pump, leading to "hunting" during acceleration.

Blow open the fuel passages in the diaphragm cover with low pressure air.

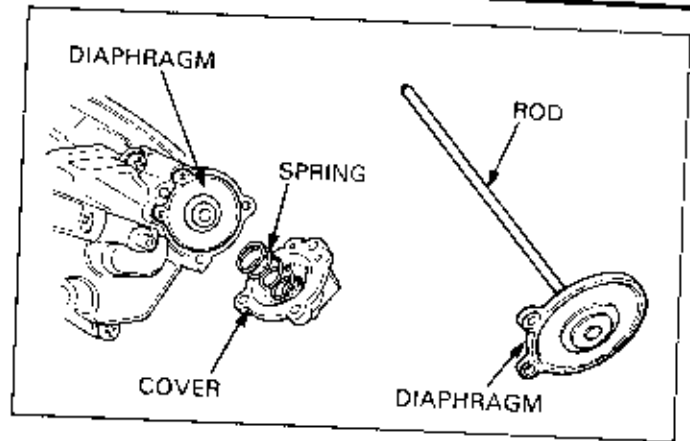

AIR CUT-OFF VALVE

Remove the screws, air cut-off valve cover, spring, diaphragm and O-ring.

Check the diaphragm for damage or pin holes.

Check the O-ring for damage or fatigue.

A worn O-ring and/or damaged diaphragm causes air to leak from the air cut-off valve vacuum chamber.

Blow open air passages in the cover with compressed air.

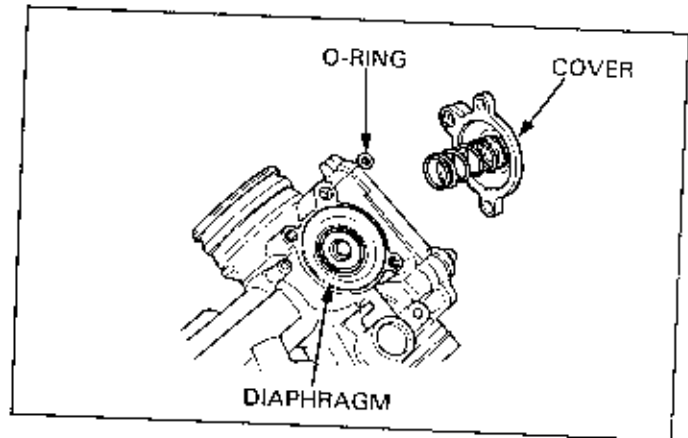

CARBURETOR CLEANING

After removing all parts, blow open air and fuel passages in the carburetor body with compressed air.

CAUTION

- Cleaning the air and fuel passages with a piece of wire will damage the carburetor body or fuel pump.
- Remove the diaphragms to prevent damage to them before using air to blow open the passages.

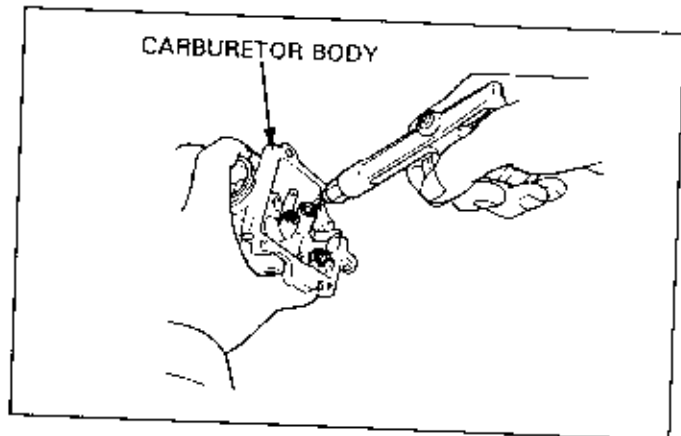

CARBURETOR ASSEMBLY

AIR CUT-OFF VALVE

Install the diaphragm on the carburetor body.

Install the O-ring with its flat side pointed downward.

Install the spring on the cover and install the cover on the carburetor body. Be sure that the diaphragm and O-ring do not interfere with the cover.

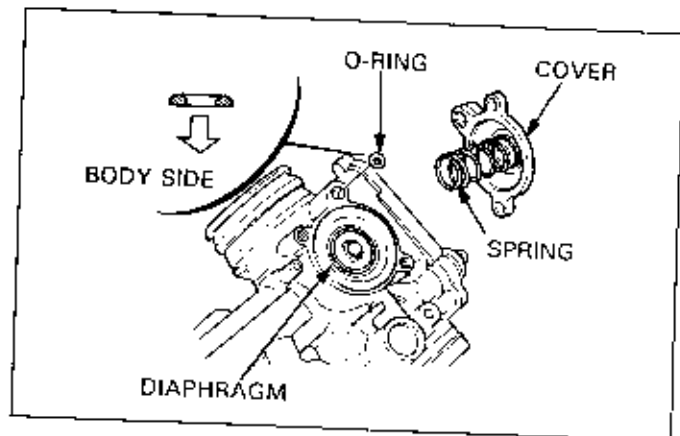

ACCELERATOR PUMP

Align the projections on the diaphragm with the grooves in the float chamber.

Install the spring on the diaphragm cover and install the cover on the float chamber being careful not to pinch the diaphragm.

Adjust the accelerator pump (page 8-24).

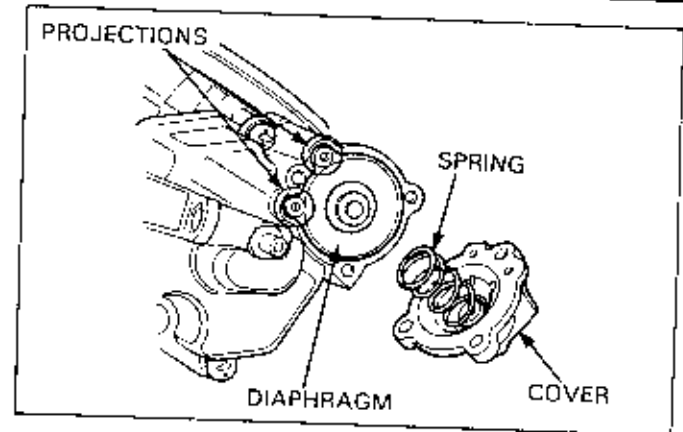

FLOAT/JETS ASSEMBLY

Install the needle jet, needle jet holder, main jet, slow jet, throttle stop screw and pilot (or air) screw on the carburetor body.

Tighten the pilot (or air) screw until it seats lightly, then turn it out as much as the number recorded during removal.

CAUTION

- Tightening the pilot (or air) screw against its seat will damage the seat.

NOTE

- Be sure to install the needle jet with the smaller hole toward the float chamber.
- Install the pilot (or air) screw and its O-ring and washer in the order as shown in the drawing. If the pilot (or air) screw and carburetor body are replaced with the new ones, adjustment is necessary.
- Motorcycles with emission control systems: Refer to page 8-20 for the pilot (or air) screw installation (U.S.A. only).

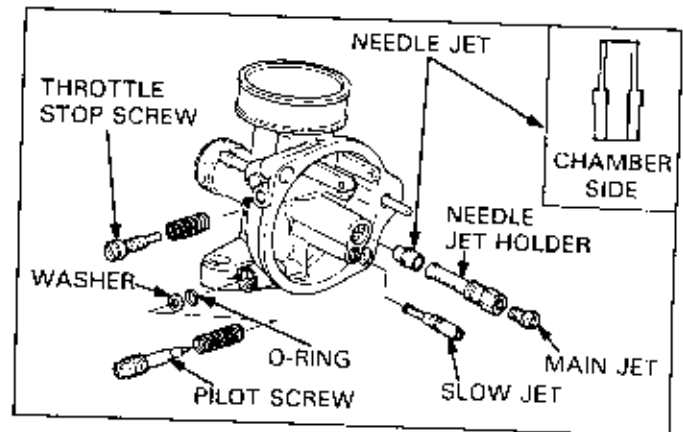

Install the float, float valve and float pin.

Install the O-ring on the float chamber and tighten the float chamber with the screws.

NOTE

- If the float valve must be hung from the float arm lip, note the installation direction of the float valve.

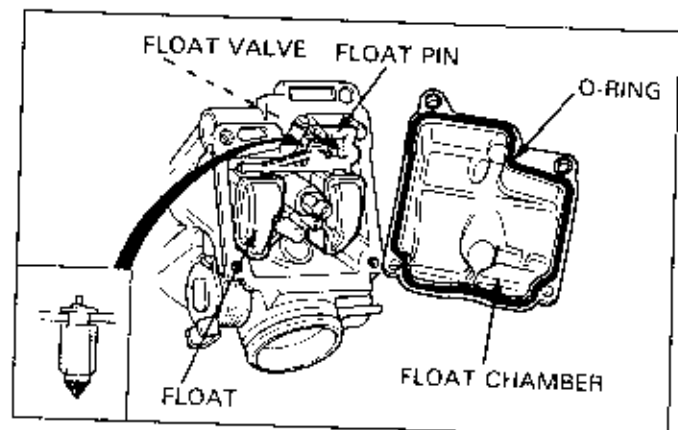

FUEL SYSTEM

FLOAT LEVEL INSPECTION

NOTE

- Check the float level after checking the float valve and float (page 8-13).
- Set the float level gauge so that it is perpendicular to the float chamber face and in line with the main jet.

Set the carburetor so that the tip of the float valve just contacts the float arm lip. Be sure that the float valve is securely in contact with the valve seat.

Measure the float level with the float level gauge.

5 TOOL

FLOAT LEVEL GAUGE

07401-0010000

If the level is out of specification and the float arm lip can be bent, adjust the float level by bending the lip. Non-adjustable floats must be replaced.

NOTE

- Be sure to keep the float level at the specified height. If the float level is low/high, fuel mixture becomes lean/rich.

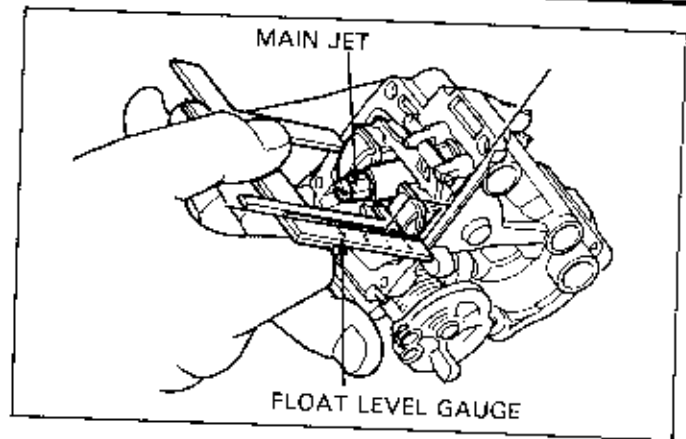

VACUUM PISTON (CV type)

Install the washer on the jet needle and install the jet needle in the vacuum piston.

(Install the spring holder with its pawls aligned with the grooves in the piston, if installed.)

Install the spring.

Turn the jet needle holder clockwise while pressing it into the vacuum piston until it locks. Projections on the vacuum piston and jet needle holder should be aligned after turning.

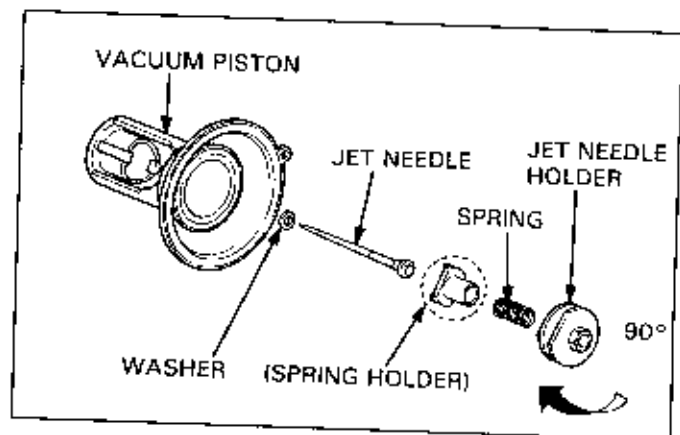

Install the vacuum piston on the carburetor body.

Lift the bottom of the piston with your finger to set the diaphragm rib in the groove in the carburetor body. Install the spring.

Install the vacuum chamber cover with its cutout aligned with the hole in the tab of diaphragm.

NOTE

- Be careful not to pinch the diaphragm, and to keep the spring straight.

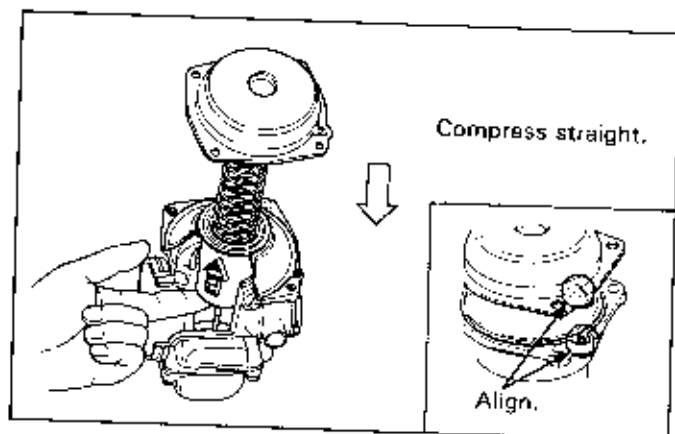

THROTTLE VALVE (Piston valve type)

NOTE

- Cable-operated throttle valve type carburetor (throttle valve is connected to the cable via the link): Refer to the Model Specific manual for throttle valve removal/disassembly.

Install the clip on the jet needle. (Refer to the Model Specific manual for the standard clip position.)

Install the jet needle into the throttle valve and secure with the retainer.

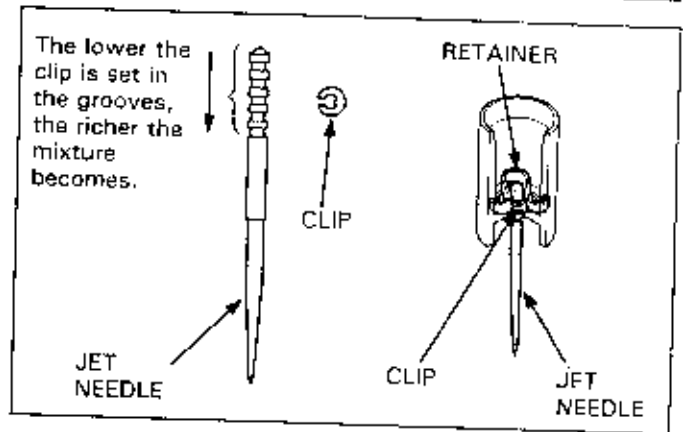

Route the throttle cable through the spring and compress the spring fully.

Attach the throttle cable end to the bottom of the throttle valve and thread the throttle cable through the slot in the valve.

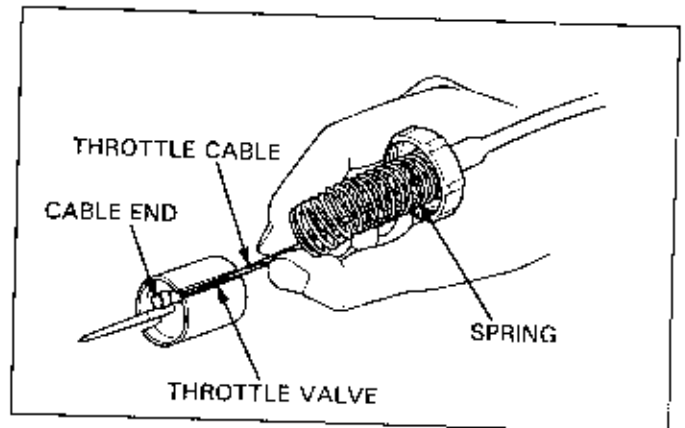

Align the cutout in the throttle valve with the throttle stop screw on the carburetor body and install the valve on the carburetor.

NOTE

- Be sure that the throttle valve cutaway is toward the air cleaner case side as it determines the volume of air for fuel mixture.

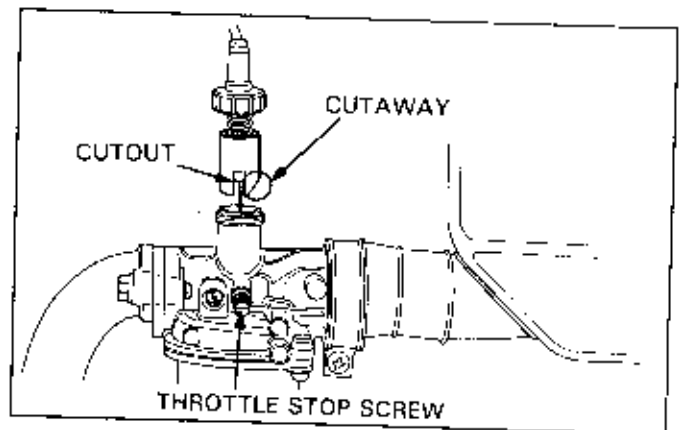

BYSTARTER VALVE (MANUAL)

Install the starter valve, spring and nut.

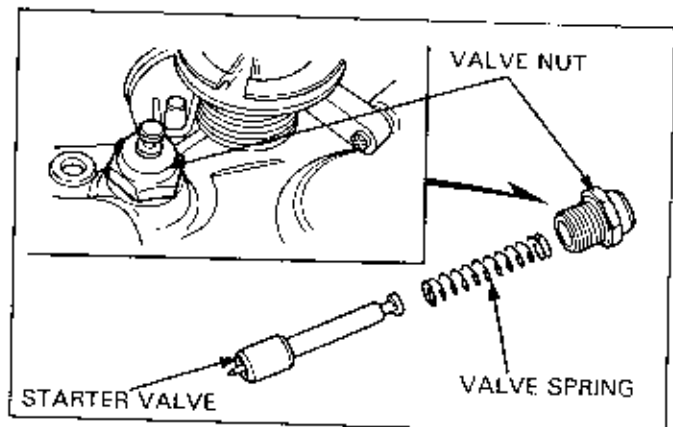

FUEL SYSTEM

AUTO BYSTARTER

Apply a small amount of grease to the O-ring and install the auto bystarter into the carburetor body. Refer to the Model Specific manual for the auto bystarter installation angle.

Secure the auto bystarter with the set plate and screws. Install the auto bystarter cover.

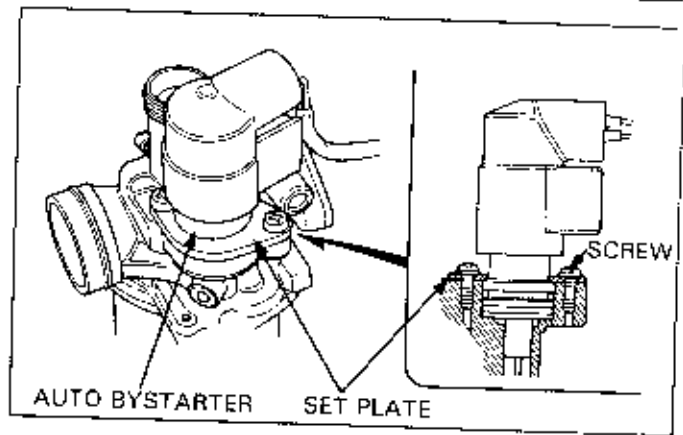

CARBURETOR SEPARATION/ASSEMBLY/ INSTALLATION

Refer to the Model Specific manual for carburetor separation/assembly.

Check and adjust the carburetors as described below after the assembly.

Move the choke arm by hand and be sure that the starter valve operates smoothly.

Rotate the throttle drum and be sure that all the throttle valves open and close smoothly.

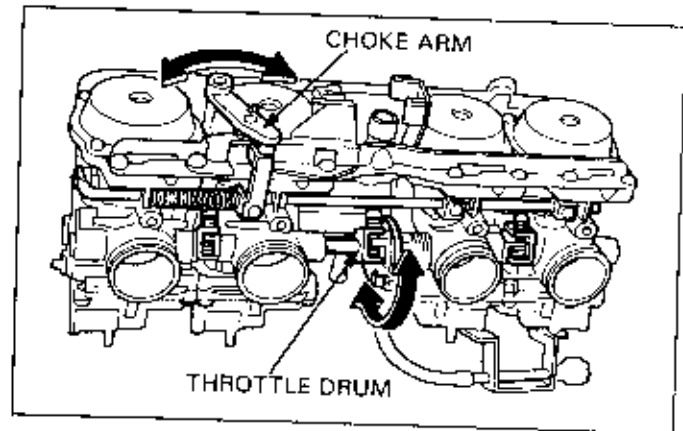

Turn the throttle stop screw to align the throttle valve with the edge of the by-pass hole in the base carburetor. (Base carburetor is the one on which the throttle stop screw is installed. Refer to the Model Specific manual.)

Align each throttle valve with the by-pass hole edge by turning the synchronization adjusting screws. (Refer to the Model Specific manual for the location of each synchronization screw.)

Install the carburetor and adjust the synchronization.

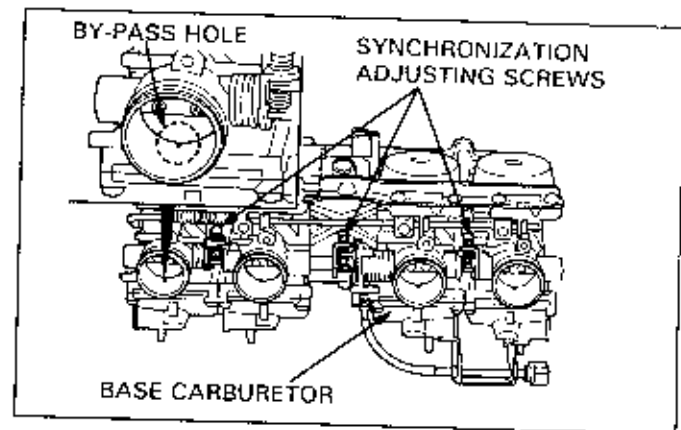

PILOT (OR AIR) SCREW ADJUSTMENT

PILOT (OR AIR) SCREW REMOVAL

NOTE

- Adjust the pilot (or air) screw after all other engine adjustments are within specifications.
- The pilot screw (or air screw) is factory pre-set and should not be removed unless the carburetor is overhauled.
- The screw limiter cap (or plug) is factory installed to prevent misadjustment. Do not remove the limiter cap (or plug) unless the screw is being removed.
- PLUG TYPE ONLY: Cover all openings with tape to keep metal particles out when the plug is drilled.

Limiter cap type

Using a pair of pliers, break off the pilot screw (or air screw) limiter cap and discard it.

Turn the pilot screw (or air screw) in and carefully count the number of turns before it seats lightly.

Make a note of this to use as a reference when reinstalling the pilot screw.

CAUTION

- Tightening the pilot (or air) screw against its seat will damage the seat.

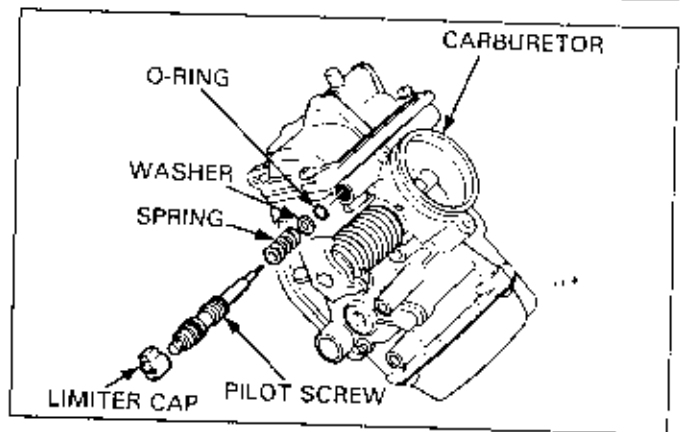

Remove the pilot (or air) screw and inspect it. Replace it if it is worn or damaged.

Plug type

Center punch the pilot screw (or air screw) plug to center the drill point.

Drill through the plug with a 4 mm (5/32 in) drill bit. Attach a drill stop to the bit 3 mm (1/8 in) from the end to prevent drilling into the pilot screw.

CAUTION

- Use extreme care when drilling into the pilot (or air) screw to avoid damaging it.

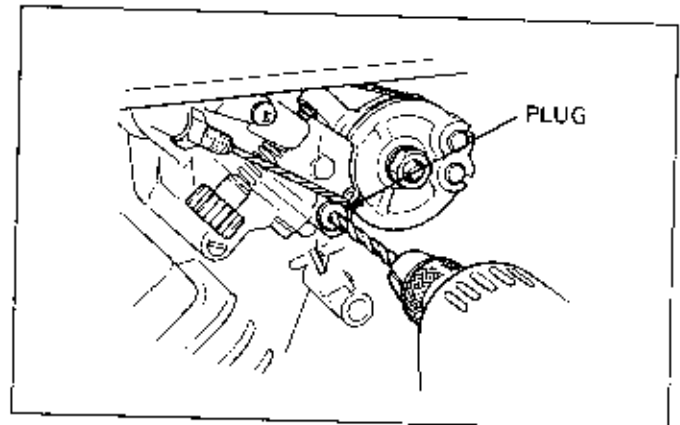

Force a self-tapping 4 mm screw (H/C 069399, P/N 93903-3541) into the drilled plug and continue turning the screwdriver until the plug rotates with the screw.

Pull on the screw head with pliers to remove the plug.

Use compressed air to clean the screw area and remove metal shavings.

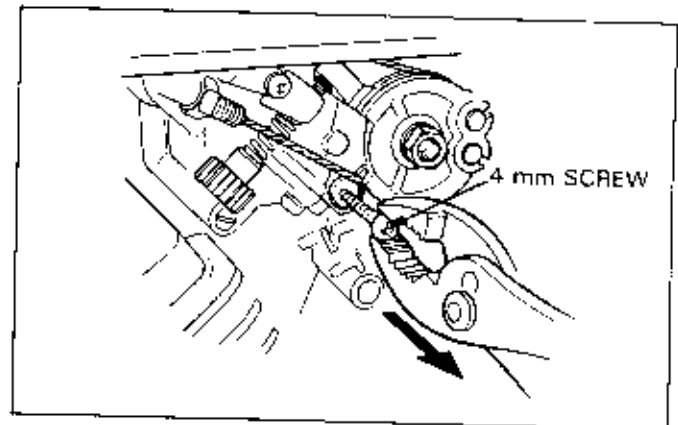

Turn the screw in and carefully count the number of turns until it seats lightly. Make a note of this to use as a reference when reinstalling the screw.

CAUTION

- Tightening the pilot (or air) screw against its seat will damage the seat.

Remove the screw and inspect it. Replace it if it is worn or damaged.

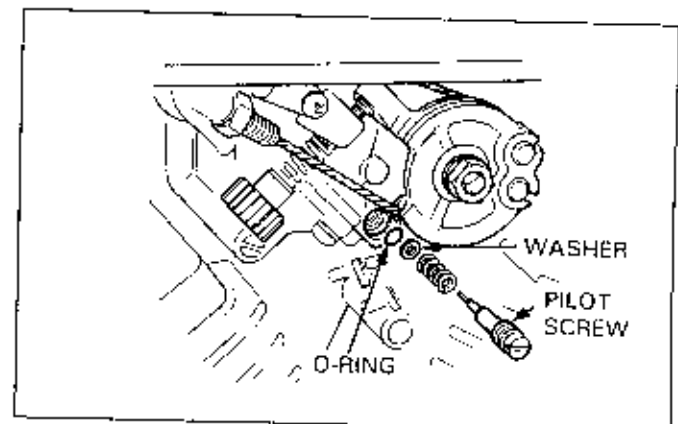

FUEL SYSTEM

PILOT (OR AIR) SCREW INSTALLATION

Install the screw and return it to its original position as noted during removal.

Perform the pilot screw (or air screw) adjustment if a new screw is installed.

NOTE

- If you replace the pilot screw in one carburetor, you must replace the pilot screws in the other carburetors for proper pilot screw adjustment.
- Do not install a limiter cap or plug over a pilot (or air) screw until the screw has been properly adjusted.

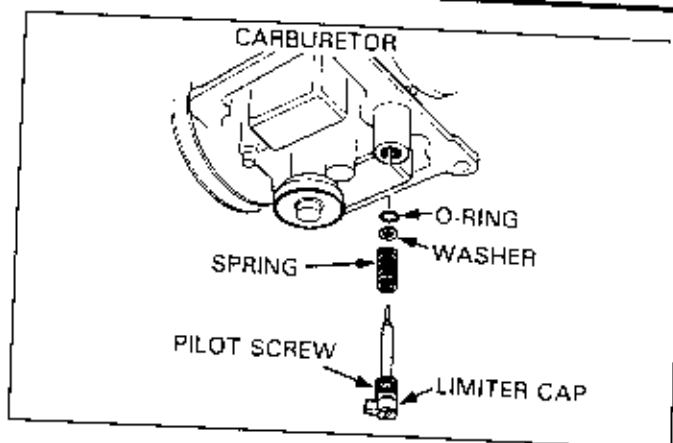

PILOT SCREW ADJUSTMENT

IDLE DROP PROCEDURE (4 stroke, multi-carburetor, emissions control applicable models)

NOTE

- Make sure the carburetor synchronization is within specification before pilot screw adjustment.
- The pilot screws are factory pre-set and no adjustment is necessary unless the pilot screws are replaced.
- Use a tachometer with graduations of 50 rpm or smaller that will accurately indicate a 50 rpm change.

1. Turn each pilot screw clockwise until it seats lightly, then back it out to the specification given. This is an initial setting prior to the final pilot screw adjustment.

INITIAL OPENING: Refer to the Model Specific manual.

CAUTION

- Tightening the pilot screw against its seat will damage the seat.

2. Warm up the engine to operating temperature. Ten minutes of stop and go driving is sufficient.
3. Attach a tachometer according to its manufacturer's instructions.
4. Adjust the idle speed to the specified rpm with the throttle stop screw.

IDLE SPEED: Refer to the Model Specific manual.

5. Turn all pilot screws 1/2 turn out from the initial setting.
6. If the engine speed increases by 50 rpm or more, turn all pilot screws out by successive 1/2 turn increments until engine speed does not increase.
7. Adjust the idle speed with the throttle stop screw.
8. Turn the No. 1 carburetor pilot screw in until the engine speed drops 50 rpm.

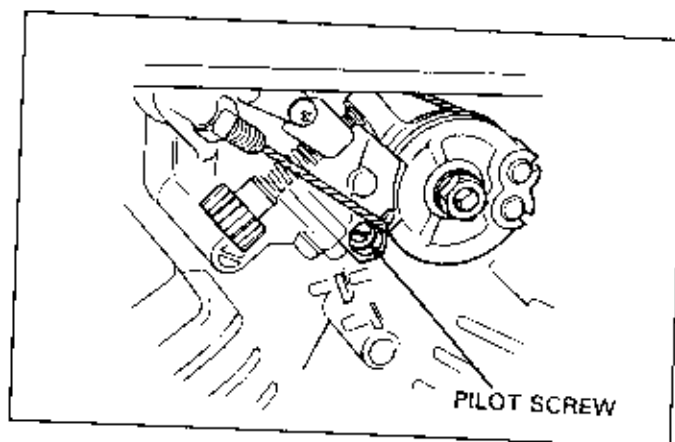

9. Turn the No. 1 carburetor pilot screw counterclockwise to the final opening from the position obtained in step 8.

FINAL OPENING: Refer to the Model Specific manual.

10. Adjust the idle speed with the throttle stop screw.
11. Perform steps 8, 9 and 10 for all the carburetor pilot screws.
12. Install the new limiter cap (or plug) onto the pilot screw head (page 8-23).

IDLE DROP PROCEDURE (4 stroke, single carburetor, emissions control applicable models)

NOTE

- The pilot screw is factory pre-set and no adjustment is necessary unless the pilot screw is replaced.
- Use a tachometer with graduations of 100 rpm or smaller that will accurately indicate a 100 rpm change.

1. Turn pilot screw clockwise until it seats lightly, then back it out to the specification given. This is an initial setting prior to the final pilot screw adjustment.

INITIAL OPENING: Refer to the Model Specific manual.

CAUTION

- Tightening the pilot screw against its seat will damage the seat.

2. Warm up the engine to operating temperature. Ten minutes of stop and go driving is sufficient.
3. Attach a tachometer according to its manufacturer's instructions.
4. Adjust the idle speed with the throttle stop screw.

IDLE SPEED: Refer to the Model Specific manual.

5. Turn the pilot screw in or out slowly to obtain the highest engine speed.
6. Readjust the idle speed with the throttle stop screw.
7. Turn the pilot screw in gradually until the engine speed drops 100 rpm (50 rpm on some models.)
8. Turn the pilot screw counterclockwise to the final opening from the position obtained in step 7.

FINAL OPENING: Refer to the Model Specific manual.

9. Readjust the idle speed with the throttle stop screw.
10. Install the new limiter cap (or plug) onto the pilot screw head (page 8-23).

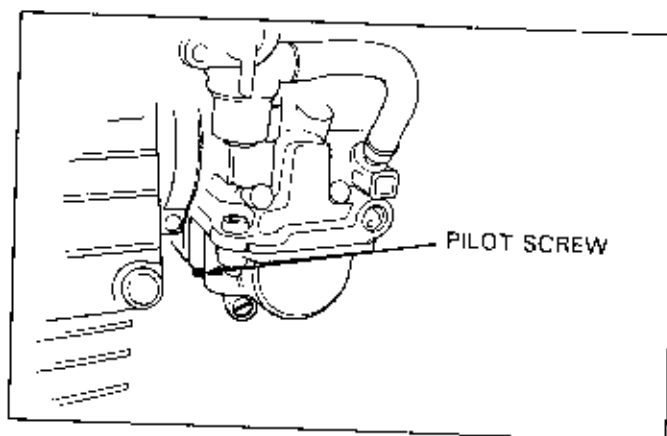

FUEL SYSTEM

AIR SCREW OR PILOT ADJUSTMENT

BEST IDLE PROCEDURE (4 stroke, all models)

NOTE

- The air or pilot screw is factory pre-set. Adjustment is not necessary unless the carburetor is overhauled or a new air or pilot screw is installed.

CAUTION

- Tightening the air or pilot screw against its seat will damage the seat.

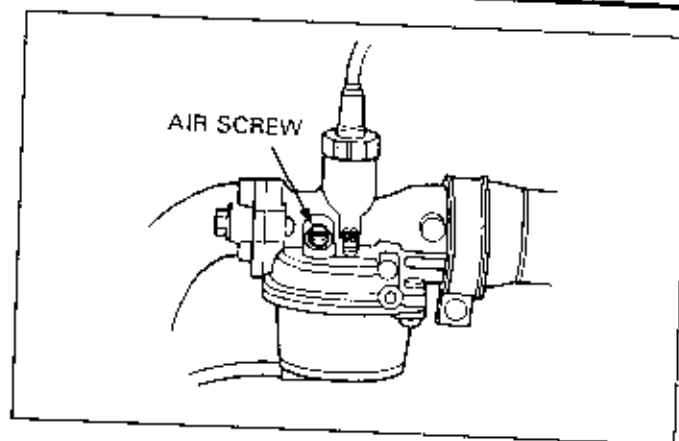

1. Turn the air or pilot screw clockwise until it seats lightly, then back it out to the specification given. This is an initial setting prior to the final air or pilot screw adjustment.

AIR OR PILOT SCREW OPENING: Refer to the Model Specific manual.

2. Warm up the engine to operating temperature. Ten minutes of stop and go driving is sufficient.
3. Stop the engine and connect a tachometer.
4. Start the engine and adjust the idle speed with the throttle stop screw.

IDLE SPEED: Refer to the Model Specific manual.

5. Turn the air or pilot screw in or out slowly to obtain the highest engine speed.
6. Readjust the idle speed to the specified value with the throttle stop screw.
7. Make sure that the engine does not miss or run erratically. Repeat steps 5 and 6 until engine speed increases smoothly.
8. Readjust the idle speed with the throttle stop screw.
9. Install the limiter cap (or plug) on to the air or pilot screw head (if applicable). (page 8-23).

AIR SCREW ADJUSTMENT (2-stroke engine only)

Warm the engine up to operating temperature.

Turn the air screw clockwise until it seats lightly, then back it out to the specification given.

AIR SCREW OPENING: Refer to the Model Specific manual.

CAUTION

- Tightening the air screw against its seat will damage the seat.

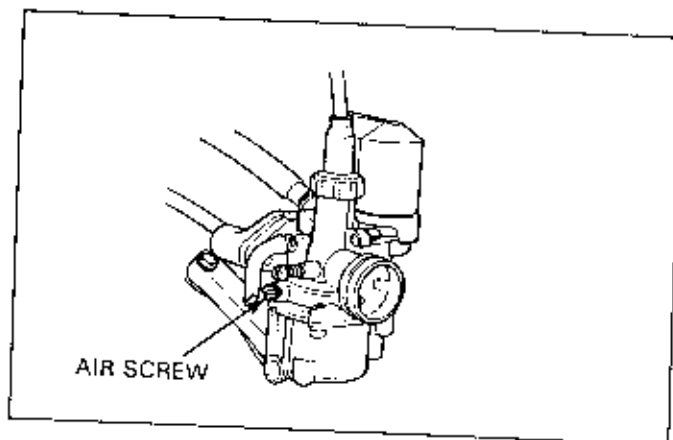

Adjust the idle speed with the throttle stop screw.

IDLE SPEED: Refer to the Model Specific manual.

Rev the engine up slightly from the idle speed and make sure that engine speed rises and returns smoothly.

Adjust by turning the air screw in or out within a 1/4 turn if necessary. If the engine cannot be adjusted by turning the air screw within a 1/4 turn, check for other engine problems.

LIMITER CAP (OR PLUG) INSTALLATION

LIMITER CAP

If the pilot screw (or air screw) is removed, a new limiter cap must be installed after the screw is adjusted.

After adjustment, cement the limiter caps over the screws, using LOCTITE® 601 or equivalent. The limiter cap should be placed against its stop as shown preventing further adjustment that would enrich the fuel mixture.

Pilot screw: the limiter cap position permits clockwise rotation and prevents counterclockwise rotation.

Air screw: the limiter cap position permits counterclockwise rotation and prevents clockwise rotation.

NOTE

- Do not turn the pilot screw (or air screw) when installing the limiter cap.

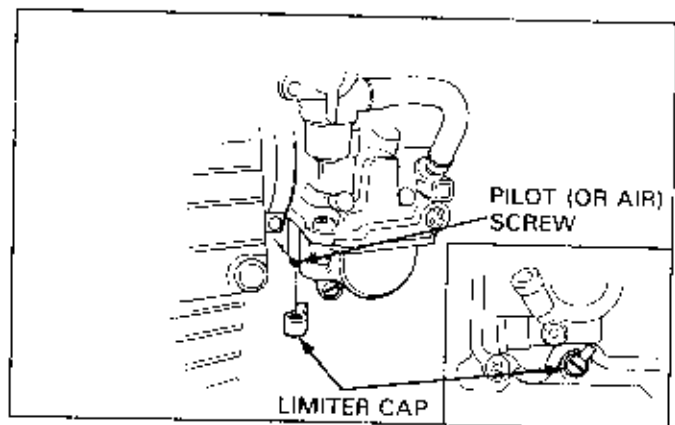

LIMITER PLUG

Drive new pilot screw (or air screw) plug into the pilot screw (or air screw) bore with a 7 mm valve guide driver (P/N 07942-8230000).

When fully seated the plug surface will be recessed 1 mm.

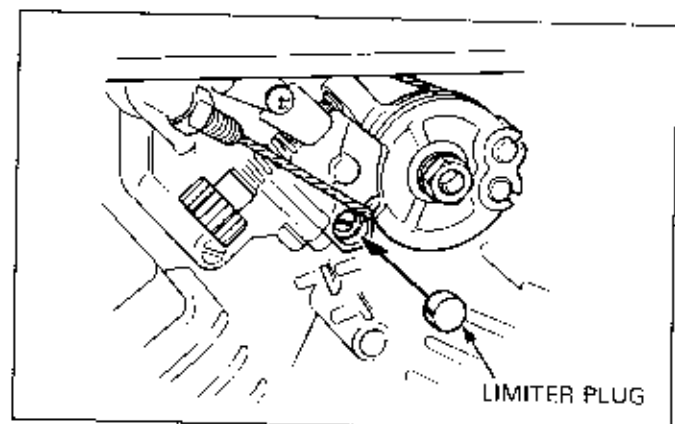

FUEL SYSTEM

ACCELERATOR PUMP ADJUSTMENT

NOTE

- Accelerator pump adjustment is not necessary unless the adjusting screw is replaced.

Adjust the idle speed.

Adjust the throttle grip free play.

Measure the clearance between the accelerator pump rod and pump arm.

CLEARANCE: Refer to the Model Specific manual.

If the clearance is not within specification, adjust the clearance by carefully bending the pump arm or by turning the adjusting screw. (Refer to the Model Specific manual.)

HIGH ALTITUDE ADJUSTMENT (U.S.A. only)

When the vehicle is to be operated continuously above 6,500 feet (2,000 m) the carburetor must be readjusted as follows to improve driveability and decrease exhaust emission.

Warm up the engine to operating temperature. Ten minutes of stop and go driving is sufficient.

Turn the pilot screw clockwise to the specified opening (or turn the air screw counterclockwise to the specified opening.)

Refer to the Model Specific manual for standard and high altitude setting.

NOTE

- This adjustment must be made at high altitude to ensure proper high altitude operation.
- On some models the standard main jet must be replaced with an optional, smaller high altitude jet.

Attach a Vehicle Emission Control Information Update Label in the location specified in the label position illustration. (Refer to the Model Specific manual for the specified position.)

NOTE

- Do not attach the label to any part that can be easily removed from the vehicle.

WARNING

- Operation at an altitude lower than 5,000 feet (1,500 m) with the carburetors adjusted for high altitudes may cause the engine to idle roughly and the engine may stall in traffic.

When the vehicle is to be operated continuously below 5,000 feet (1,500 m), turn the pilot screw counterclockwise (the air screw clockwise) to its original position and reinstall the standard main jet (as necessary), and adjust the idle speed to the specified rpm.

Be sure to make these adjustments at low altitude.

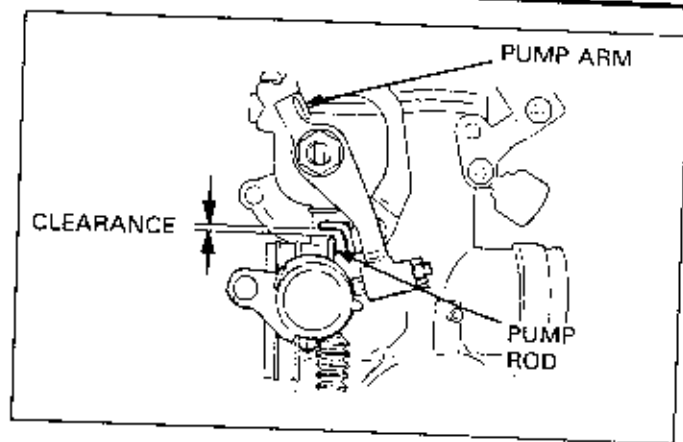

UPDATE LABEL

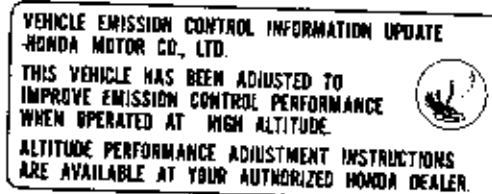

9. CYLINDER HEAD

SERVICE INFORMATION	9-1	VALVE SPRINGS	9-8
TROUBLESHOOTING	9-1	VALVES	9-8
SYSTEM DESCRIPTION	9-2	VALVE GUIDES	9-9
CAMSHAFT	9-5	VALVE SEATS	9-11
ROCKER ARM, ROCKER ARM SHAFT	9-6	CYLINDER HEAD ASSEMBLY	9-14
CYLINDER HEAD INSPECTION	9-7	INITIAL CAMSHAFT LUBRICATION	9-15
CYLINDER HEAD DISASSEMBLY	9-8		

SERVICE INFORMATION

- Refer to Engine Testing, section 3, for cylinder compression and leak-down testing.
- Remove accumulated carbon from the cylinder head of two-stroke engines as described in the Model Specific manual.
- Camshaft lubricating oil is fed through oil passages in the cylinder head. Clean the oil passages before assembling the cylinder head.
- Clean all disassembled parts with cleaning solvent and dry them by blowing them off with compressed air before inspection.
- Before reassembly, lubricate the sliding surfaces of the parts (see each Model Specific manual for lubrication).
- When disassembling, mark and store the disassembled parts to ensure that they are reinstalled in their proper locations.
- Loosen the cylinder head bolts in a crisscross pattern in two or three steps from outside to center and from small diameter to large diameter.
- When tightening cylinder head bolts:
 - tighten the bolts and nuts to the specified torque in the sequence described in Model Specific manual, or if the sequence is not described, tighten according to the following general rule.
 - hand-tighten the bolts and nuts, then torque large bolts and nuts before small ones in a crisscross pattern from inner-to-outer in two or three gradual steps.
- If it is no longer clear which bolt belongs in which hole, insert all bolts in the holes and check the exposed lengths; each should be exposed the same amount.

TROUBLESHOOTING

Engine top-end problems usually affect engine performance. These can be diagnosed by a compression or leak down test, or by tracing noises to the top-end with a sounding rod or stethoscope.

Low compression

- Valves
 - Incorrect valve adjustment (see section 2)
 - Burned or bent valves
 - Incorrect valve timing
 - Broken valve spring
 - Uneven valve seating
- Cylinder head
 - Leaking or damaged head gasket
 - Warped or cracked cylinder head
- Cylinder, piston (see section 10)
- Leaking crankcase primary compression (2-stroke engine)
 - Blown crankcase gasket
 - Damaged crankshaft oil seal

Rough idle

- Low cylinder compression
- Incorrect decompression adjustment

Compression too high

- Excessive carbon build-up on piston or combustion chamber

Excessive noise

- Incorrect valve adjustment
- Sticking valve or broken valve spring
- Damaged or worn camshaft
- Loose or worn cam chain
- Worn or damaged cam chain tensioner
- Worn cam sprocket teeth
- Worn rocker arm and/or shaft

Kick starting difficult

- Incorrect decompressor adjustment
- Seized engine

SYSTEM DESCRIPTION

CONSTRUCTIONS

As cylinder heads are subject to considerable combustion heat and pressure, they are made of a one-piece aluminum casting with considerable strength and cooling capability. Air-cooled engines are provided with air cooling fins, and liquid-cooled engines with a water jacket, respectively, necessary to cool the engine.

The cylinder head encloses a combustion chamber. A hemisphere shape is most common, providing a minimum possible space for improved combustion efficiency. Where four valves per cylinder are used in a 4-stroke engine, the combustion chamber is shaped like a shed roof, according to the valve arrangement. Some models, of both 2 and 4-stroke engines, are provided with squish areas on the outer circumference of the combustion chamber. This has the effect of improving combustion efficiency at the final stage of the compression process by extra compression of the air/fuel mixture in the squish areas between the piston and cylinder head and forcing it to the center of the combustion chamber. There is also the added advantage of decreased carbon adhesion.

The construction of the cylinder head with 2-stroke engines is simple. 4-stroke engines, however, have a complicated configuration containing extra parts, due to the necessity of valve actuating mechanisms and exhaust ports. Furthermore, the intake/exhaust port configuration of a 4-stroke engine has a direct relation to the engine performance. There is therefore a tendency to adopt a layout allowing a very direct inlet for a smoother air/fuel mixture, by aligning the intake port from the carburetor to the combustion chamber.

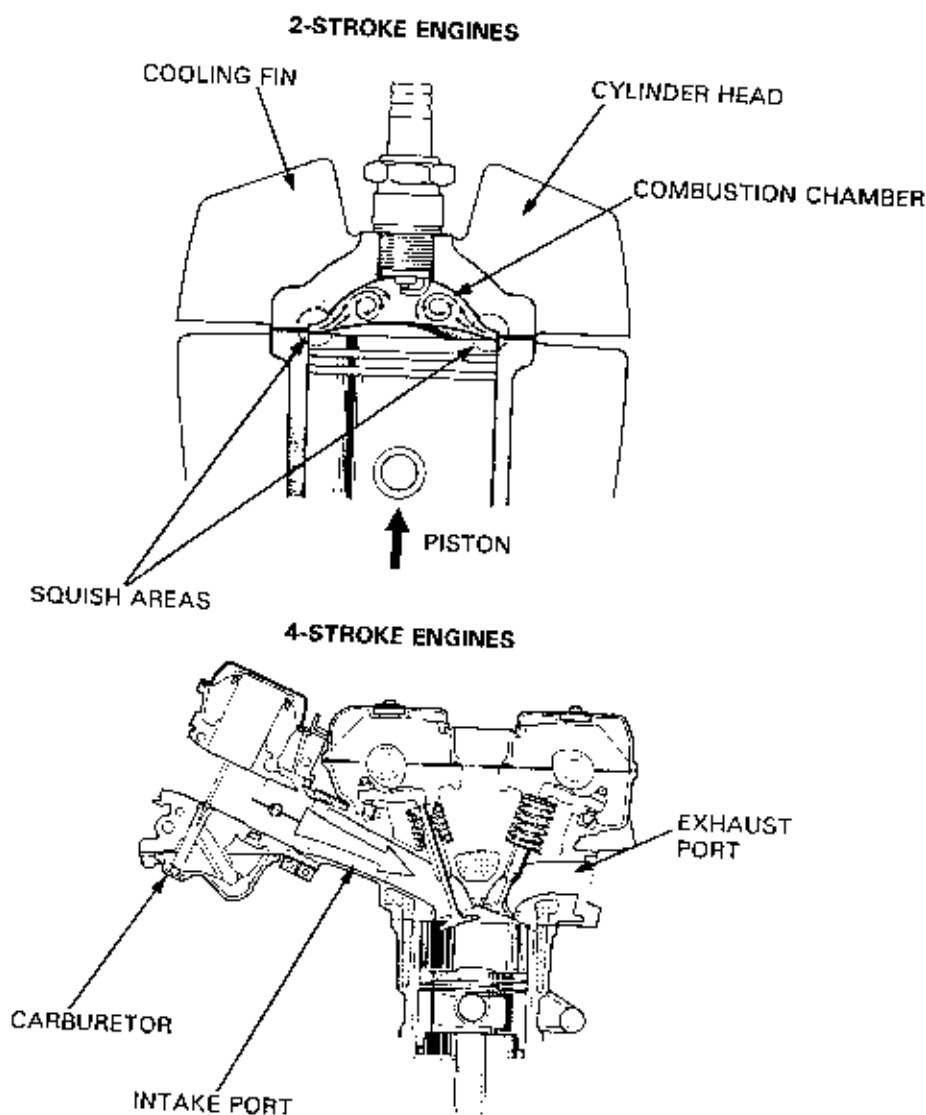

VALVE TRAIN

The current valve train designs used on 4-stroke engines is divided into 3 types: a conventional chain drive, a belt drive (with considerable noise reduction), and a gear drive used in high performance engines. A chain drive is the most commonly used mechanism for current valve train design. Its simple construction allows for lower cost of manufacture. Some maintenance is required, however, because eventually chain elongation increases chain noise. Chain maintenance is not required with types using an "automatic cam chain tensioner". The automatic cam chain tensioner provides spring support by pressing the chain in the direction of tension and locking against any counter-pressure. This provides the automatic elimination of chain slack.

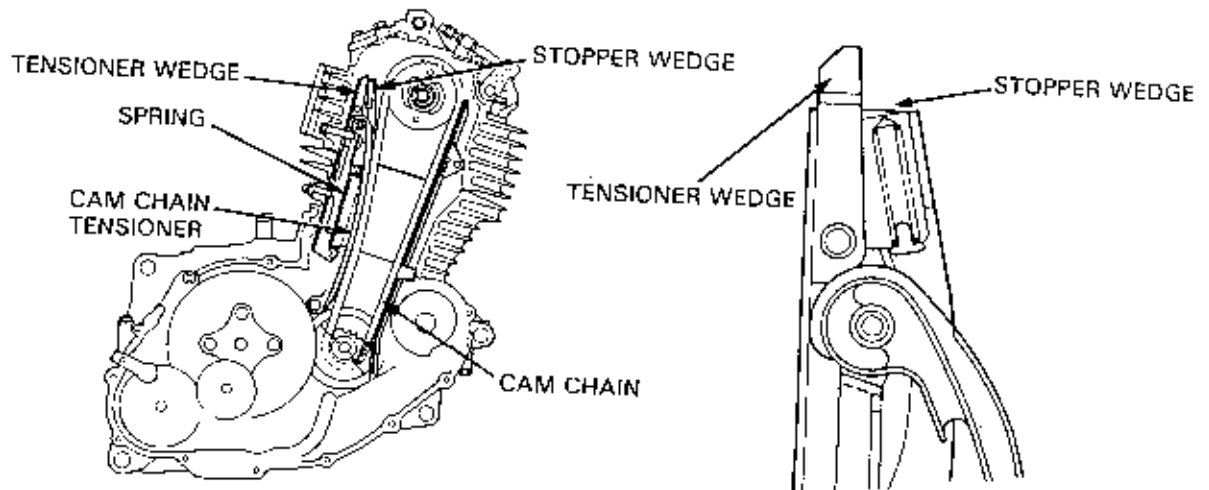

The GOLDWINGS adopt a belt drive system similar to that used on Honda automobiles. This type is used on engines requiring less noise. There are also models adopting valve drive by gear. This type has minimal friction loss from valve drive and maintains accurate valve timing even at high engine speeds. Accordingly, this type is adopted for sport machines. The camshaft drive gear mechanism between the crankshaft and the camshaft is of a cassette type, allowing easier mounting/removal of the camshaft and gear case in comparison to the chain drive. Both types require no maintenance and provide reliable strength and durability.

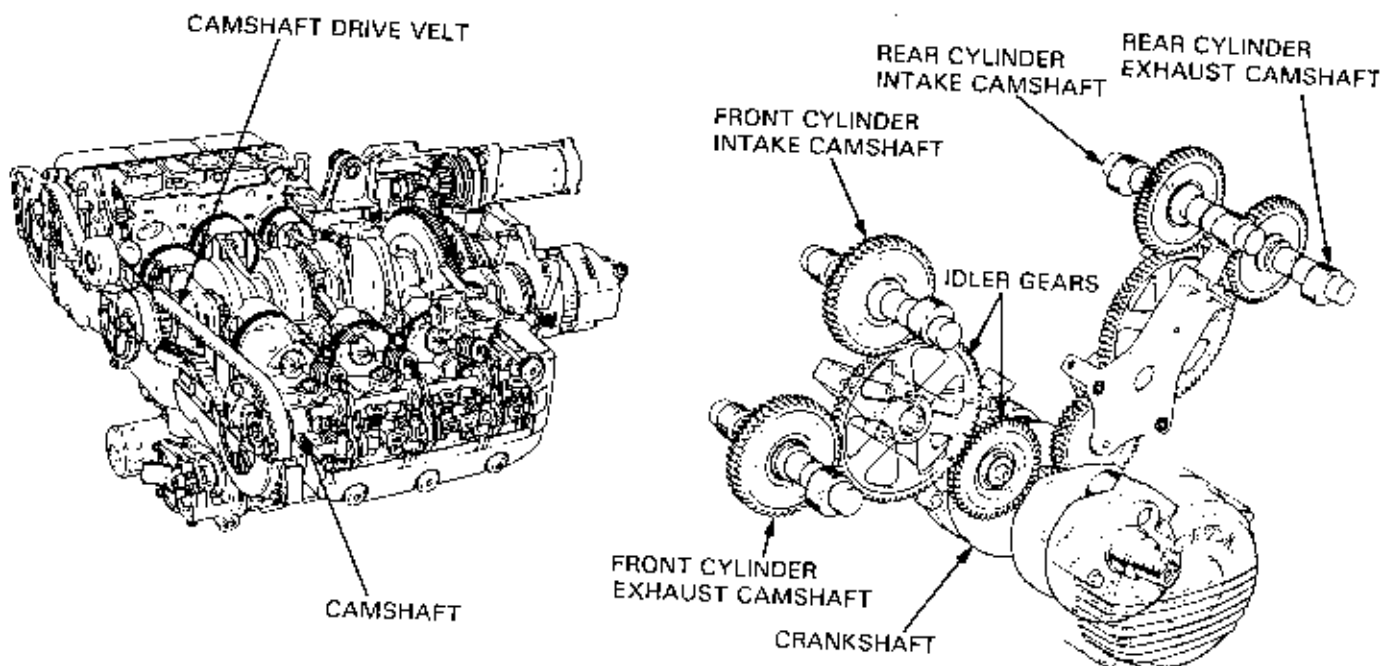

CYLINDER HEAD

VALVE LIFTER MECHANISM/ARRANGEMENT

The current camshaft arrangement in 4-stroke engines can be divided into Single Over Head Camshaft (SOHC) and Double Over Head Camshaft (DOHC) configurations.

The SOHC follows the basic design of 4-stroke engines, operating IN and EX valves through rocker arms with one camshaft. Compared to the DOHC, the SOHC type is less expensive to manufacture and is easier to maintain due to the reduced number of parts. However, "valve jump" (where the valve cannot accurately follow the cam when the engine rotates at high speed) can occur, causing the valve to contact the piston, and causing severe engine damage. To decrease valve mass and reduce the possibility of engine damage during high engine speeds, 4-stroke engines requiring high power generally use the DOHC design in which the valves are operated directly with two separate camshafts for IN and EX valves.

The DOHC configuration can be of two designs: a type pressing the valve bucket directly, or a type lifting the valve through the use of a rocker arm. For the former, a shim is provided in the bucket for valve clearance adjustment. The valve clearance is adjusted by replacing the shim. The shim is usually provided between the bucket and the cam lobe.

Some types have a small shim inserted between the under side of the bucket and the valve stem, allowing less valve actuating mechanism weight.

Some DOHC types are also equipped with rocker arms, allowing easier adjustment of valve clearance.

The DOHC has a further advantage when combined with the 4-valves per cylinder engine type. A larger valve area can be provided in the 4-valve type in comparison to that of the 2-valve type, enabling a greater intake volume of air/fuel mixture and a smoother exhaust. Valve weight is also less, consequently reducing the likelihood of valve jump associated with high engine speeds. Furthermore, with a 4-valve type the spark plug can be placed at the center of the combustion chamber, allowing an easy flame propagation balance during combustion.

EXAMPLE OF SOHC-4 VALVE SYSTEM

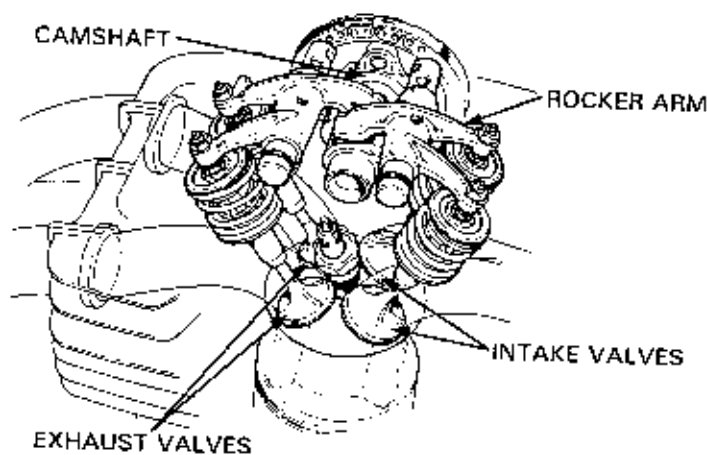

EXAMPLE OF DOHC WITH VALVE BUCKET TYPE

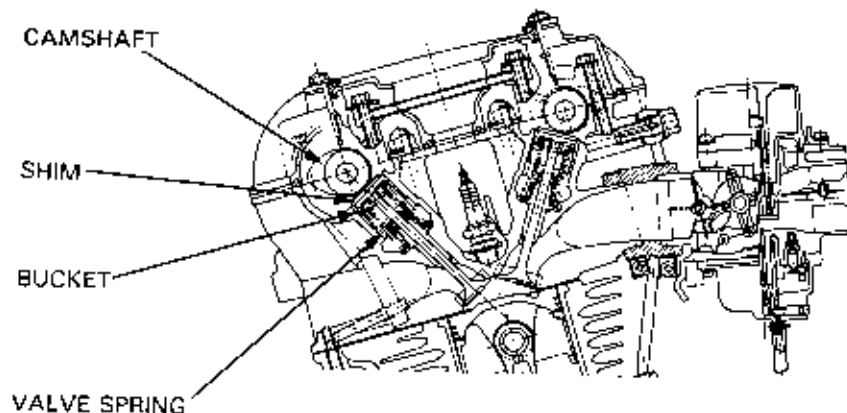

CAMSHAFT

CAMSHAFT INSPECTION

Inspect the cam lobes and replace cams that are worn, scored or scratched.

NOTE

- Inspect the rocker arm if the cam lobe is worn or damaged.

Inspect the journal surfaces. Replace the camshaft if any of the working surfaces are worn, scored or scratched.

NOTE

- Inspect the oil passages and camshaft holders for wear or damage if the journal surface is worn or damaged.

Measure the journal O.D. and cam height. Replace any camshaft if its measurements are beyond the service limits.

Check camshaft runout with a dial indicator. Support both ends of the camshaft with V-blocks.

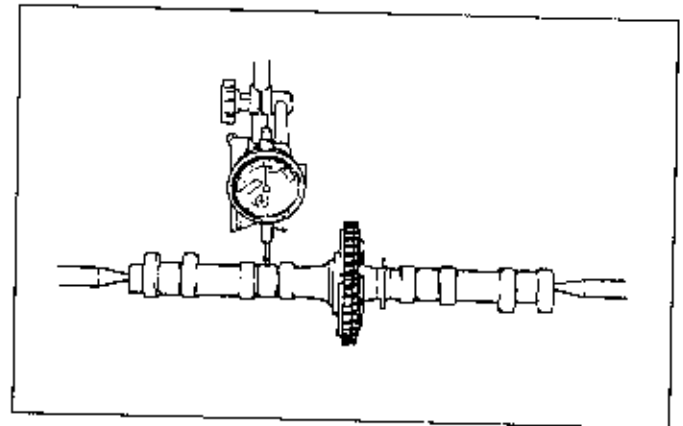
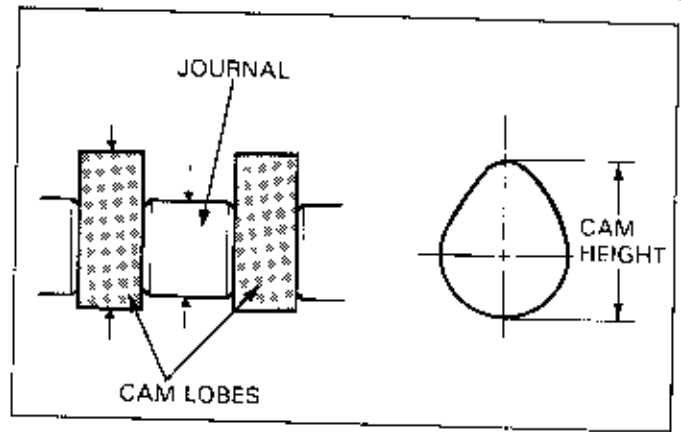

CAMSHAFT BEARING INSPECTION

Check that the bearing inner race fits the camshaft tightly without play.

Turn the outer race and check that the bearing turns smoothly and quietly.

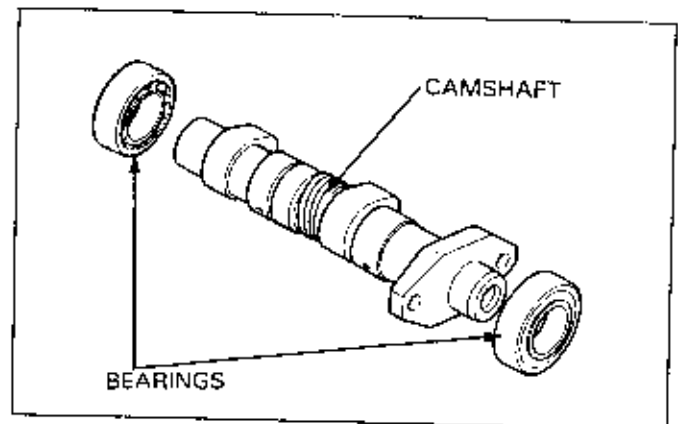

CAMSHAFT OIL CLEARANCE INSPECTION

The oil clearance is the difference between the camshaft holder I.D. and the journal O.D.

Measure the camshaft holder journal I.D. with a dial indicator. Subtract the camshaft journal O.D. from the camshaft holder journal I.D. to obtain the oil clearance.

When the service limits are exceeded, replace the camshaft and recheck the oil clearance.

Replace the cylinder head and camshaft holders if the clearance still exceeds service limits.

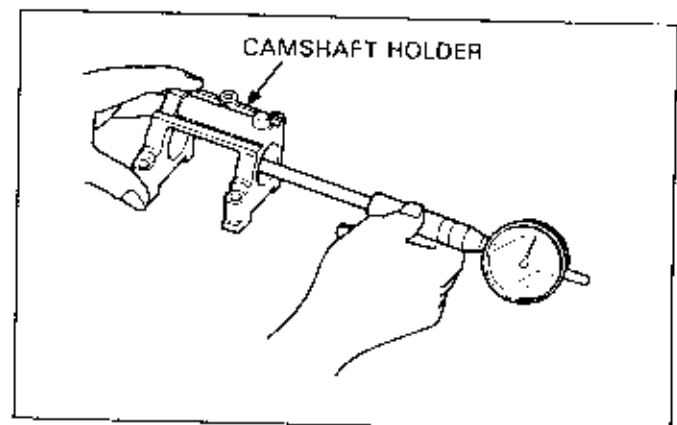

CYLINDER HEAD

If a dial indicator cannot be used, measure the oil clearances using plastigauge:

Clean off any oil from the camshaft journals.

Put the camshaft in the cylinder head and place a strip of plastigauge on top of each camshaft journal.

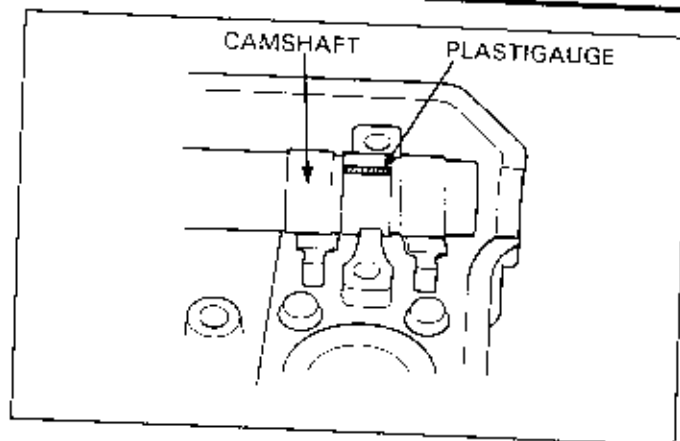

Install the camshaft holders and tighten the mounting bolts to the specified torque. (Refer to the Model Specific manual for the correct torque specification)

NOTE

- Do not rotate the camshaft during inspection.

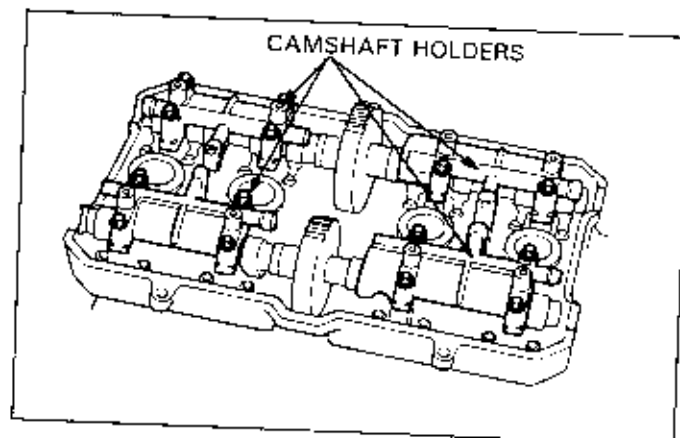

Remove the camshaft holders and measure the width of each plastigauge. The widest thickness determines the oil clearance.

When the service limits are exceeded, replace the camshaft and recheck the oil clearance.

Replace the cylinder head and camshaft holders if the clearance still exceeds service limits.

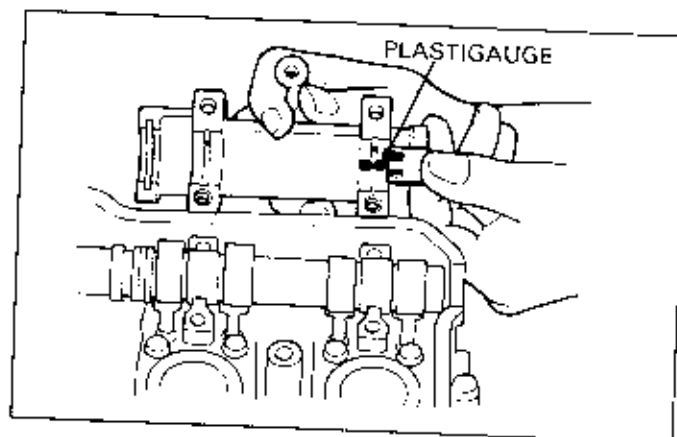

ROCKER ARM, ROCKER ARM SHAFT

Inspect the sliding surface of the rocker arms for wear or damage where they contact the camshaft, or for clogged oil holes.

Measure the I.D. of each rocker arm.

Measure each rocker arm and shaft O.D.

Inspect the shaft for wear or damage and calculate the shaft to rocker arm clearance.

Replace the rocker arm and/or shaft if the measurements exceed the service limits.

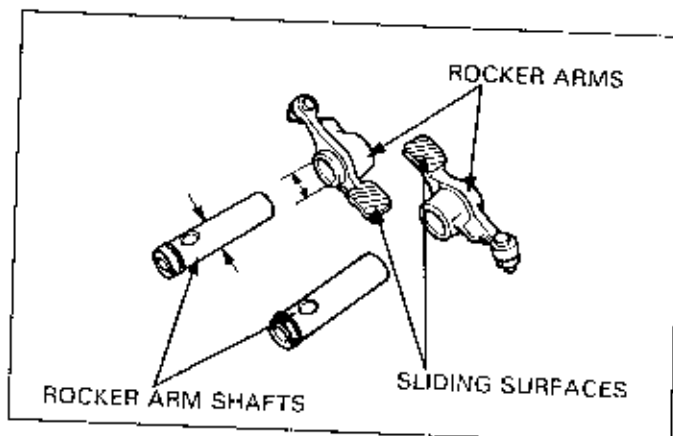

CYLINDER HEAD INSPECTION

SOLVENT TEST

Remove the cylinder head.

Be sure that the valve is installed on the cylinder head and place the cylinder head with the intake port toward up. Pour the kerosine from the intake port into the cylinder head. Wait for a few minutes, then check the combustion chamber side valve area for kerosine leakage.

With the exhaust port toward up, pour the kerosine from the exhaust port into the cylinder head, wait for a few minutes, and check for kerosine leakage.

If kerosine leaks from around the valve, it indicates faulty sealing of the valve seat. Remove the valve from the cylinder head and check the following.

- Valve seat for damage (page 9-11)
- Valve seat contact face (page 9-11)
- Valve stem for bend or damage (page 9-8)

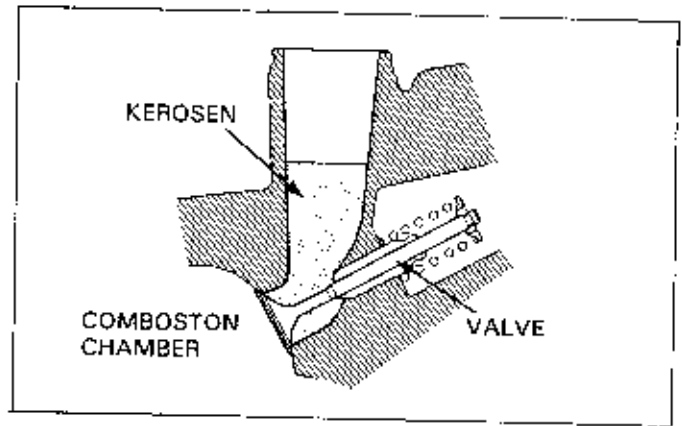

WARPAGE INSPECTION

Remove carbon deposits from the combustion chamber and clean off the head gasket surfaces.

NOTE

- Gaskets will come off easier if soaked in high flash-point cleaning solvent.

CAUTION

- Avoid damaging the gasket and valve seat surfaces.

Check the spark plug hole and valve areas for cracks.

Check the cylinder head for warpage with a straight edge and feeler gauge.

Repair or replace the cylinder head if warpage exceeds the service limit. (Refer to the Model Specific manual)

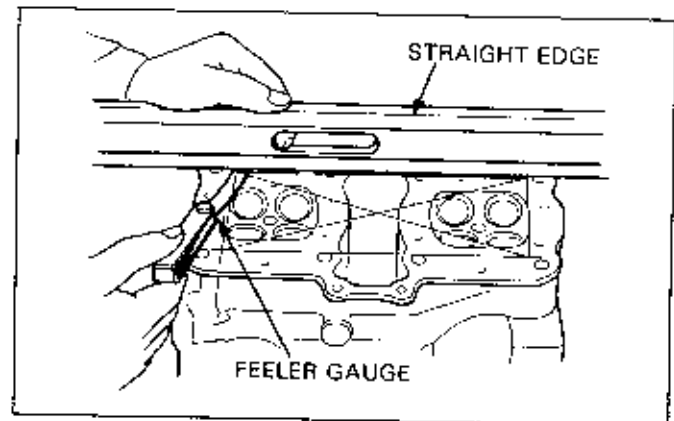

CYLINDER HEAD

CYLINDER HEAD DISASSEMBLY

Remove the cylinder head according to the Model Specific manual.

Remove the valve cotters with the valve spring compressor.

TOOL:

VALVE SPRING COMPRESSOR 07757-0010000 and
ATTACHMENT
(as necessary)

CAUTION

- Compressing the valve springs more than necessary will cause loss of valve spring tension.

Remove the valve spring compressor, then remove the retainers, valve springs and valves.

NOTE

- Mark the valves so they can be replaced in their original positions for installation later.

Remove and discard the stem seal if necessary.

NOTE

- Do not reuse the removed stem seal.

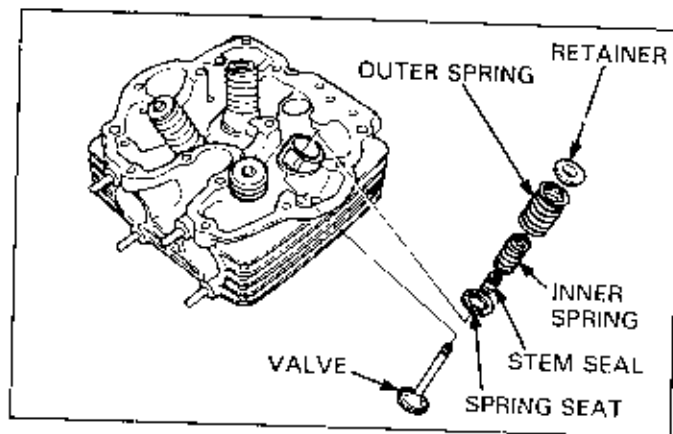
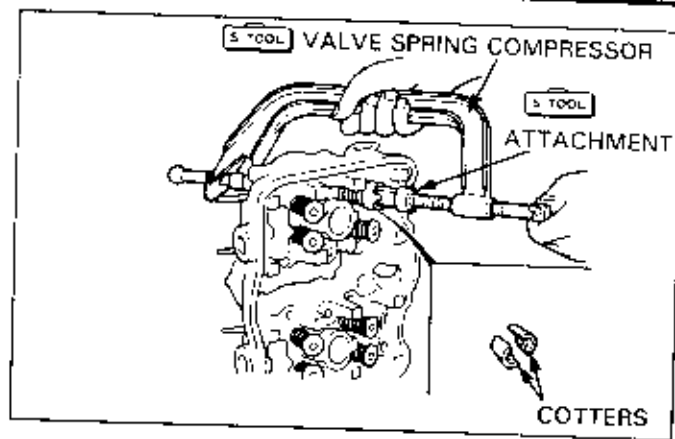

VALVE SPRINGS

Measure the free length of the inner and outer valve springs.

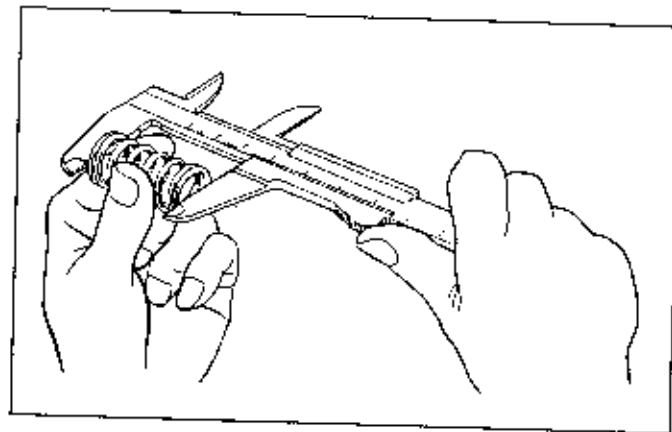

VALVES

Inspect each valve for bending, burning, scratches or abnormal wear.

Insert the valves in their original positions in the cylinder head. Check that each valve moves up and down smoothly, without binding.

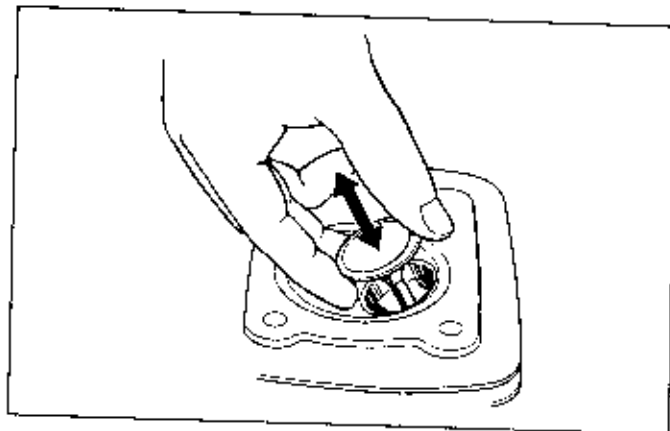

Measure and record the valve stem O.D. in three places along the valve guide sliding area.

Replace the valve with a new one if the service limit is exceeded.

VALVE GUIDES

INSPECTION

Insert the valve guide reamer from the combustion chamber side and ream the guide to remove any carbon build-up before measuring the guide.

NOTE

- Take care not to tilt or lean the reamer in the guide while reaming. Otherwise, the valve is installed slanted, that causes oil leaks from the stem seal and improper valve seat contact and results in the valve seat refacing not able to be performed.
- Rotate the reamer clockwise, never counterclockwise when inserting and removing.

Measure and record each valve guide I.D. using a ball gauge or inside micrometer.

STEM-TO-GUIDE CLEARANCE

When using a dial indicator:

Measure the guide-to-stem clearance with a dial indicator while rocking the stem in the direction of normal thrust (wobble method).

REPLACEMENT

NOTE

- Refinish the valve seats whenever the valve guides are replaced to prevent uneven seating.

Flanged Guides:

Chill the valve guides in the freezer section of a refrigerator for about an hour.

Heat the cylinder head to 130°C–140°C (275°F–290°F). Do not heat the cylinder head beyond 150°C (300°F). Use temperature indicator sticks, available from welding supply stores, to be sure the cylinder head is heated to the proper temperature.

CAUTION

- Using a torch to heat the cylinder head may cause warping.

WARNING

- Wear insulated gloves to avoid burns when handling the heated cylinder head.

Support the cylinder head and drive the old guides out of the combustion chamber side of the cylinder head.

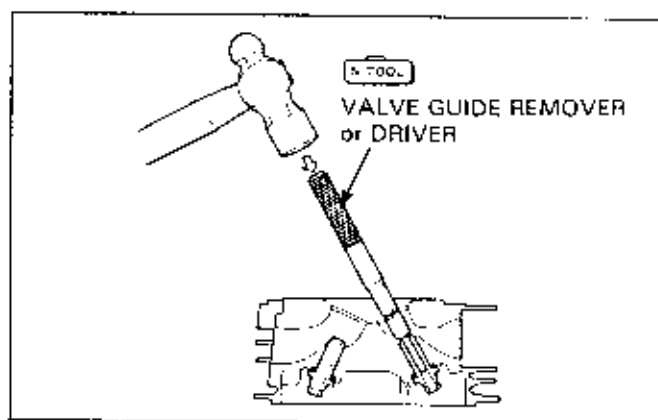
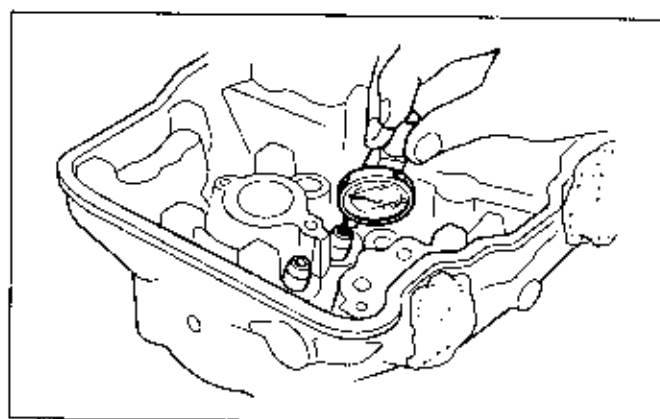
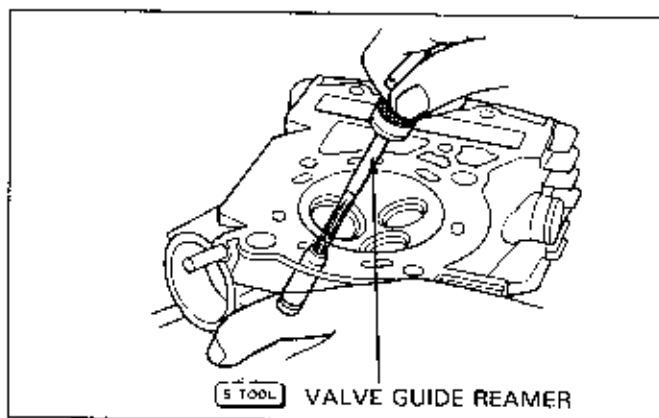
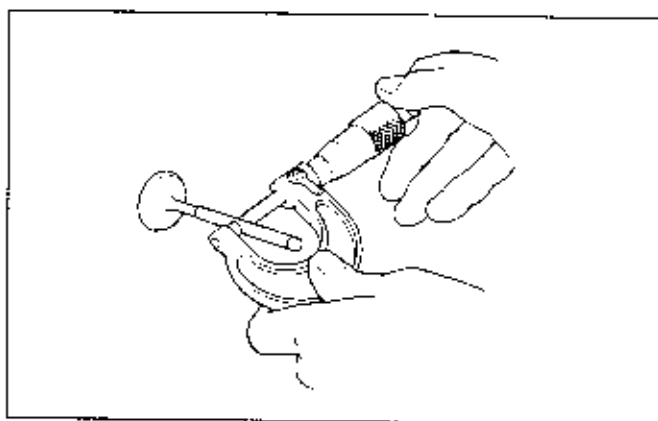

CYLINDER HEAD

CAUTION

- Avoid damaging the head when driving the valve guide out.

Apply oil to a new O-ring and install it onto a new valve guide. Drive the new guide in from the camshaft side of the cylinder head while the cylinder head is still heated.

Let the cylinder head cool to room temperature, then ream the new valve guides.

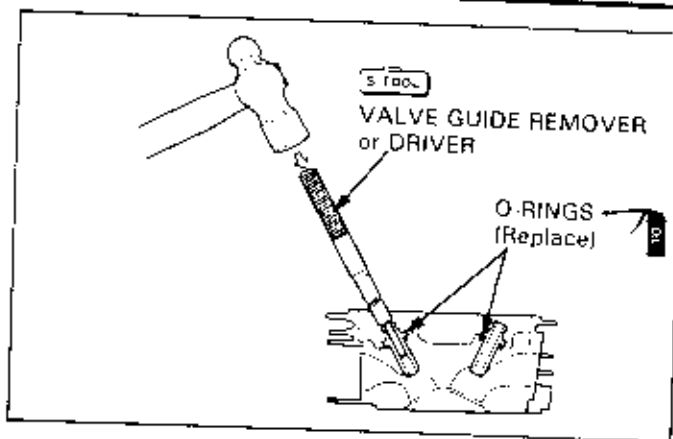

Flangeless Type Guides:

Measure and record the exposed height of the valve guide using a pair of vernier calipers.

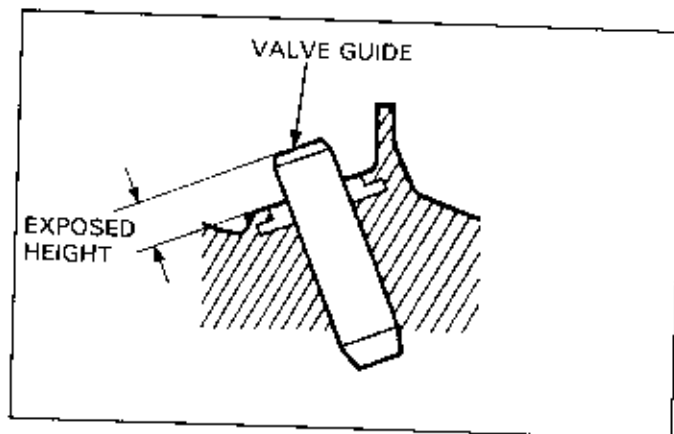

Chill the valve guides in the freezer section of a refrigerator for about an hour.

Heat the cylinder head to 130°C–140°C (275°F–290°F). Do not heat the cylinder head beyond 150°C (300°F). Use temperature indicator sticks, available from welding supply stores, to be sure the cylinder head is heated to the proper temperature.

CAUTION

- Using a torch to heat the cylinder head may cause warping.

WARNING

- To avoid burns, wear insulated gloves when handling the heated cylinder head.

Support the cylinder head and drive the old guides out of the combustion chamber side of the cylinder.

CAUTION

- Avoid damaging the head when driving the valve guide out.

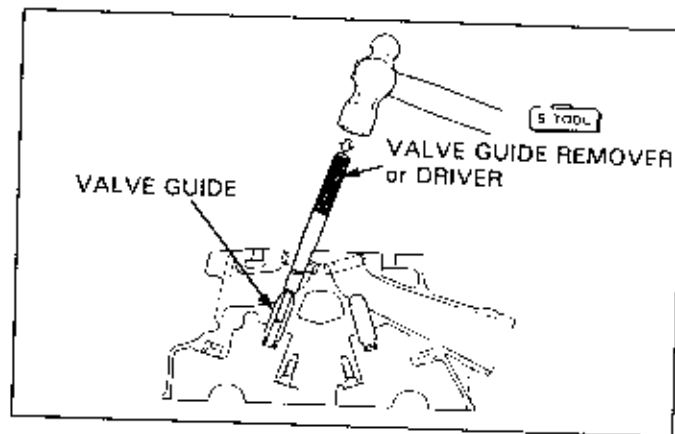

While the cylinder head is still heated, drive a new valve guide in from valve spring side until the exposed height is the same as was measured for the old guide.

Let the cylinder head cool to room temperature and ream the new valve guide.

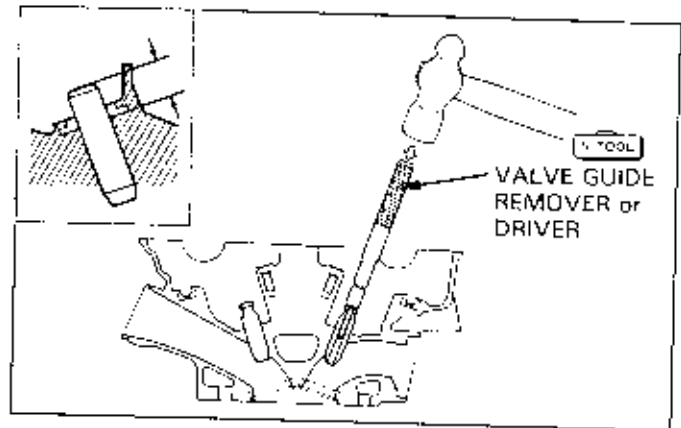

VALVE GUIDE REAMING

When reaming new valve guides, insert the valve guide reamer from the combustion chamber side.

NOTE

- Take care not to tilt or lean the reamer in the guide while reaming. Otherwise, the valve is installed slanted, that causes oil leaks from the stem seal and improper valve seat contact and results in the valve seat refacing not able to be performed.
- Use cutting oil on the reamer during this operation.
- Rotate the reamer clockwise, never counterclockwise when inserting and removing.

Reface the valve seats and clean the cylinder head thoroughly to remove any metal particles.

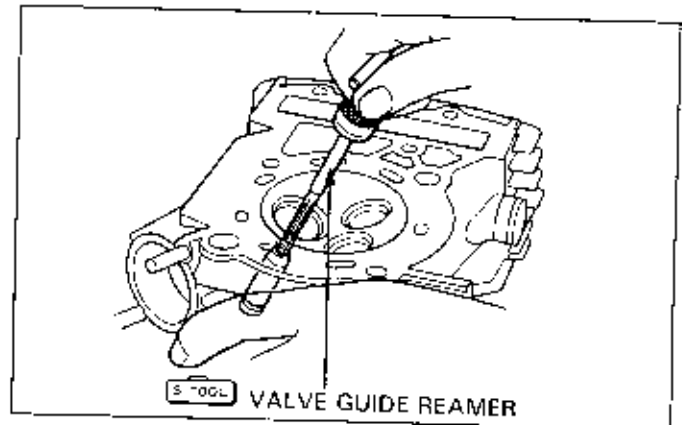

VALVE SEATS

INSPECTION

Clean all intake and exhaust valves thoroughly to remove carbon deposits.

Apply a light coating of Prussian Blue to each valve face.

NOTE

- Tap the valve against the valve seat several times with your finger, without rotating the valve, to check for proper valve seat contact.

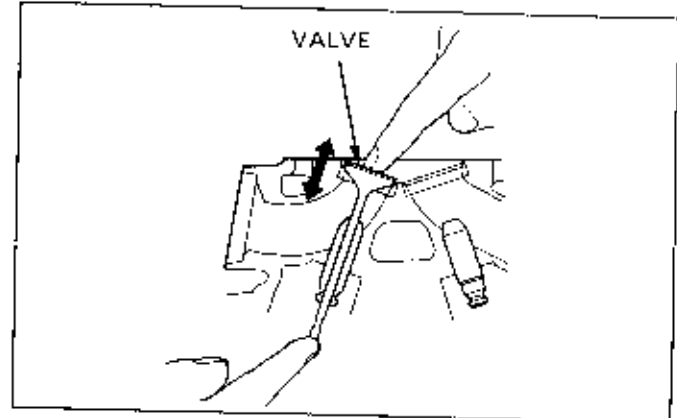

Remove the valve and inspect the valve seat face. The valve seat contact should be within the specified width and evenly all around the circumference. If the valve seat width is not within specification, reface the valve seat (page 9-12).

NOTE

- Most valve faces and stem tips are coated with a thin layer of stellite so they cannot be ground. If a valve face or stem tip is rough, worn unevenly, or contacts the seat improperly, the valve must be replaced.

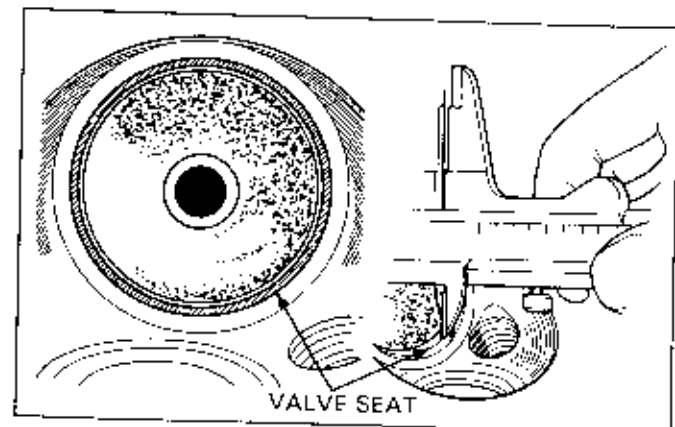

CYLINDER HEAD

Inspect the valve seat face for:

- Uneven seat width:
 - Bent or collapsed valve stem;
Replace the valve and reface the valve seat.
- Damaged face:
 - Replace the valve and reface the valve seat.

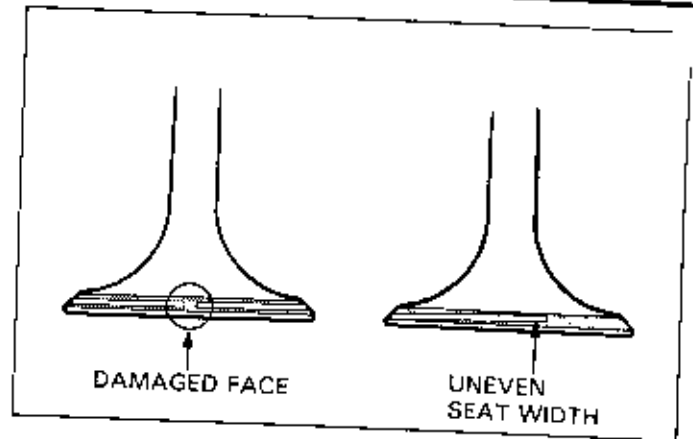

- Contact area (too high or too low area).
 - Reface the valve seat.

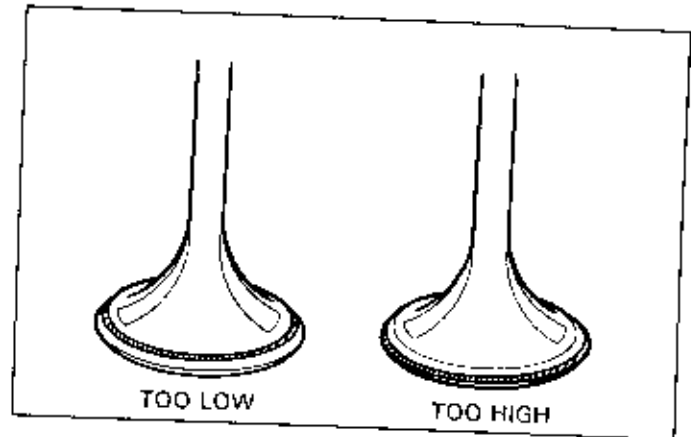

VALVE SEAT REFACING

NOTE

- Follow the refacer manufacturer's operating instructions.
- Reface the valve seat whenever the valve guide has been replaced.
- Be careful not to grind the seat more than necessary.

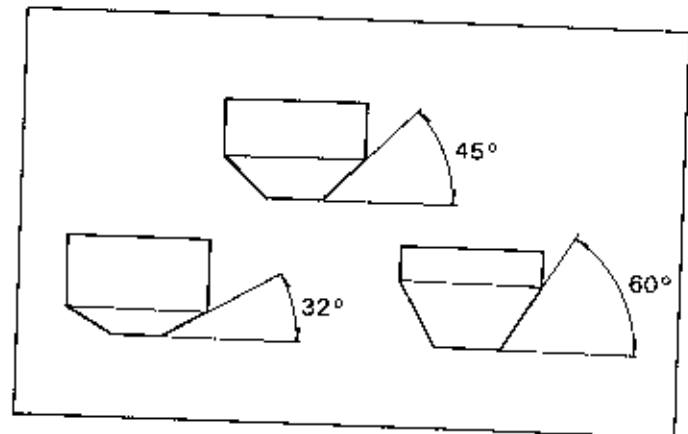

If the contact area is too high on the valve, the seat must be lowered using a 32 degree flat cutter.

If the contact area is too low on the valve, the seat must be raised using a 60 degree inner cutter. Refinish the seat to specifications, using a 45 degree finish cutter.

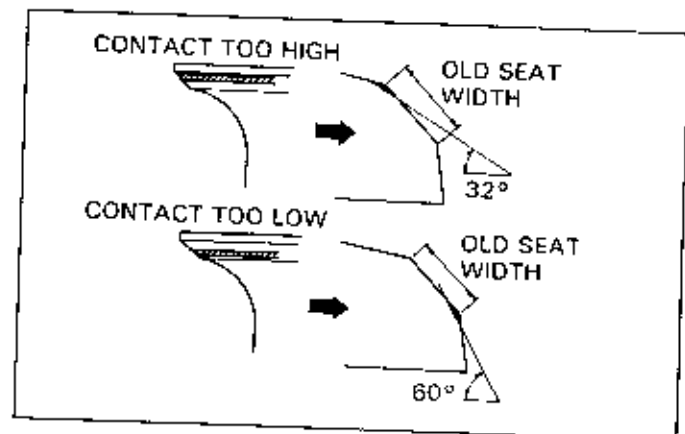

Using a 45 degree cutter, remove any roughness or irregularities from the seat.

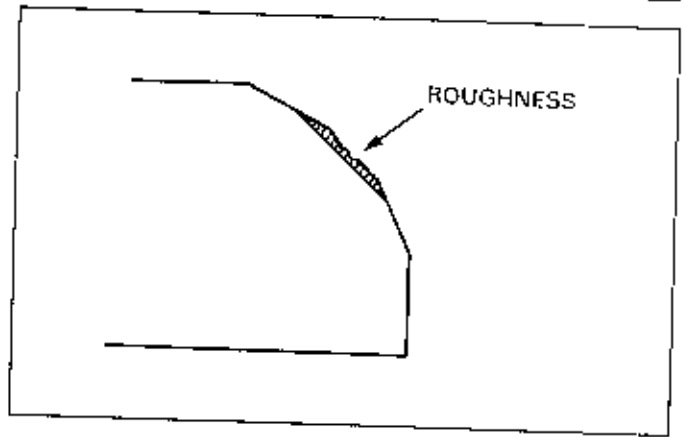

Using a 32 degree cutter, remove 1/4 of the existing valve seat material.

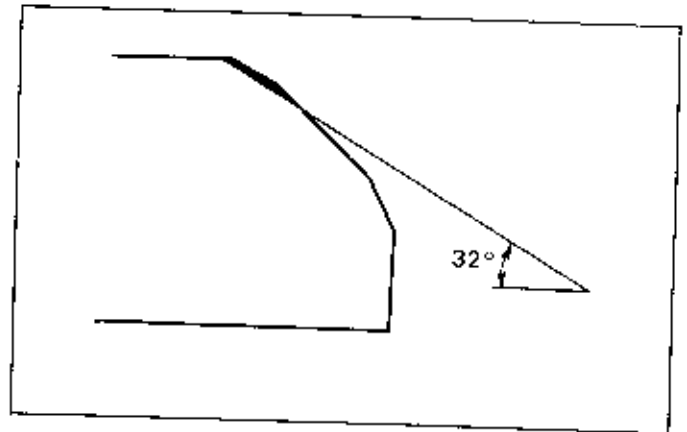

Using a 60 degree cutter, remove the bottom 1/4 of the old seat.

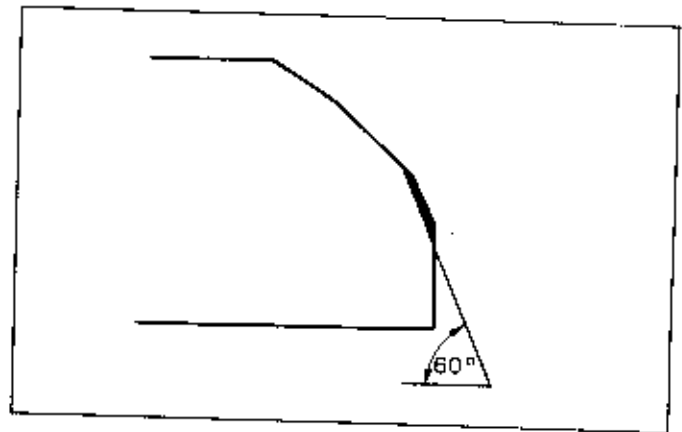

Using a 45 degree cutter, cut the seat to the proper width.

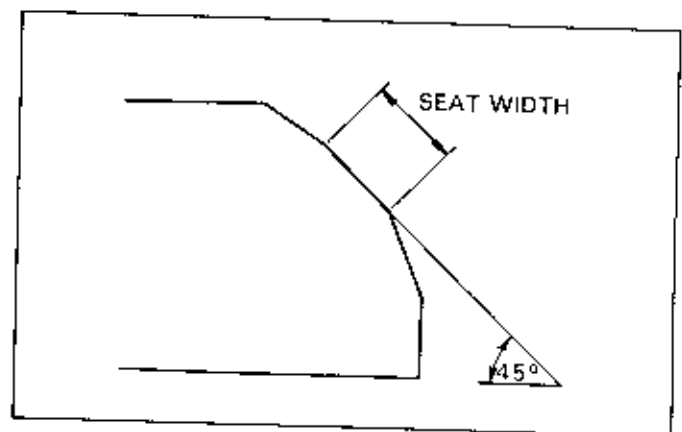

CYLINDER HEAD

After cutting the seat, apply lapping compound to the valve face, and lap the valve using light pressure.

CAUTION

- Excessive lapping pressure may deform or damage the seat.
- Change the angle of lapping tool frequently to prevent uneven seat wear.
- Lapping compound can cause damage if it enters between the valve stem and guide.

After lapping, wash any residual compound off the cylinder head and valve.

NOTE

- Lapping has no effect on long-term durability or performance. It only ensures that the valve and valve seat will pass a solvent test.

Recheck the seat contact after lapping.

CYLINDER HEAD ASSEMBLY

Install new stem seals.

NOTE

- Replace the stem seals with new ones whenever a stem seal is removed.

Lubricate each valve stem with molybdenum disulfide grease and insert the valve into the valve guide.

CAUTION

- Turning a valve too fast can damage the stem seals.

Install the spring seats, valve springs and retainers.

NOTE

- For valve spring with varying pitch, install the valve springs with the narrow pitch end facing down.

Compress the valve springs with the valve spring compressor and install the valve cotters.

CAUTION

- Compressing the valve spring more than necessary when installing the valve cotters may cause loss of valve spring tension.

NOTE

- To ease installation of the cotters, grease them first.

Tap the valve stems gently with a soft hammer to firmly seat the cotters.

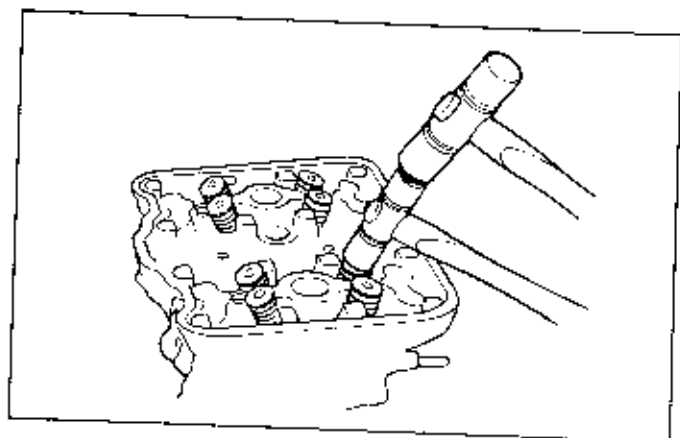
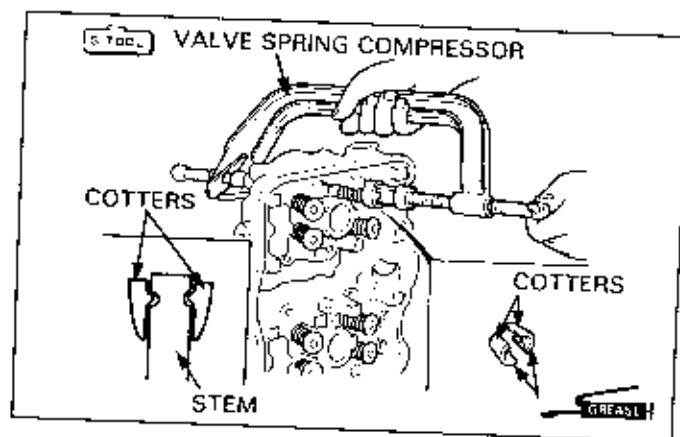
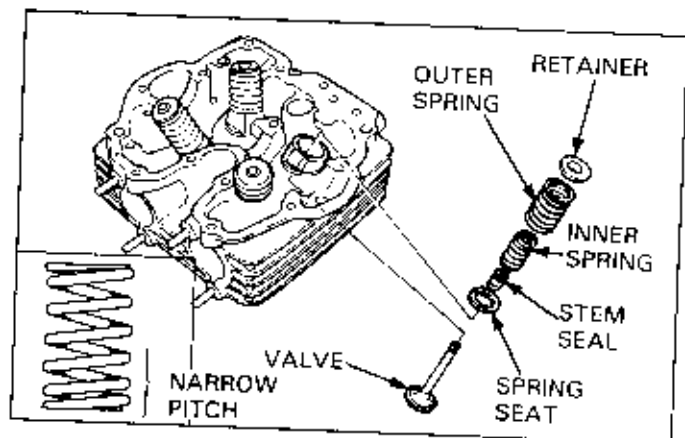
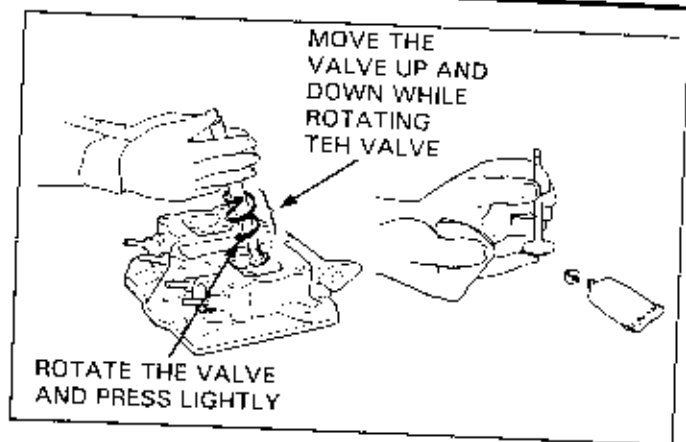

Clean any gasket material from the cylinder mating surface.
Reface the mating surface using oil stone, if necessary.

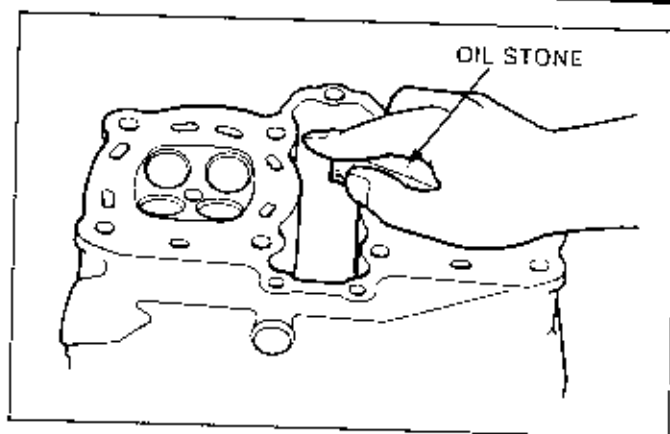

INITIAL CAMSHAFT LUBRICATION

Apply molybdenum disulfide grease to the camshaft journal surfaces in the cylinder head.

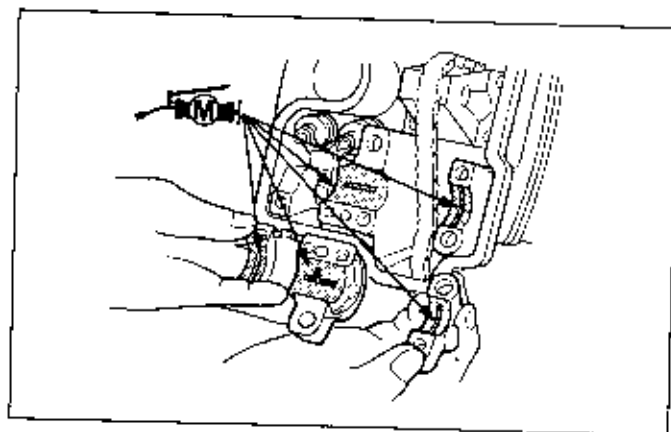

Fill the oil pockets in the head with the recommended oil.

